

Stafsjö®
SINCE 1666

Knife gate valve MV

Uni-directional knife gate valve for on/off or control of liquids and dry media

Size range:
DN 50 - DN 1800 (2" - 72")

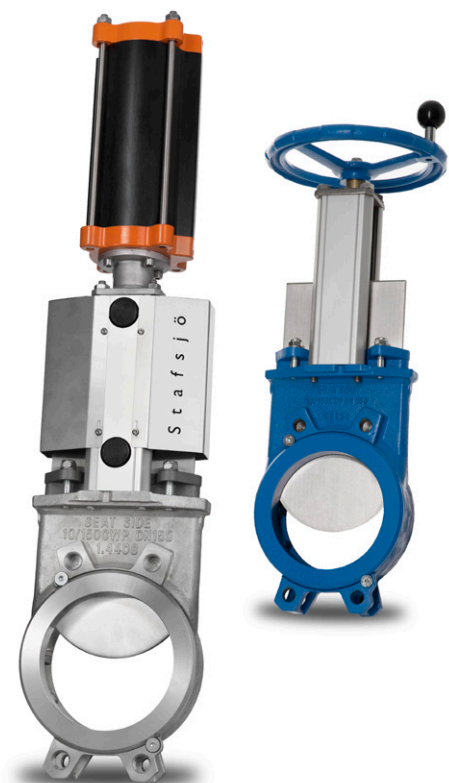

About MV

Stafsjö's knife gate valve MV can be used within a wide range of applications on both dry media and liquids such as pulp stock up to 7% consistency, sludge, slurry, biomass, water, ash, granulate and different kinds of waste.

The MV valve is modular designed and it can easily be customized in materials, with actuators and related automation accessories to different process conditions. As standard it is available in a stainless steel or a nodular iron version, but it can also be supplied in a range of high alloy materials such as Duplex and 254 SMO. Staffsjö's retainer ring system offers great flexibility and several seat material options. Up to DN 800 the MV has a single piece valve body and from DN 900 it features a rigid two-piece version.

Staffsjö's gland box system with TwinPack braids ensures that no media reaches the surrounding environment. It can also be reinforced with a box bottom scraper or with a double gland for the most demanding applications.

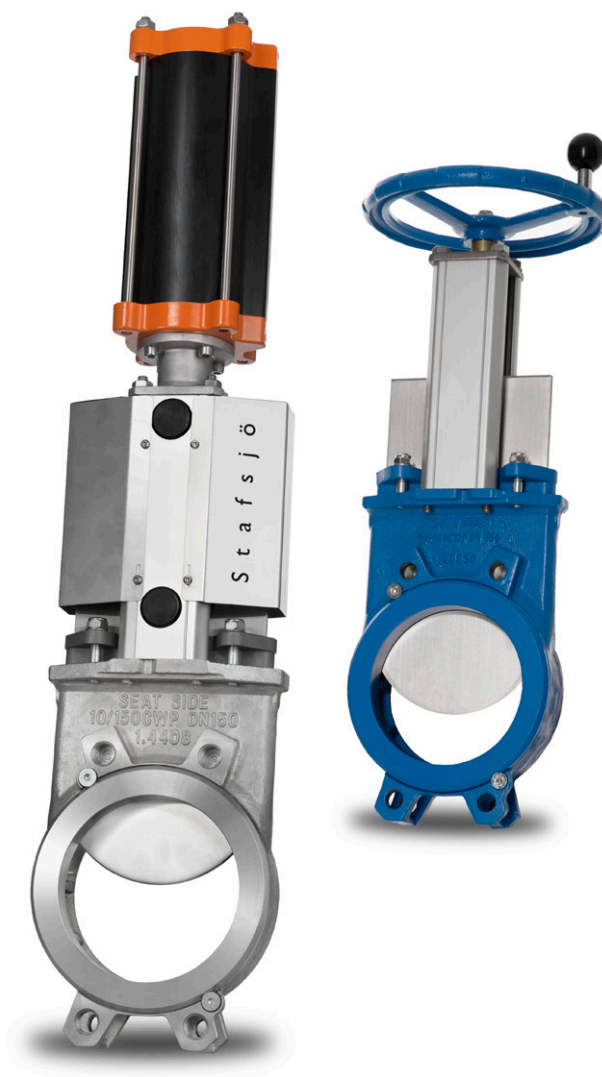

Reliable zero leakage shut-off

Ideal internal clearances lowers the friction and make it easy for the beveled edge gate (1) to cut through both liquids and dry media. When the gate reaches its final stage of closure it stops on the cast and precision machined body cams (2). The gate is pushed against the seat (3) and provide a uni-directional tight shut-off. Several smaller valve sizes are also capable of sealing to some reverse flow as standard due to the machined body cams.

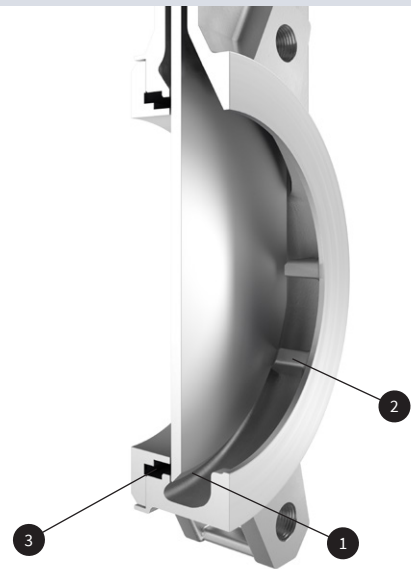

Quick and easy maintenance

The retainer ring (4) hold the seat (5) in exact correct position as the gate strokes. It is mechanically locked and it can easily be removed for seat change. Both the retainer ring and seat is available in several different materials which makes it easy to customize MV to different process conditions.

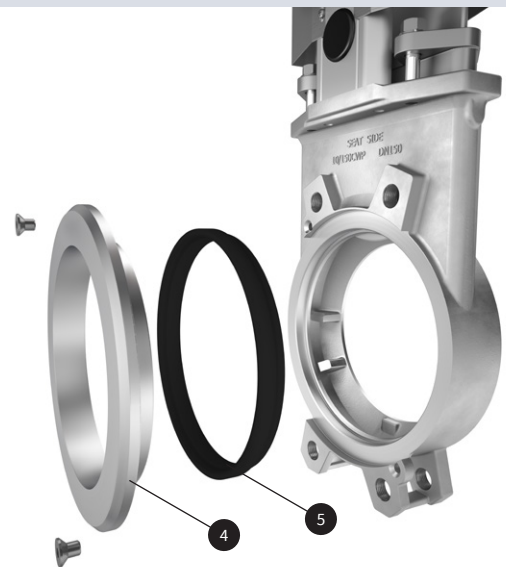

High strength top works

Smooth cycling and a tight shut-off independent of valve position is achieved by the high strength top works that provide an essential alignment for the gate. It utilizes stainless steel tie rods (6) encapsulated inside the structural beams (7). Stafsjö assemble stainless steel gate guards (8) as standard on all automated valves.

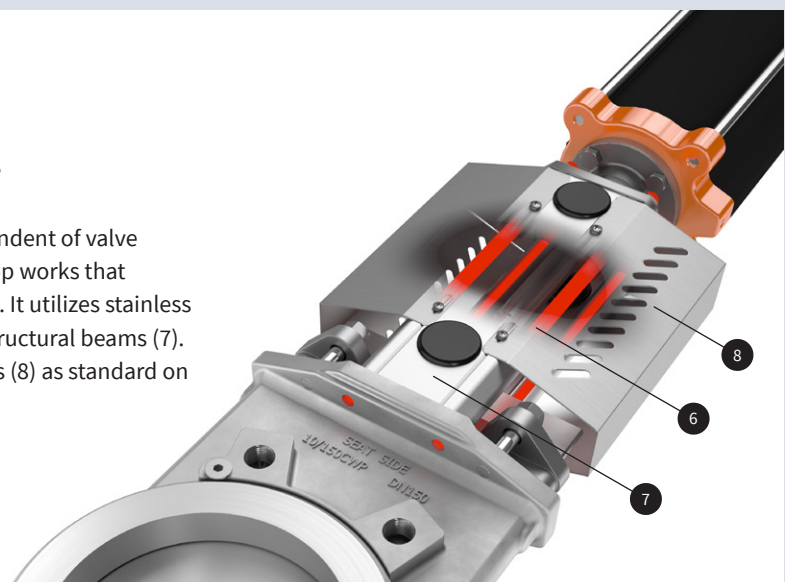

Pressure class

Max working pressure at 20 °C		Max differential pressure at 20 °C		Max differential pressure in reverse pressure direction at 20 °C		
DN	bar	DN	bar	DN	bar	bar
50 - 125	16	50 - 125	16	50 - 200	3,5 ³⁾	3,5 ⁴⁾
150 - 300	10	150 - 300	10	250	3,0 ³⁾	3,0 ⁴⁾
350 - 600	6	350 - 600	6	300 - 450	On request	3,0 ⁴⁾
700 - 1000	4 ¹⁾	700 - 1000	4 ¹⁾	500 - 1800	On request	
1200 - 1800	4 ²⁾	1200 - 1800	2 or 4 ²⁾			

MV configurations

Standard in stainless steel

Sizes: DN 50 - DN 1800

Valve body: Stainless steel EN 1.4408

Retainer ring: Stainless steel EN 1.4408

Gate: Stainless steel EN 1.4404, AISI 316L

Box packing: TwinPack

Top works: Stainless steel tie rods encapsulated in aluminum beams up to DN 1000 and stainless steel beams on larger ones including stainless steel gate guards on automated valves

Standard in nodular iron

Sizes: DN 50 - DN 800

Valve body: Nodular iron EN 5.3105, EN-JS1050, GGG50

Retainer ring: Nodular iron EN 5,3105, EN-JS1050, GGG50, ≥ DN 600 Stainless steel EN 1.4408

Gate: Stainless steel EN 1.4301, AISI 304

Box packing: TwinPack

Top works: Stainless steel tie rods encapsulated in aluminum beams including stainless steel gate guards on automated valve

Options

Valve body

Stainless steel EN 1.4408

Nodular iron EN 5.3105, EN-JS1050, GGG50

Duplex stainless steel EN 1.4470

Equivalent material to 254 SMO stainless steel

Retainer rings

Stainless steel EN 1.4408

Nodular iron EN 5.3105, EN-JS1050, GGG50

Duplex stainless steel EN 1.4470

Equivalent material to 254 SMO stainless steel

Polyurethane

Gate material and surface treatments

Stainless steel EN 1.4301, AISI 304

Stainless steel EN 1.4404, AISI 316L

Duplex stainless steel EN 1.4462, S32205

254 SMO stainless steel or equivalent

Hard chromed surface

Extra polished surface (max Ra 0,8)

Seats

PTFE with o-ring in EPDM, FPM/FKM or NBR

FDA/EC 1935/2004 approved PTFE

EPDM, FPM/FKM, NBR or Polyurethane

Stainless steel metal seat with grafoil tape or o-rings in EPDM, FKM, NBR

Box packings

TwinPack, WhitePack, FDA/EC 1935/2004 approved PTFE or Graphite

Extra scrapers in UHMW-PE, PTFE or brass

Top works

Stainless steel tie rods encapsulated in aluminum beams

Stainless steel pillars⁵⁾ or beams

Actuators

Hand wheel with non-rising stem

Chain wheel

Hand lever⁶⁾

Ratchet wrench

Bevel gear

Double-acting pneumatic cylinders

Single-acting pneumatic cylinders

Electric actuators

Hydraulic actuator

Flange drillings

EN 1092 PN 10

EN 1092 PN 16

ASME/ANSI B16.5 Class 150 and B16.47 Class 150, series A

JIS B 2238 10K

AS 2129 Table D and E

BS 10 Table D

Accessories

Limit switches, solenoid valves, positioners, mechanical lockouts, purge ports, deflection cone, V-port, double gland, reverse flow kits, stem extensions etc. See our accessory data sheet for further information.

1) MV-E DN 800 is also available in a 10 bar version. Contact Stafsjö for further information.

2) Higher pressure class on request. Contact Stafsjö for further information.

3) Only with seat material in EPDM, FPM/FKM or NBR

4) Only with nodular iron valve body and seat material in EPDM, FPM/FKM or NBR

5) Standard on valves supplied with valve body in duplex or equivalent material to 254 SMO stainless steel.

6) Pressures according to design data are not valid for valve equipped with hand lever. Maximum working and differential pressure in preferred direction at 20°C for DN 50 - DN 150: 4 bar.

Design standards

Design, manufacturing, inspection and test

According to pressure equipment directive 2014/68/EU category I and II module A2. The valves are CE marked when it is applicable.

Stafsjö's valves are subject for pressure tests before delivery in opened and closed position with water at 20 °C according to EN 12266-1:2003 rate A. No visually detectable leakage is allowed for duration of the test. Rate A is not applicable on metal seated valves.

On request Stafsjö can provide 2.2 test report and 3.1 inspection certificate according to EN 10204.

Contact Stafsjö for further information on ATEX approved solutions.

Face-to-face dimensions

Stafsjö manufacturing standard. Option in MSS-SP81.

Corrosion protection

Painted valve parts fulfill in applicable areas corrosion protection against environment according EN ISO 12944, corrosivity category C3. Other paint systems can be offered on request.

Service temperature

Information to determine minimum and maximum temperature for the knife gate valve is available on stafsjo.com/support/temperatures/.

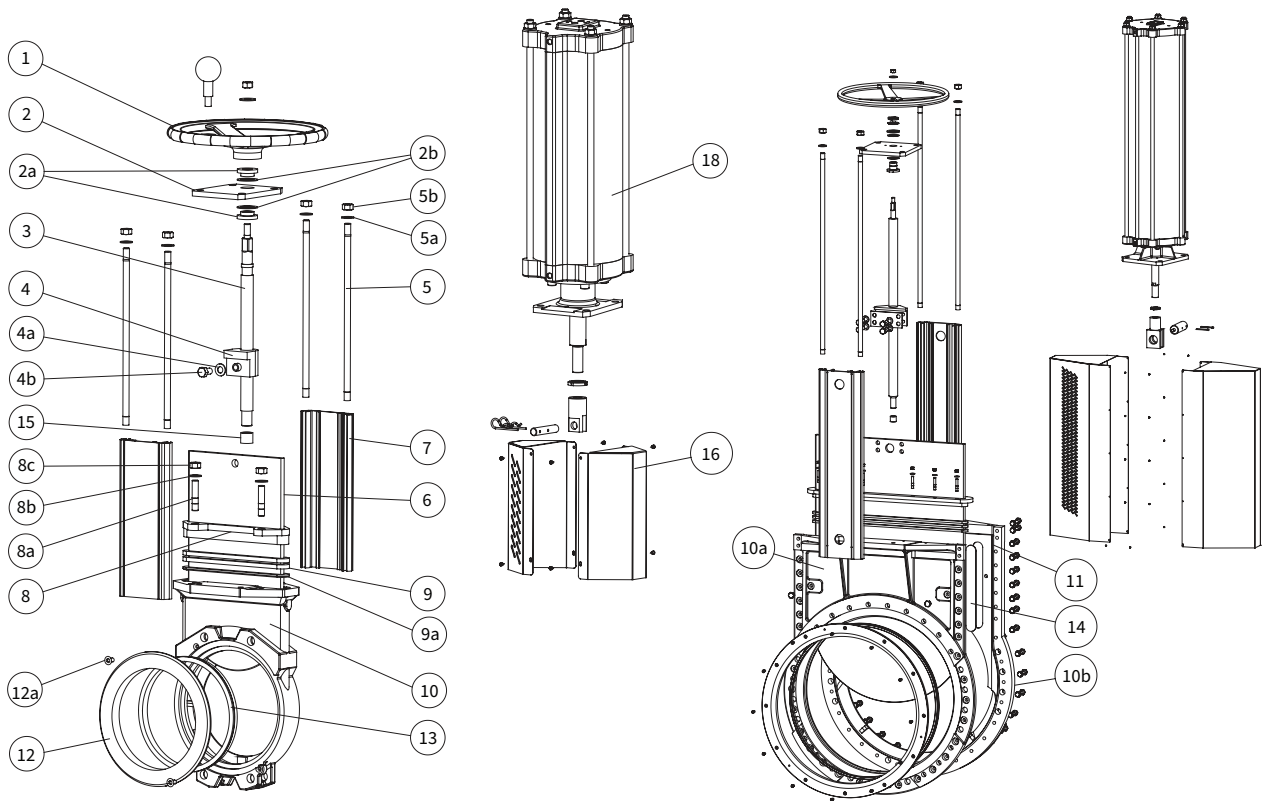

Part list

Pos.	Part	Material
1	Hand wheel	Coated cast iron Ø 200 - Ø 315 EN-JL1040, GG25, ≥ Ø 400 EN-JL1030, GG20
2	Yoke	Stainless steel EN 1.4301
2a	Bearing	Brass
2b	Slide washer	POM
3	Stem	Stainless steel EN 1.4016, EN 1.4305
4	Stem nut	Brass
4a	Washer	Stainless steel A2
4b	Screw	Stainless steel A2
5	Tie rod	Stainless steel EN 1.4301
5a	Washer	Stainless steel A2
5b	Nut	Stainless steel A2
6	Gate	See options on page 4
7	Beam	Anodized aluminum
8	Gland	Stainless steel EN 1.4408 Coated steel on MV-L < DN 300

Pos.	Part	Material
8a	Stud bolt	Stainless steel A2
8b	Washer	Stainless steel A2
8c	Nut	Stainless steel A2
9 ¹⁾	Box packing	See options on page 4
9a ¹⁾	Box bottom scraper	DN 500 - DN 800: PEHD
10/a/b	Valve body	See options on page 4
11	Body gasket	FPM/FKM
12	Retainer ring	See options on page 4
12a	Locking screw	Stainless steel A2
13 ¹⁾	Seat	See options on page 4
14	Guiding pads	≥ DN 400 PEHD, POM-C or PTFE
15	Bushing	Oil-bronze
16	Gate guards	Stainless steel EN 1.4301
18	Pneumatic cylinder	See separate data sheet

1) Recommended spare part

One piece valve body: DN 50 - DN 800

Two piece valve body: DN 900 - DN 1800

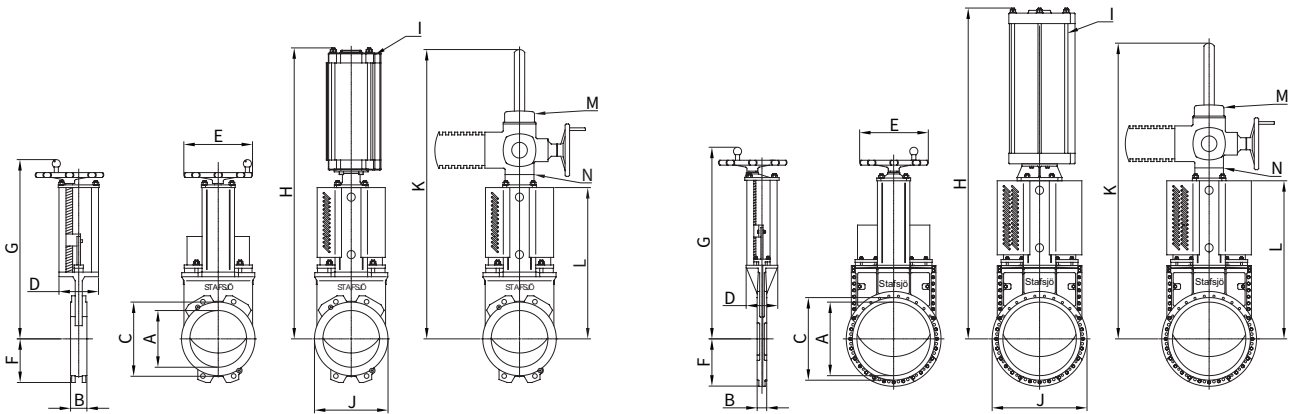

Main dimensions

DN	A	B	C	D	E	F	G	H	I ¹⁾	J	K	L	M ²⁾	N ³⁾	kg ⁴⁾
50	52	41	91	80	200	56	360	505	SC100	116	630	230	SA07.2	F10 A	7
65	64	41	107	80	200	65	380	525	SC100	130	650	250	SA07.2	F10 A	7
80	79	51	124	80	200	88	405	550	SC100	135/170 ⁵⁾	675	275	SA07.2	F10 A	8
100	103	51	154	80	200	102	453	623	SC100	155	723	323	SA07.2	F10 A	10
125	128	56	179	80	250	116	495	690	SC100	178	765	365	SA07.2	F10 A	13
150	153	60	204	80	250	130	550	770	SC100	205	820	420	SA07.2	F10 A	15
200	202	60	267	145	315	160	694	1011	SC160	268	1115	555	SA07.6	F10 A	31
250	250	69	320	145	315	192	779	1151	SC160	320	1250	640	SA07.6	F10 A	40
300	302	78	374	145	315	230	879	1301	SC160	375	1400	740	SA10.2	F10 A	55
350	332	78	419	175	400	210	993	1465	SC200	420	1550	820	SA10.2	F10 A	90
400	380	89	479	175	400	245	1083	1623	SC200	490	1690	910	SA10.2	F10 A	120
450	428	89	535	200	520	280	1180	1755	SC200	560	1820	990	SA10.2	F10 A	180
500	470	114	580	250	520	315	1333	2010	SC200	625	2028	1145	SA10.2	F10 A	245
600	560	114	680	260	635	370	1558	2360	SC250	740	2358	1370	SA10.2	F10 A	340
700	665	118	800	310	635	400	1750	2378	SC250	865	2650	1565	SA14.2	F14 A	460
750	710	118	860	305	635	430	1880	2786	SC320	930	2787	1635	SA14.2	F14 A	510
800	760	118	900	310	635	450	1970	2943	SC320	985	2970	1780	SA14.2	F14 A	600
900	855	118	1010	320	635	580	2220	3273	SC320	1160	3340	1985	SA14.6	F14 A	900
1000	950	150	1110	320	635	640	2400	3608	SC320	1280	3630	2215	SA14.6	F14 A	1500
1200	1200	150	1335	490	-	750	-	-	-	1500	4300	2860	SA16.2	F16 A	2160
1300	1300	147	1442	596	-	813	-	-	-	1626	4737	3020	SA16.2	F16 A	3300
1400	1422	180	1574	510	-	863	-	-	-	1726	4950	3224	SA16.2	F16 A	3300
1600	1560	190	1755	550	-	950	-	-	-	1900	5365	3453	SA16.2	F16 A	5000
1800	1750	247	1963	795	-	1060	-	-	-	2405	6615	4150	SA25.1	F25 A	8300

1) Recommended sizing of double-acting pneumatic cylinder type SC at normal operation with 5 bar air supply pressure. For other operating conditions, contact Stafsjö or your local representative for advice.

2) Recommended sizing of Auma SA electric motors at normal operation. For other operating conditions, contact Stafsjö or your local representative for advice.

3) Valve and Auma SA interface. The electric motors are mounted as standard according to ISO 5210 connection A (rising stem).

4) Weight in kg for valve equipped with hand wheel and electric actuator on DN 1200 - DN 1800.

5) 170 mm when supplied with stainless steel valve body and flange drilling according to ASME/ANSI B16.5 Class 150.

Main dimensions are only for information. Contact Stafsjö for certified drawings.

Flange drilling according to EN 1092 PN 10

DN	50	65	80	100	125	150	200	250	300	350	400	450
Bolt circle diameter (mm)	125	145	160	180	210	240	295	350	400	460	515	565
Number of throughgoing bolts	-	-	4	4	4	4	4	6	6	8 or 6	8 or 6	6
Number of tapped holes/side	4	4	4	4	4	4	4	6	6	8 or 10	8 or 10	14
Bolt size	M16	M16	M16	M16	M16	M20	M20	M20	M20	M20	M24	M24
Bolt lengths ¹⁾ (mm)	8 ²⁾	8 ²⁾	12	12	12	14	13	17	20	19	22	22

DN	500	600	700	750	800	900	1000	1200	1400	1600	1800
Bolt circle diameter (mm)	620	725	840	900	950	1050	1160	1380	1590	1820	2020
Number of throughgoing bolts	6	6	10	10	10	12	12	10	24	14	14
Number of tapped holes/side	14	14	14	14	14	16	16	22	12	26	30
Bolt size	M24	M27	M27	M27	M30	M30	M33	M36	M39	M45	M45
Bolt lengths ¹⁾ (mm)	27	27	25	25	27	27	30	32	40	40	55

Flange drilling according to EN 1092 PN 16

DN	50	65	80	100	125	150	200	250	300	350	400	450
Bolt circle diameter (mm)	125	145	160	180	210	240	295	355	410	470	525	585
Number of throughgoing bolts	-	-	4	4	4	4	6	6	6	8 or 6	8 or 6	6
Number of tapped holes/side	4	4	4	4	4	4	6	6	6	8 or 10	8 or 10	14
Bolt size	M16	M16	M16	M16	M16	M20	M20	M24	M24	M24	M27	M27
Bolt lengths ¹⁾ (mm)	8 ²⁾	8 ²⁾	12	12	12	14	13	17	20	19	22	22

DN	500	600	700	750	800	900	1000	1200	≥ 1400
Bolt circle diameter (mm)	650	770	840	-	950	1050	1170	1390	OR
Number of throughgoing bolts	6	6	10	-	10	12	12	10	OR
Number of tapped holes/side	14	14	14	-	14	16	16	22	OR
Bolt size	M30	M33	M33	-	M36	M36	M39	M45	OR
Bolt lengths ¹⁾ (mm)	27	27	25	-	27	27	30	32	OR

Flange drilling according to ASME/ANSI B16.5 & B16.47 Class 150

DN	50	65	80	100	125	150	200	250	300	350	400	450
Bolt circle diameter (mm)	120,7	139,7	152,4 ²⁾	190,5	215,9	241,3	298,5	362	431,8	476,3	539,8	577,9
Number of throughgoing bolts	-	-	0 ³⁾ / 2 ⁴⁾	4	4	4	4	6	6	6	8 or 6	6
Number of tapped holes/side	4	4	4 ³⁾ / 2 ⁴⁾	4	4	4	4	6	6	6	8 or 10	10
Bolt size (UNC)	5/8"-11	5/8"-11	5/8"-11	5/8"-11	3/4"-10	3/4"-10	3/4"-10	7/8"-9	7/8"-9	1"-8	1"-8	1 1/8"-7
Bolt lengths ¹⁾ (mm)	8 ²⁾	8 ²⁾	12	12	12	14	13 ⁵⁾	17	20	19	22	22

DN	500	600	700	750	800	900	1000	1200	1400	≥ 1600
Bolt circle diameter (mm)	635	749,3	863,6	914,4	977,9	1085,9	1200,1	1422,4	1651	OR
Number of throughgoing bolts	6	6	10	10	10	12	18	28	18	OR
Number of tapped holes/side	14	14	18	18	18	20	18	16	30	OR
Bolt size (UNC)	1 1/8"-7	1 1/4"-7	1 1/4"-7	1 1/4"-7	1 1/2"-6	1 1/2"-6	1 1/2"-6	1 1/2"-6	1 3/4"-5	OR
Bolt lengths ¹⁾ (mm)	27	27	25	25	27	27	33	32	40	OR

1) Add the values with the thickness of flanges, washers and gaskets.

2) The screws on the seatside has to be 3 mm longer.

3) Valid for MV in stainless steel.

4) If flanges cannot be rotated, MV in Nodular iron version has to be installed in a 22,5° angle.

5) The screws on the seatside has to be 10 mm longer for face-to-face according to MSS-SP81.

OR = On request

Flange drilling according to JIS B 2238 10K

DN	50	65	80	100	125	150	200	250	300	350	400	450
Bolt circle diameter (mm)	120	140	150	175	210	240	290	355	400	445	510	565
Number of throughgoing bolts	-	-	4	4	4	4	6	6	8	8 or 6	8 or 6	6
Number of tapped holes/side	4	4	4	4	4	4	6	6	8	8 or 10	8 or 10	14
Bolt size	M16	M16	M16	M16	M20	M20	M20	M22	M22	M22	M24	M24
Bolt lengths ¹⁾ (mm)	8 ²⁾	8 ²⁾	12	12	12	14	13	17	20	19	22	22

DN	500	600	700	750	800	900	1000	≥ 1200
Bolt circle diameter (mm)	620	730	840	900	950	1050	1160	OR
Number of throughgoing bolts	6	6	10	10	10	12	12	OR
Number of tapped holes/side	14	18	14	14	18	16	16	OR
Bolt size	M24	M30	M30	M30	M30	M30	M36	OR
Bolt lengths ¹⁾ (mm)	27	27	25	25	27	27	30	OR

Flange drilling according to AS 2129 Table D

DN	50	65	80	100	125	150	200	250	300	350	400	450
Bolt circle diameter (mm)	114	127	146	178	210	235	292	356	406	470	521	584
Number of throughgoing bolts	-	-	2	2	4	4	4	4	6	6	6	6
Number of tapped holes/side	4	4	2	2	4	4	4	4	6	6	6	6
Bolt size	M16	M16	M16	M16	M16	M16	M16	M20	M20	M24	M24	M24
Bolt lengths ¹⁾ (mm)	8 ²⁾	8 ²⁾	12	12	12	14	13	17	20	19	22	22

DN	500	600	700	750	800	900	≥ 1000
Bolt circle diameter (mm)	641	756	845	927	984	1092	OR
Number of throughgoing bolts	6	6	10	10	10	12	OR
Number of tapped holes/side	10	10	10	10	10	12	OR
Bolt size	M24	M27	M27	M30	M33	M33	OR
Bolt lengths ¹⁾ (mm)	27	27	25	25	27	27	OR

Flange drilling according to AS 2129 Table E

DN	50	65	80	100	125	150	200	250	300	350	400	450
Bolt circle diameter (mm)	114	127	146	178	210	235	292	356	406	470	521	584
Number of throughgoing bolts	-	-	2	4	4	4	4	6	6	6	6	6
Number of tapped holes/side	4	4	2	4	4	4	4	6	6	6	6	10
Bolt size	M16	M16	M16	M16	M16	M20	M20	M20	M24	M24	M24	M24
Bolt lengths ¹⁾ (mm)	8 ²⁾	8 ²⁾	12	12	12	14	13	17	20	19	22	22

DN	500	600	700	750	800	900	≥ 1000
Bolt circle diameter (mm)	641	756	845	927	984	1092	OR
Number of throughgoing bolts	6	6	10	10	10	12	OR
Number of tapped holes/side	10	10	10	10	10	12	OR
Bolt size	M24	M30	M30	M33	M33	M33	OR
Bolt lengths ¹⁾ (mm)	27	27	25	25	27	27	OR

1) Add the values with the thickness of flanges, washers and gaskets.

2) The screws on the seatside has to be 3 mm longer.

OR = On request

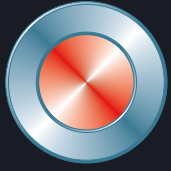

Stafsjö[®]
SINCE 1666

© Stafsjö 2024. Data is only for informational purpose. All specifications are subject to change without notice.

Stafsjö Valves AB
SE-618 95 Stavsjö, Sweden

+46 11 39 31 00 | sales@stafsjo.se | www.stafsjo.com



A Bröer Group Company