

THROTTLE VALVE CK-M



Throttle valve for clamp ring systems with pneumatic actuator type EB-SYD

TECHNICAL DATA

Nominal diameter:	DN 65 - DN 300
Face to face:	EBRO works standard
Top flange:	EN ISO 5211
Flange accommodation:	Pipe system - clamp ring groove
Temperature range:	-10°C to +130°C, (optional 220°C) (depending on pressure, media and actuator)
Operating pressure:	max. 3 bars
Body:	Aluminium
Disc:	1.4301
Annular gap body/ disc:	0,1 mm to 0,5 mm, according to application
Shaft:	1.4401; 1.4571 other materials upon request

FEATURES

- Throttle valve for clamp ring systems with centrally mounted disc
- Body with mutual bond for clamp ring connection
- Low consumption
- Fast and easy dismantling
- Maintenance-free
- Actuators: Hand lever, electric and pneumatic actuators

GENERAL APPLICATIONS

- Food industry
- Bulk goods
- Aspiration lines
- Dust separation
- Control of air/-gas flows (throttle valve)
- Exhaust pipes

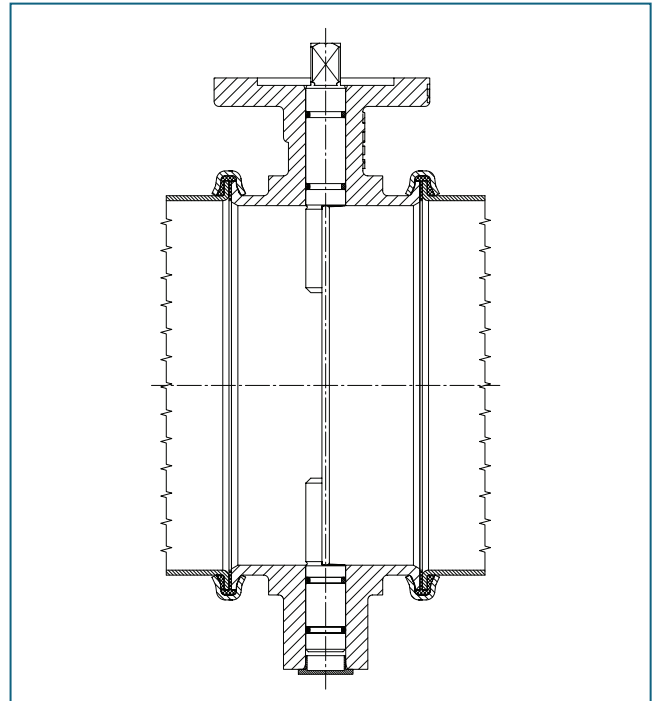

THROTTLE VALVE CK-M

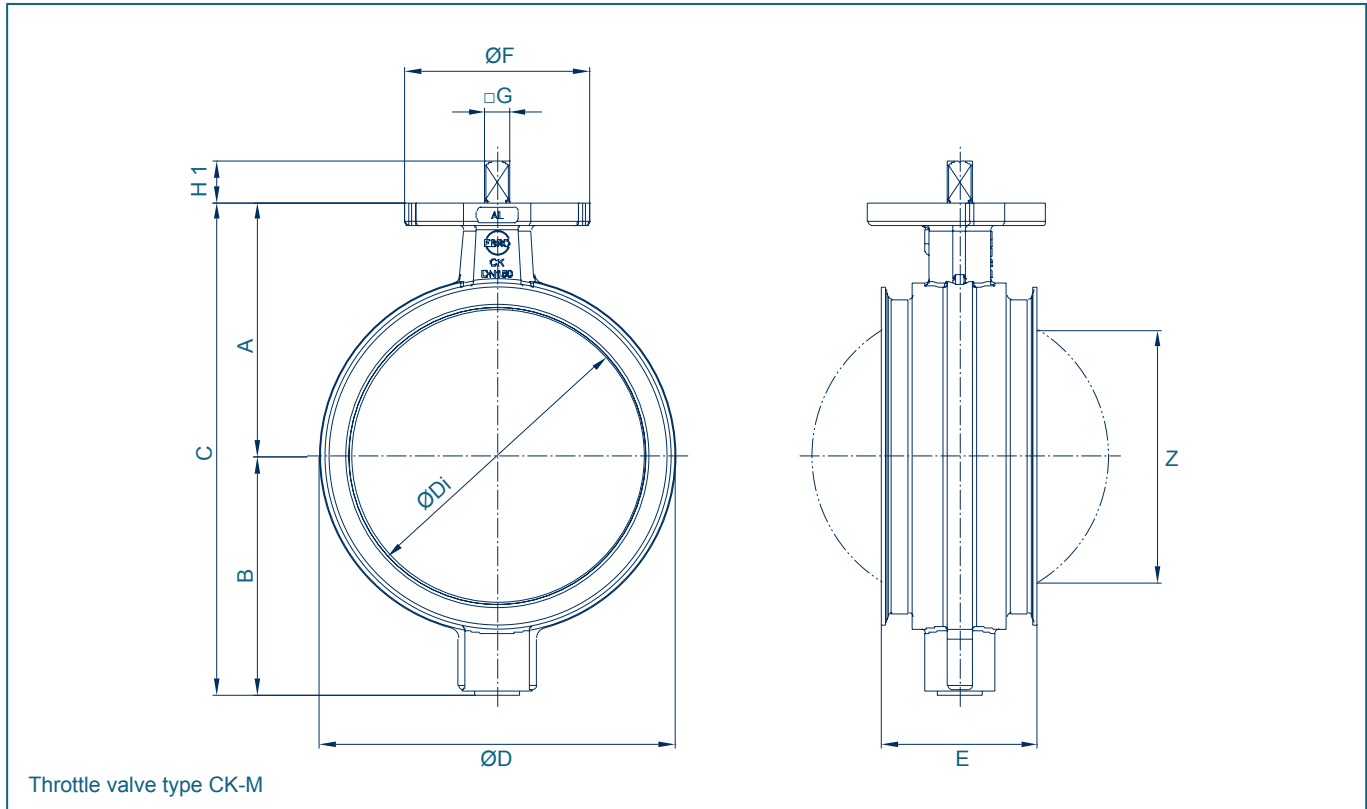

DN [mm]	Size [in]	Dimensions [mm]											Weight [kg]
		A	B	C	ØD	ØDi	E	ØF	Flange	G	H1	Z	
80	3	86	60	146	92	72	66	65	F04	11	11	28	0,7
100	4	97	92	188	115	95	68	65	F05	14	14	66	1,2
120	4¾	109	100	209	135	115	72	90	F05	14	14	90	1,7
150	6	124	115	239	165	145	76	90	F05	14	14	123	2,1
200	8	180	159	339	215	195	85	90	F07	17	17	176	4,3
250	10	206	184	390	265	245	85	90	F07	17	17	230	5,7
300	12	238	215	453	315	295	85	88	F07	17	17	283	9,4

DN [mm]	Size [in]	Actuators		
		Hand lever	Pneumatic Double acting EB-SYD	Pneumatic Spring return EB-SYS
65 - 80	2½ - 3	Size I	EB 4.1	EB 5.1
100 - 150	4 - 6	Size II	EB 4.1	EB 5.1
250 - 300	10 - 12	Size III	EB 5.1	EB 5.1

Subject to change without notice