

LUG TYPE BUTTERFLY VALVE Z 014-B



A universally applicable lug type butterfly valve with vulcanised liner according to EN 593.

TECHNICAL DATA

Nominal diameter:	DN 50 - DN 300
Face-to-face:	EN 558 Series 20 ISO 5752 Series 20 API 609 Table 1
Flange accommodation:	EN 1092 PN 6/10/16 ASME Class 150 AS2129 T/E AS4087 CL16
Flange Surface Design:	EN 1092 Form A/B ASME RF, FF
Top flange:	EN ISO 5211
Marking:	EN 19
Tightness check:	EN 12266 (Leakage rate A) ISO 5208, Category 3
Temperature range:	-10°C to +120°C (depending on pressure, medium and material)
Operating pressure:	max. 19,2 bar
Vacuum:	0,001 bar absolute

FEATURES AND BENEFITS

- Vulcanised liner for severe service conditions and Vacuum applications
- Fully lugged body for end of line services
- Triple shaft bearings prevent shaft deflection
- Accurate machining of components results in low torques and long service life
- Can be installed in any desired position
- Maintenance-free

GENERAL APPLICATIONS:

- Chemical and petrochemical industries
- Water and waste water technology
- Pneumatic materials handling technology
- Shipbuilding
- Power generation industry
- Food industry
- Mining

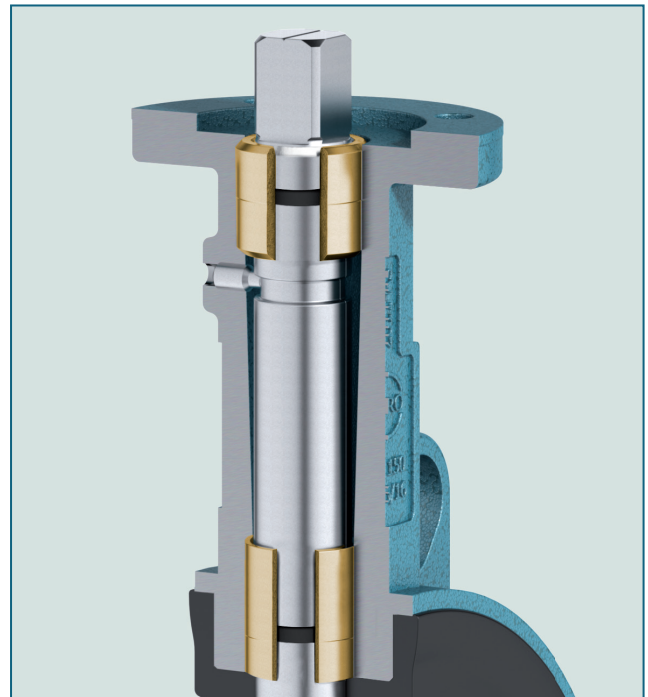

The shaft has multiple bearings. This ensures an optimal guidance even after many years of use.

LUG TYPE BUTTERFLY VALVE Z 014-B

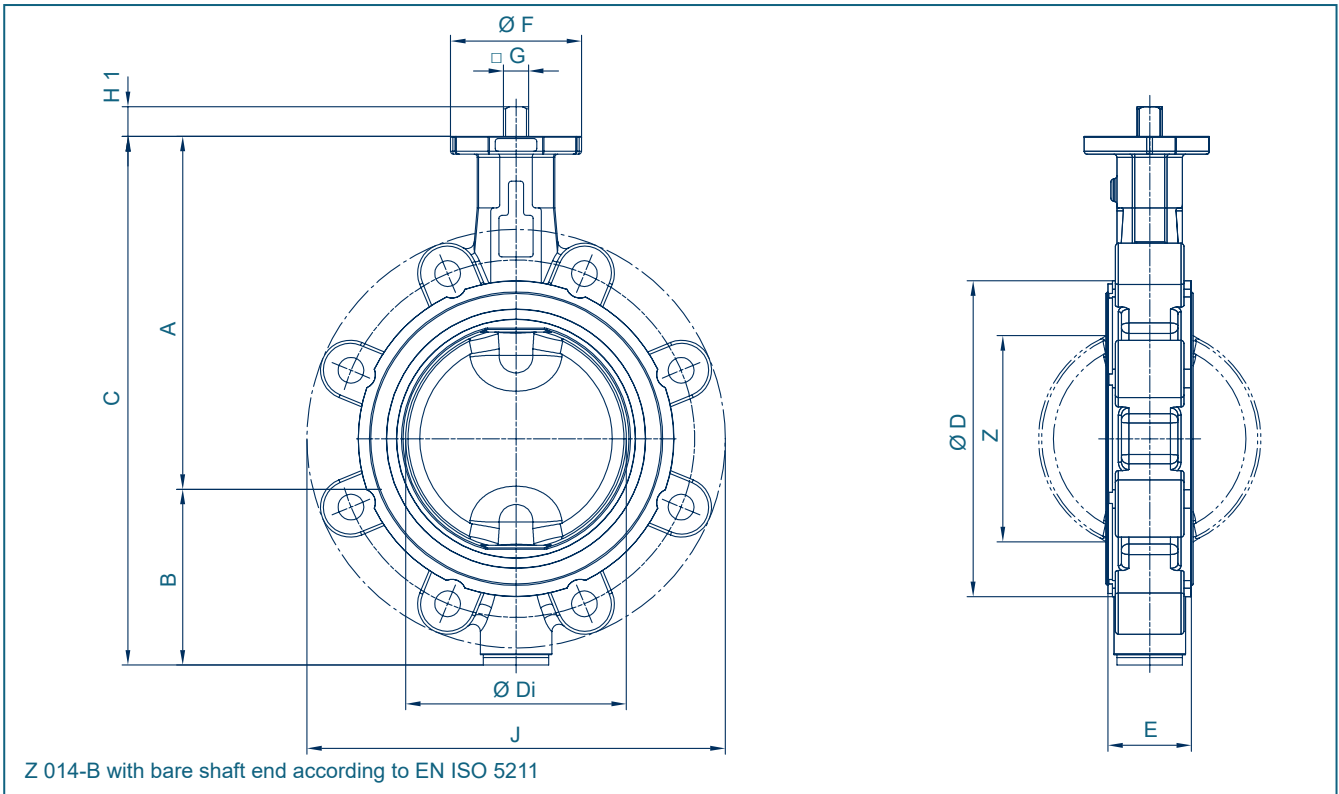

DN [mm]	Size [in]	Dimensions [mm]											Weight [kg] (EN-JS 1030)		
		A	B	C	D	Di	E	F	Flange	G	H1	J	Z	2 Piece shaft	TS- shaft
50	2	126	84	210	95	49	43	54	F04	11	12	155	25	4,8	-
65	2½	134	93	227	115	64	46	54	F04	11	12	175	45	5,5	-
80	3	157	104	261	138	79	46	65	F05	14	16	182*/190	65	8,6	9,1
100	4	167	115	282	158	98	52	65	F05	14	16	220	85	9,8	10,4
125	5	180	127	307	188	123	56	65	F05	14	16	256	111	10,1	10,7
150	6	203	150	353	212	148	56	90	F07	17	19	281	139	13,1	14,6
200	8	228	176	404	268	198	60	90	F07	17	19	338	190	18,8	20,6
250	10	266	212	478	320	248	68	125	F10	22	24	412	240	29,5	32,5
300	12	291	237	528	370	296	78	125	F10	22	24	482	287	37,0	40,5

For larger diameters, see Z 011-B (Wafer type)

*ANSI Class 150

Subject to change without notice

LUG TYPE BUTTERFLY VALVE Z 014-B

MATERIAL SPECIFICATION AND PARTS LIST

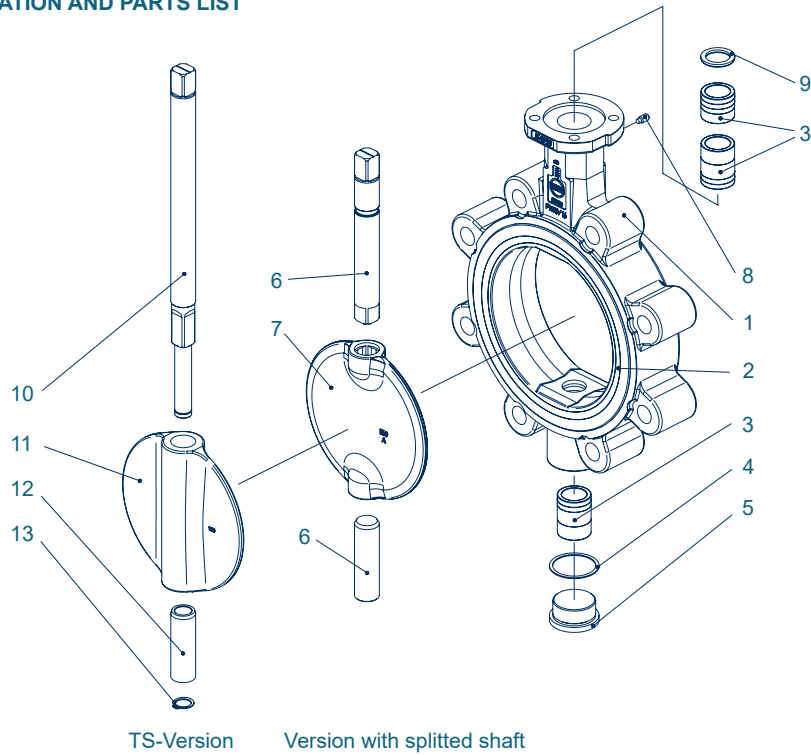

Pt.	Description	Material	Material-No.	ASTM	Pt.	Description	Material	Material-No.	ASTM
1	Body				7	Disc			
	Nodular Cast Iron	GGG-40	0.7040	60-40-18		Stainless Steel	G-X5CrNiMo19-11-2	1.4301	304
2	Vulcanised liner						G-X6CrNiMo18-10	1.4408	CF8M
	NBR	Nitrile butadiene rubber					X2CrNiMo17-12-2	1.4404	316 L
	EPDM	Ethylene propylene diene monomer rubber					X6CrNiMoTi17-12-2	1.4571	316 Ti
	CSM	Chlorosulfonated polyethylene rubber					G-X2CrNiMoN26-7-4	1.4469	F 51
	FPM	Fluorocarbon rubber			8	Plug screw DIN 915			
	VSI	Silicone rubber				Steel	45 H galvanized		
	SBR-green	Styrene butadiene rubber			9	Wiper ring			
3	Bearing bush				10	TS-Shaft	PTFE	Polytetrafluorethylene	PTFE
	Brass	MS58	2.0401	B45		See point 6			
4	Seal				11	TS-Disc			
	Copper	Cu		Copper		See point 7			
5	Plug screw DIN 908				12	Sleeve			
	Stainless Steel	G-X5CrNiMo 19-11-2	1.4408	A351-CF8M		Stainless Steel	X5CrNi18-10	1.4301	A240-304
6	Shaft				13	Retaining ring			
	Stainless Steel	X39CrMo17-1	1.4122			Stainless Steel	X39CrMo17-1	1.4122	
		X14CrMoS17	1.4104	430 F					
		X5/(X2)CrNiMo17-12-2	1.4401/1.4404	316					
		Hastelloy	2.4883	Hastelloy					
						Other materials upon request			

Subject to change without notice

LUG TYPE BUTTERFLY VALVE Z 014-B

TORQUE

- The values listed in the table are initial breakaway torques, taken with liquids and lubricant media.

- Please regard these as approximate values, as the objective value depends on different factors like pressure, medium, rubber, quality, temperature ... etc.

- Our engineers look forward to help you with exact values for your application.

- Powdery (non-lubricant) media
Md x 1,3

- Dry gases/high viscous media
Md x 1,2

DN [mm]	Size [in]	Adapted Disc Size Pressure Rating				
		3 bar disc	6 bar disc	10 bar disc	16 bar disc	19,2 bar disc
50	2	5	5	5	5	6
65	2½	7	6	8	11	13
80	3	14	10	12	17	20
100	4	9	14	20	31	36
125	5	15	22	30	41	51
150	6	36	45	55	78	90
200	8	59	140	160	200	225
250	10	150	155	210	280	320
300	12	200	200	270	350	420

All values in Nm

K_V-VALUES

- The K_V-values [m³ per hour] is the flow of water at a temperature of 5°C to 30°C (41°F to 86°F) at Δp of 1 bar

- The K_V-values specified are based on tests carried out by the Delfter Hydraulics Laboratories, the Netherlands

- Permissible velocity of flow
V_{max} 4,5 m/s for liquids,
V_{max} 70 m/s for gases

- The throttle function is linear at an angle 30° to 70°

- Avoid cavitation

For further values, please contact our engineers.

DN [mm]	Size [in]	Opening angle α°							
		20°	30°	40°	50°	60°	70°	80°	90°
50	2	3,84	10,1	20,7	34,4	49,7	65,2	79,5	91,2
65	2½	9,5	16,6	39,1	72,6	113	157	199	235
80	3	15,6	20,6	51,4	102	165	234	304	368
100	4	24,9	39,8	96,5	183	288	398	503	589
125	5	51,8	67,2	135	256	428	652	926	1250
150	6	76,5	97,3	197	375	629	957	1360	1830
200	8	137	187	373	697	1160	1760	2510	3400
250	10	227	271	563	1090	1850	2830	4010	5390
300	12	287	409	820	1550	2610	4050	5880	8120

Subject to change without notice