

WAFER TYPE BUTTERFLY VALVE Z 011-B



A universally applicable wafer type valve with vulcanised liner according to EN 593.

TECHNICAL DATA

Nominal diameter:	DN 50 - DN 600
Face-to-face:	EN 558 Series 20 ISO 5752 Series 20 API 609 Table 1
Flange accommodation:	EN 1092 PN 6/10/16 ASME Class 150
Flange Surface Design:	EN 1092 Form A/B ASME RF, FF
Top flange:	EN ISO 5211
Marking:	EN 19
Tightness check:	EN 12266 (Leakage rate A) ISO 5208, Category 3
Temperature range:	-10°C to +120°C (depending on pressure, medium and material)
Operating pressure:	max. 16 bar
Vacuum:	0,001 bar absolute

FEATURES

- Vulcanised liner
- Triple shaft bearing prevent shaft deflection
- The valve body and disc are accurately machined which results in low operating torque and long service life
- Four flange mounting holes ensure correct valve location when installing
- Can be installed in any desired position
- Maintenance-free
- Single flange mounting wafer type: DN 50 - 250: 3 bar
DN 300 - 600: 2 bar

GENERAL APPLICATIONS:

- Chemical and petrochemical industries
- Water and waste water technology
- Pneumatic materials handling technology
- Shipbuilding
- Power generation industry
- Food industry
- Civil engineering

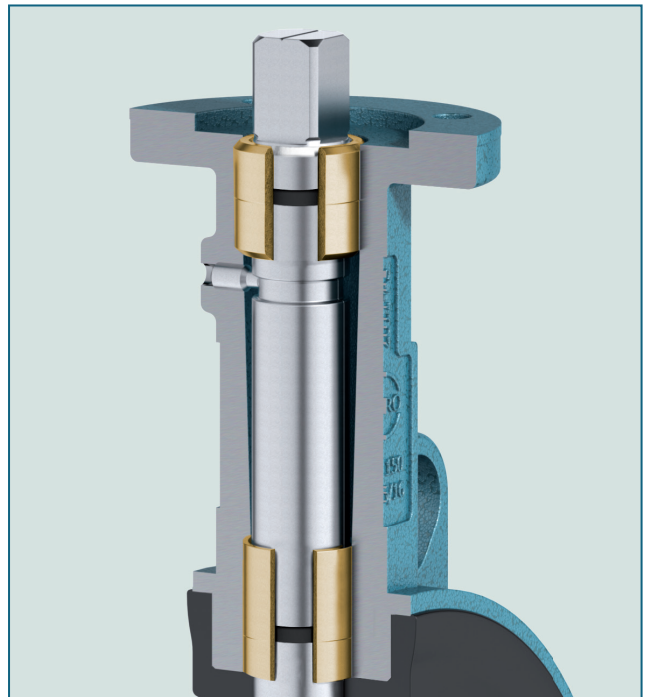

The shaft has multiple bearings. This ensures an optimal guidance even after many years of use.

WAFER TYPE BUTTERFLY VALVE Z 011-B

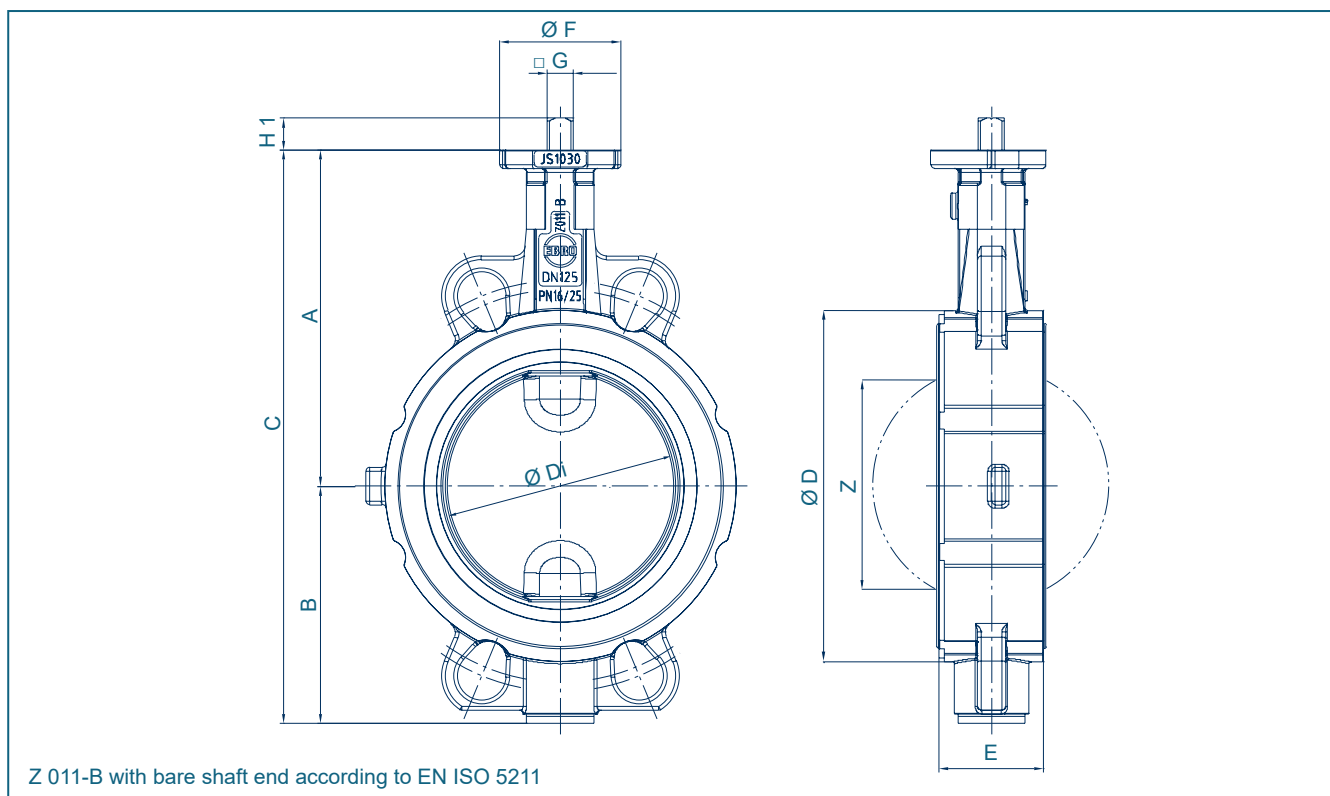

DN [mm]	Size [in]	Dimensions [mm]											Weight [kg] (EN-JS 1030)	
		A	B	C	D	Di	E	F	Flange	G	H1	Z	2 Piece shaft	TS- shaft
50	2	126	84	210	95	49	43	54	F04	11	14	25	2,5	-
65	2½	135	93	227	115	64	46	54	F04	11	14	45	3,0	-
80	3	157	104	261	138	79	46	65	F05	14	17	65	4,0	4,5
100	4	168	115	282	158	99	52	65	F05	14	17	85	5,0	5,6
125	5	180	127	307	188	124	56	65	F05	14	17	111	7,0	7,6
150	6	203	151	354	212	148	56	88	F07	17	20	139	9,5	11,0
200	8	229	177	405	268	199	60	88	F07	17	20	190	13,5	15,3
250	10	266	212	478	320	248	68	125	F10	22	24	240	22,5	25,5
300	12	291	240	531	370	296	78	125	F10	22	24	287	30,5	34,0
350	14	332	270	602	415	338	78	150	F12	27	29	330	43,5	49,1
400	16	363	314	677	473	390	102	150	F12	27	29	378	62	67,8
450	18	397	335	732	530	426	114	175	F16	36	38	417	98	102,5
500	20	437	371	808	574	489	127	175/210	F14/F16	36	38	474	110	116,5
600	24	498	435	933	675	582	154	210/300	F16/F25	46	48	563	185	212,0

Subject to change without notice

WAFER TYPE BUTTERFLY VALVE Z 011-B

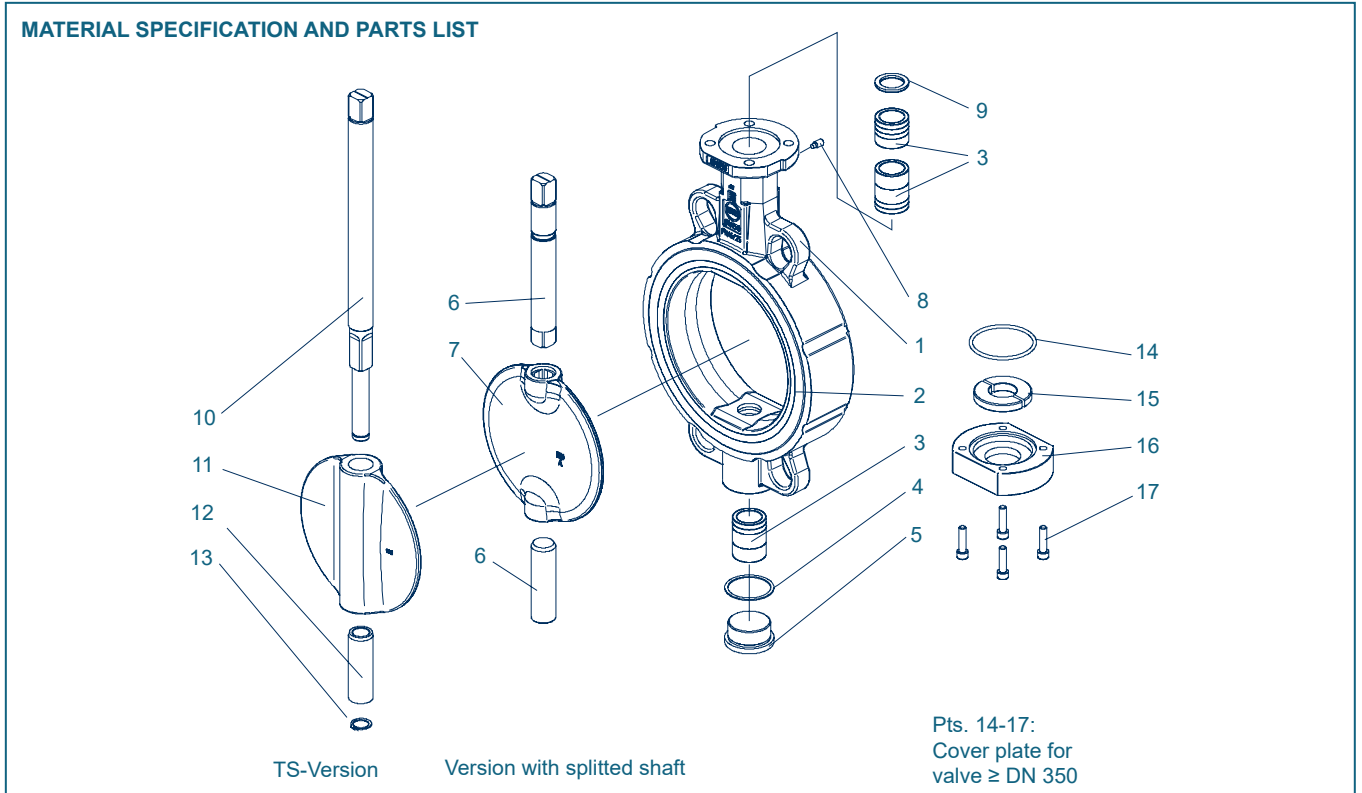

Pt.	Description	Material	Material-No.	ASTM	Pt.	Description	Material	Material-No.	ASTM
1	Body				10	TS-Shaft			
	Grey Cast Iron	EN-GJS-400-15	EN-JS 1030	A 536		Stainless Steel	X14CrMoS17	1.4104	A314-430F
2	Vulcanised liner				11	TS-Disc			
	EPDM	Ethylene propylene diene monomer rubber				Stainless Steel	G-X5CrNiMo19-11-2	1.4408	A351-CF8M
3	Bearing bush				12	Sleeve			
	Heat treated steel	42CrMo4	1.7225	A434		Stainless Steel	X5CrNi18-10	1.4301	A240-304
4	Seal				13	Retaining ring			
	Copper	Cu		Copper		Stainless Steel	X39CrMo17-1	1.4122	
5	Plug screw DIN 908				14	O-Ring			
	Stainless Steel	G-X5CrNiMo 19-11-2	1.4408	A351-CF8M		NBR	Nitrile butadiene rubber		
6	Shaft				15	Shaft retainer			
	Stainless Steel	X14CrMoS17	1.4104	A314-430F		Brass	CuZn39Pb3	2.0401	B455
7	Disc				16	Cover plate			
	Stainless Steel	G-X5CrNiMo 19-11-2	1.4408	A351-CF8M		Grey Cast Iron	EN-GLS-250	EN-JL 1040	A48-40B
8	Plug screw DIN 915				17	Screw			
	Steel	45 H galvanized				Steel	45 H galvanized		
9	Wiper ring								
	PTFE	Polytetrafluorethylene PTFE							
						Other materials upon request			

Subject to change without notice

WAFER TYPE BUTTERFLY VALVE Z 011-B

TORQUE

- The values listed in the table are initial breakaway torques, taken with liquids and lubricant media.
- Please regard these as approximate values, as the objective value depends on different factors like pressure, medium, rubber, quality, temperature ... etc.
- Our engineers look forward to help you with exact values for your application.
- Powdery (non-lubricant) media
Md x 1,3
- Dry gases/high viscous media
Md x 1,2

DN [mm]	Size [in]	Adapted Disc Size Pressure Rating			
		3 bar disc	6 bar disc	10 bar disc	16 bar disc
50	2	5	7	7	9
65	2½	7	9	15	18
80	3	14	18	24	28
100	4	9	18	25	30
125	5	15	22	45	59
150	6	36	45	80	100
200	8	59	76	140	200
250	10	150	180	200	300
300	12	200	240	280	360
350	14	350	540	640	1200
400	16	650	900	1300	1700
450	18	720	1000	1400	2000
500	20	1100	1400	2255	3000
600	24	1200	2100	3000	4000

All values in Nm

K_v-VALUES

- The K_v-values [m³ per hour] is the flow of water at a temperature of 5°C to 30°C (41°F to 86°F) at Δp of 1 bar
- The K_v-values specified are based on tests carried out by the Delfter Hydraulics Laboratories, the Netherlands
- Permissible velocity of flow
V_{max} 4,5 m/s for liquids,
V_{max} 70 m/s for gases
- The throttle function is linear at an angle 30° to 70°
- Avoid cavitation

For further values, please contact our engineers.

DN [mm]	Size [in]	Opening angle α°								
		20°	30°	40°	50°	60°	70°	80°	90°	
50	2	3,84	10,1	20,7	34,4	49,7	65,2	79,5	91,2	
65	2½	9,5	16,6	39,1	72,6	113	157	199	235	
80	3	15,6	20,6	51,4	102	165	234	304	368	
100	4	24,9	39,8	96,5	183	288	398	503	589	
125	5	51,8	67,2	135	256	428	652	926	1250	
150	6	76,5	97,3	197	375	629	957	1360	1830	
200	8	137	187	373	697	1160	1760	2510	3400	
250	10	227	271	563	1090	1850	2830	4010	5390	
300	12	287	409	820	1550	2610	4050	5880	8120	
350	14	399	488	1070	2110	3590	5480	7760	10400	
400	16	557	703	1360	2600	4470	7060	10400	14600	
450	18	716	907	1810	3440	5830	8980	13000	17800	
500	20	875	1110	2250	4280	7180	10900	15500	20900	
600	24	1230	1550	3150	6010	10090	15400	21800	29400	

Subject to change without notice