

---

**Electrical Quarter Turn Actuators**  
**Type E50 – E210**  
**For DC / AC / three-phase current**



Examples shown above, not all possible type variants are shown!

---

**Original Mounting Instructions**  
**with Operating Instructions and Technical Appendix**

**in accordance with EC Machinery Directive 2006/42/EC**

Language Version: English

# Contents

	page
<b>A) GENERAL</b>	<b>4</b>
A1 EXPLANATION OF SYMBOLS	4
A2 INTENDED USE	4
A3 IDENTIFICATION OF THE ACTUATOR	5
A4 TRANSPORT AND (INTERMEDIATE) STORAGE	6
<b>B) MOUNTING THE ACTUATOR TO THE VALVE AND ELECTRICAL CONNECTION</b>	<b>7</b>
B1 SAFETY INSTRUCTIONS FOR MOUNTING AND CONNECTION	7
B2 INTERFACES	8
B3 INDIVIDUALLY SUPPLIED ACTUATOR MOUNTING ON THE VALVE	8
B4 ALL ACTUATORS CONNECTION TO POWER SUPPLY AND THE CONTROL	11
B5 ALL ACTUATORS: ADJUSTMENT OF <CLOSED> AND <OPEN> POSITIONS	11
B6 ALL ACTUATORS TRIAL RUN: TEST STEPS TO CONCLUDE MOUNTING AND CONNECTION	13
B7 ADDITIONAL INFORMATION: DEMOUNTING THE ACTUATOR	13
<b>C) OPERATING INSTRUCTIONS</b>	<b>14</b>
C1 SAFETY INSTRUCTIONS FOR OPERATION	14
C2 ELECTRICAL OPERATION / MANUAL OPERATION	14
C3 TROUBLESHOOTING	14
<b>D) TECHNICAL APPENDIX</b>	<b>16</b>
D1 TECHNICAL SPECIFICATION OF THE ACTUATORS	16
D2 STANDARD EQUIPMENT	16
D2-1 ADAPTATION TO THE VALVE	16
D2-2 ACTUATOR OUTPUT TORQUES	16
D2-3 VALVE ASSIGNMENT	16
D2-4 CLASS OF PROTECTION	17
D2-5 HEATABLE SWITCHING SPACE	17
D2-6 THERMAL MOTOR PROTECTION	17
D2-7 ON-PERIOD	17
D2-8 INSTALLATION POSITION	17
D2-9 CORROSION PROTECTION	18
D2-10 SELF-LOCKING WHEN STATIONARY	18
D2-11 REACTION TIME OF THE CONTROL TO CONTROL SIGNALS	18
D2-12 ROTATIONAL DIRECTION DURING ELECTRICAL OPERATION	18
D2-13 MANUAL OVERRIDE	18
D3 OPTIONAL ADDITIONAL EQUIPMENT	18
D4 CONNECTION DIAGRAMS (WIRING DIAGRAMS)	22

<b>D5 TECHNICAL DATA FOR ACTUATORS, TERMINAL DIAGRAMS</b>	<b>33</b>
D5-1 TECHNICAL FEATURES OF AC ACTUATORS, STANDARD DESIGN	33
D5-2 TECHNICAL FEATURES OF THREE-PHASE ACTUATORS, STANDARD DESIGN	38
D5-3 TECHNICAL FEATURES OF DC ACTUATORS, STANDARD DESIGN	42
<b>D6 NOTES ON USER RISK ANALYSIS</b>	<b>46</b>
D6-1 NOTES ON ANALYSIS OF THE RISK FROM SUPPLY AND CONTROL VOLTAGE	47
D6-2 NOTES ON ANALYSIS OF THE RISK FROM MOVING PARTS	47
D6-3 NOTES ON RISKS FROM CONTINUOUS OPERATION	47
D6-4 NOTES ON OTHER RISKS	48
<b>D7 ORDER CODE FOR SPARE PARTS AND ADDITIONAL ASSEMBLIES</b>	<b>49</b>
<b><u>EC DECLARATION OF CONFORMITY</u></b>	<b>51</b>

---

More information and current addresses of our branch offices and resellers can be found under:





[www.ebro-armaturen.com](http://www.ebro-armaturen.com)

EBRO ARMATUREN GmbH  
Karlstraße 8  
D-58135 Hagen  
☎ (02331) 904-0  
Fax (02331) 904-111

## A) General

### A1 Explanation of symbols

Notes are denoted by the following symbols in this Operating Manual:

 xxxxxxxx	<b>Danger / Warning</b> ... indicates an immediately hazardous situation, which can result in death or severe injuries if not avoided.
	<b>Note</b> ... indicates an instruction that must be complied with.
	<b>Information</b> ... provides useful tips and recommendations
	<b>Danger / Warning</b> ...Hot surface, do not touch the surface

### A2 Intended use

Electrical quarter turn actuators of type E50 to E210 are intended for use as follows:

- with electrical power supply and control signals from system-side control,
- in ambient conditions between -20°C and +70°C (EBRO standard),
- for actuating valves with 90° turn (e.g. flap valves or ball valves) by means of
  - ▶ 230 (or 115 or 24)V AC, 50/60Hz, or
  - ▶ 400V 3-phase, 50 Hz, 60Hz or
  - ▶ 24V DC

into <OPEN> or <CLOSED> positions or into intermediate positions.

Actuators for valves which, due to their design, must be moved into a tight closed position with torque, can also be controlled load-dependently – for wiring proposals, see section D4.

This standard equipment of the actuator can also protect the valve from overloading of its functional parts.

- The actuators have a defined actuating time, suitable for continuous operation in accordance with EN15714-2 Table 1, Category C.  
A correctly connected and adjusted drive must correctly indicate the position of the valve with its electrical signals and with its visual display, and must generally close in a clockwise direction (looking at the valve drive shaft) and open anticlockwise.
- The integrated handwheel allows easy manual operation in the absence of power, with approx. 14-15 revolutions and normal manual exertion.

The self-locking reduction gear of the actuator locks the valve in any position in idle state.

The actuator's output torque and actuating time must be adapted to the valve, and its electrical design must be adapted to the control.

The actuator may only be commissioned after noting the following documents:

- The <Manufacturer's declarations regarding EC directives> enclosed with the delivery
- This EBRO Installation Manual (enclosed with the delivery)

The safety instructions in sections B1 and C1 must be observed for mounting and operation of the actuator.

	<p>Which wiring proposal is used depends on the type of valve and on the intended purpose of the actuator in general: this must be decided and selected accordingly by the planner/purchaser of the actuator. Application-typical wiring proposals can be found in section D4. The relevant terminal diagram is glued inside the switching space cover of each actuator.</p>
---	--

**Note 1:**

These instructions apply primarily in conjunction with the instructions for the valve to which the actuator is mounted; the instructions for this valve **take precedence**.

**Note 2:**

The planner/purchaser is responsible for allocation of the actuator to the valve. Appendix B of Design Standard EN15714 - 2 provides detailed information in this regard. The actuator design should allow for a 10% undervoltage – see section D2.2 in the Appendix).

**A3 Identification of the actuator**

Each actuator is identified with the following typeplate:  
Key for 7-character code **MM YY ABC** on the typeplate:

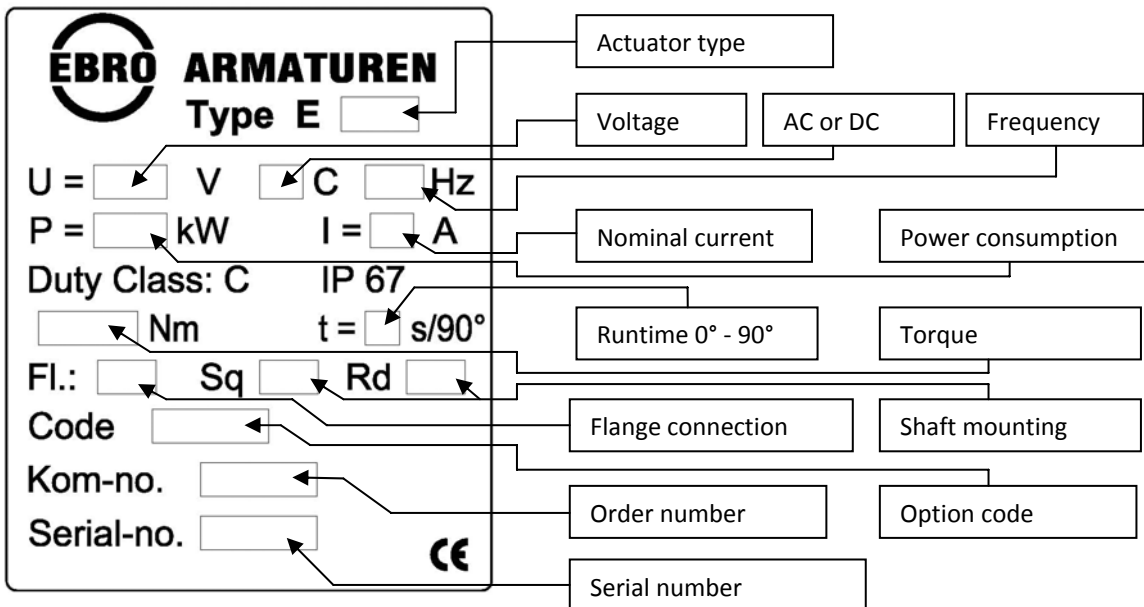

	Limit switch/Cam	Functional options	Contacts
<b>MM</b> Production month	<b>0</b> S1 & S2 for 0-90°	<b>0</b> -	<b>0</b>
<b>YY</b> Production year	<b>1</b> S1 - S4 for 0-90°	<b>1</b> Torque cut-out	<b>G</b> Gold contact
<b>Code figure A</b> Operating cam & limit switch design	<b>2</b> S1 & S2 for 0-90° S3 & S4 : freely adjustable	<b>2</b> Potentiometer	<b>I</b> Initiator
<b>Code figure B</b> Functional options	<b>3</b> S1 – S4 : freely adjustable	<b>3</b> Current feedback	<b>A</b> AS-i bus
<b>Code figure C</b> Contact type	<b>4</b>	<b>4</b> Actuating time extension	
	<b>5</b>	<b>5</b> Torque cut-out and potentiometer	
	<b>6</b>	<b>6</b> Torque cut-out and current feedback	
	<b>7</b> S1 & S2 : freely adjustable	<b>7</b> Actuating time extension (AC) and potentiometer	
	<b>8</b>	<b>8</b> Actuating time extension (AC) and current feedback	
	<b>9</b> Customer specification	<b>9</b> Customer specification	

The typeplate on the actuator housing must not be covered after mounting to the valve and after installation in the pipe section, so that the actuator remains identifiable.

#### A4 Transport and (intermediate) storage

<b>!</b>	In order to prevent corrosion damage to electrical components during storage, such components must generally be stored at a constant room temperature.
<b>!</b>	If an actuator is already mounted to the valve: The transport note and storage regulations in the valve instructions apply. In all cases, the unit must be stored in closed rooms at a constant temperature.



For correct transport of an individually supplied actuator, please note the following:  
When transporting the packages, observe the symbols on the packaging.  
Leave the actuator in the factory packaging until use (mounting to the valve).  
Always place the actuator on its flat side - the motor or handwheel must be positioned at the top or side.  
Store the actuator at a constant temperature and protect from dirt and moisture.  
Use restraining straps as a transport aid if necessary.

<b>!</b>	When attaching a strap, make sure that it is not fastened to the handwheel. Protect the actuator from damage during transport.
----------	---

## **B) Mounting the actuator to the valve and electrical connection**

This section provides all necessary information for mounting an actuator to a valve. The user is required to take account of the type-specific requirements of the valve (flap valve, ball valve) for operation of the actuator.

### **B1 Safety instructions for mounting and connection**

	<p>Mounting and electrical/electronic connection of an actuator to the operator's system(s) may only be carried out by expert qualified personnel. For the purposes of this manual, experts are persons who, on the basis of their training, technical knowledge and professional experience, are familiar with electrical high and low voltage components and can correctly assess and execute the tasks assigned to them, and can identify and eliminate potential dangers.</p> <p>Knowledge of the typical characteristics of quarter turn valves (flap valves, ball valves) is also necessary for installation; mounting and connection should be carried out in coordination with expert colleagues if necessary.</p> <p>Voltage configuration: control and feedback contacts are designed for 250V AC, motor supply contacts for 400V AC as per EN 61010-1. An overvoltage protector must be provided in the electrical system. This should comply with the requirements of Overvoltage Category II and Pollution Severity 2.</p> <p>Conductor cross-sections of 0.2 – 2.5 mm<sup>2</sup> can be connected.</p> <p>Cables may be installed in mated condition.</p> <p>Terminals must be connected or disconnected with the equipment disconnected.</p> <p>All mains supply circuits must be equipped with the necessary overcurrent protective devices.</p> <p>The relevant values can be found in the technical data in section D5.</p> <p>A separator must be provided, identified accordingly, and located in the engagement area of the actuator.</p> <p>After installation, the cables must be protected against displacement in the actuator wiring compartment.</p> <p>In accordance with EN 61010-1, the feed lines must fulfil the requirements for reinforced conductor insulation within the line for the voltage proof test.</p>
 <p><b>Risk of crushing!</b></p>	<p>The earthing / PE terminal is provided between the two cable inlets at the earthing screws (M4). Switch box cover, motor and gear housing are earthed in the factory.</p> <p>The motor control contactors must be configured in accordance with DIN VDE 660, Section 102, Usage Category AC3, which defines the control requirement for inductive loads.</p> <p>In order to avoid incorrect messages in the operator control or inaccurate signals from the torque cut-out, it must be ensured that the electrical cut-out of the actuator occurs maximum 50ms after reaching the limit switch.</p> <p>If the actuator is exposed to changing ambient temperatures, the switching space heating element must be connected to the power supply as soon as possible, in order to prevent damage due to condensation in the switching space.</p> <p>Commissioning of an actuator, which is mounted to a valve, is only permitted if the valve is enclosed on both sides by a pipe or equipment section – any prior actuation entails a risk of crushing and is under the user's sole responsibility.</p>

**B2 Interfaces**

The purchaser must ensure the conformity of the following interfaces:

Actuator/valve flange connection: with dimensions according to ISO 5211 (actuator and/or valve can have multiple bores),

Valve drive shaft/borehole, square socket/parallel key in actuator:

- ▶ shape (=square or with parallel key) must match,
- ▶ the valve manufacturer must have defined the appropriate dimensions and tolerances on the valve shaft.

**B3 Individually supplied actuator Mounting on the valve**

Use the handwheel to move the actuator – matching the position of the valve – into the <CLOSED> or <OPEN> position (maximum 15 revolutions are required), place on the valve and centre at the actuator/valve interface.

The actuator can be positioned as desired on the valve; the position can be defined in-situ.

The screw connection must be tightened so that the drive torque is transferred by frictional contact – see table below. The flange size for the actuator is specified on the typeplate.

Tighten screws crosswise.

Flange size ISO	F04	F05	F07	F10	F12	F16
Tighten with [Nm]	5-6 Nm	8-10 Nm	20-23Nm	44-48 Nm	78-85 Nm	370-390 Nm

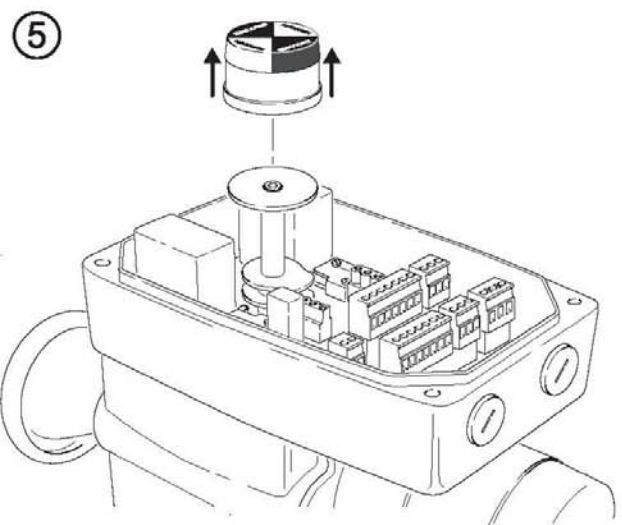
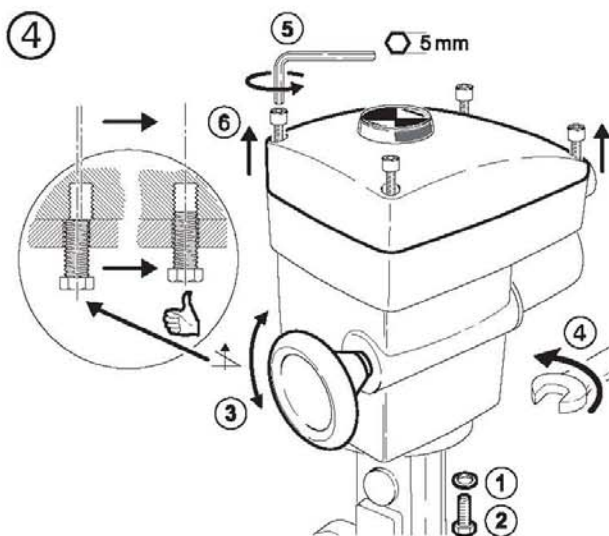
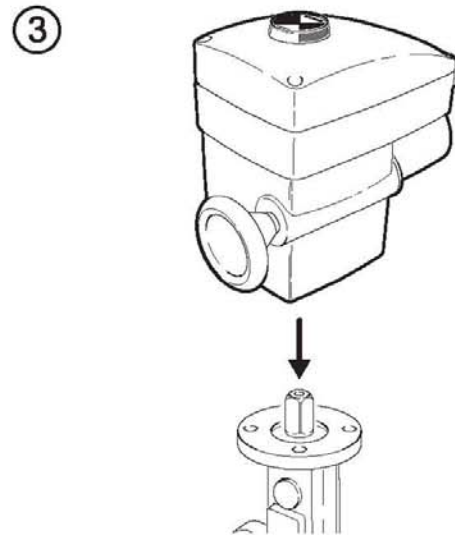
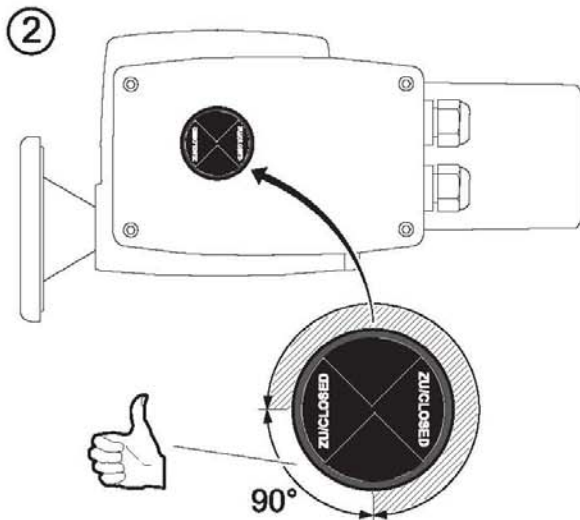
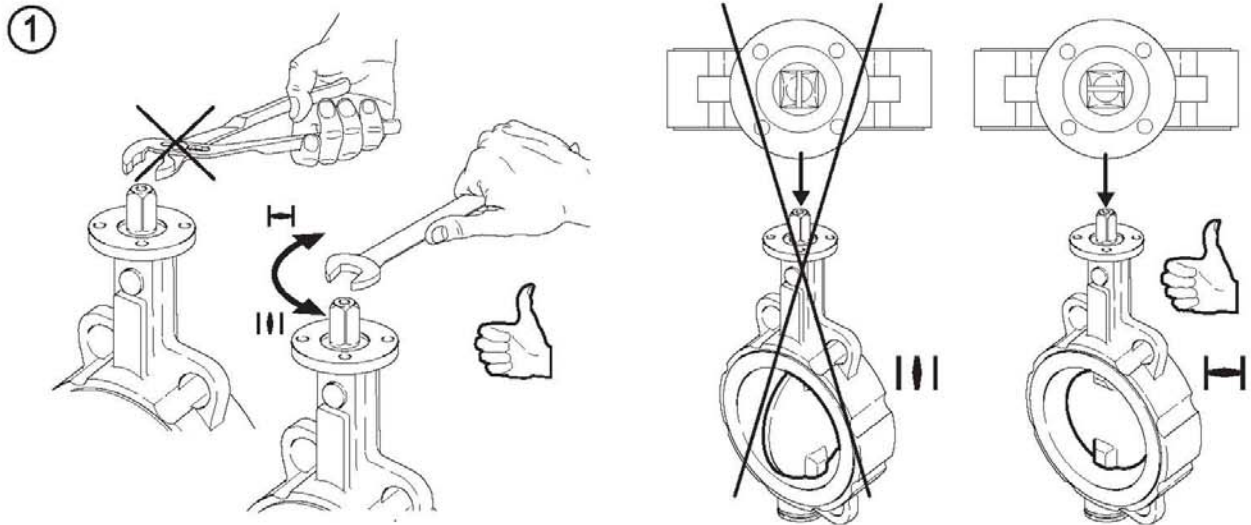

Aufbau  
Mounting

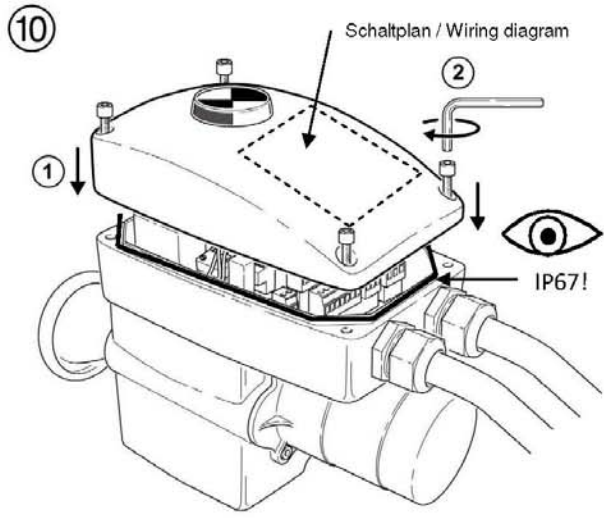
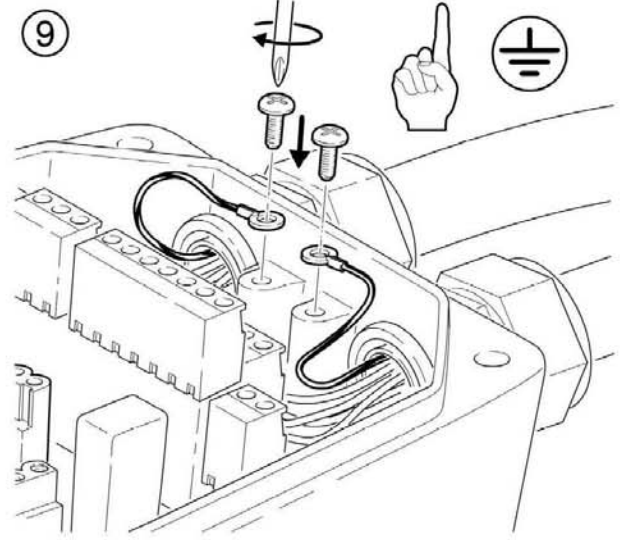
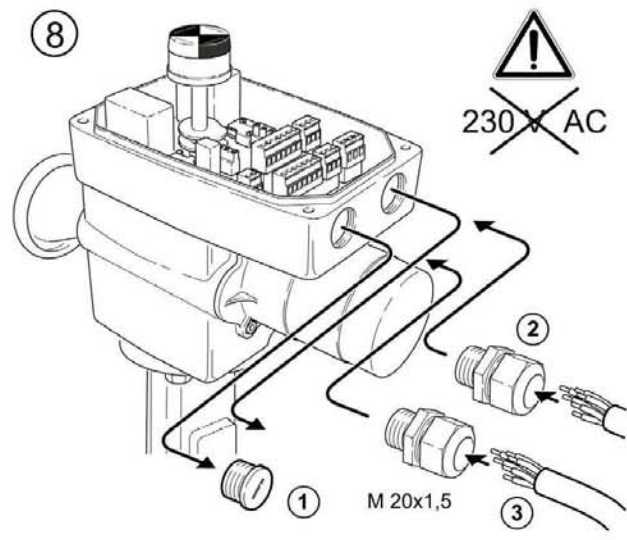
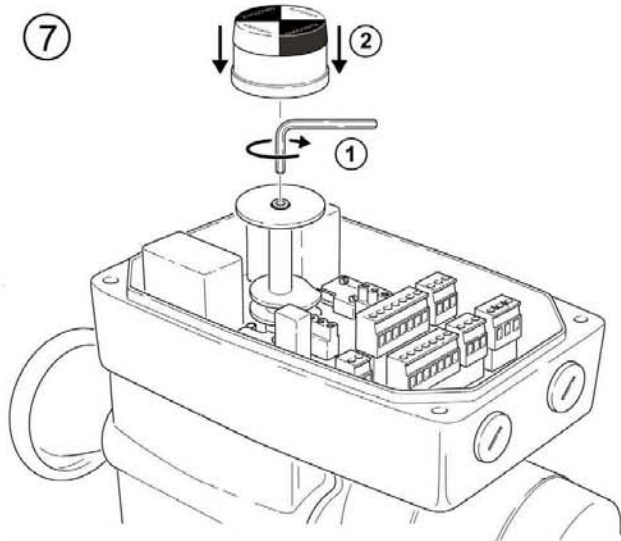
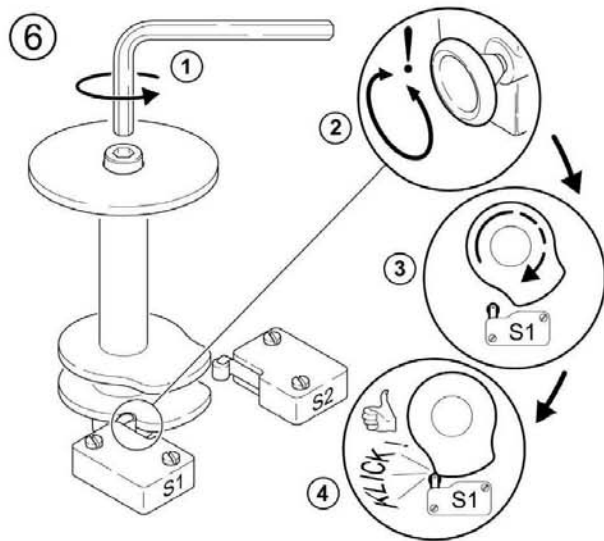





**B4 All actuators Connection to power supply and the control**

The technical data for actuators E50 - E210/WS/DS/GS can be found in section D5. The relevant terminal diagram is glued inside the switching space cover of each actuator.

	When commencing connection, it must be ensured that the system data - nominal voltage, control voltage (and frequency) match the data specified on the actuator typeplate.
	For selection of the wiring proposal (connection diagram), section D4 of the Appendix specifies that the selected connection diagram must be suitable for the function of the valve and the actuator equipment. The planner/purchaser is responsible for selecting a suitable layout, which must be implemented in the system-side control.
	The actuator motor must always be de-energized upon reaching the end position. This can be implemented directly via the limit switches (see wiring proposal on p. 24) or via the customer's control. Three-phase actuators must be connected to the power supply with <clockwise rotating field>, in order to ensure the correct direction of rotation of the actuator.

For connection to the control, unscrew the switching space cover. Conductor cross-sections of 0.2 – 2.5 mm<sup>2</sup> can be connected. The cables can also be installed in mated condition. Wiring or connection/disconnection of terminals must be carried out with the equipment disconnected. Different potentials are permitted within a cable, provided that the cable is designed for the maximum occurring voltage and current. For all entries of supply and control cables, the actuator has M20x1.5 screwed cable glands:

	<i>To ensure class of protection IP67 in accordance with EN60529:</i> ▶ All openings for cable connections are sealed with plugs in delivery condition. The cable glands must not be inserted until connecting to the control. ▶ Correct positioning of all seals on switching space cover and cable glands Only cables with sheathing Ø 6-13 mm are permitted.
	If the actuator is installed outside or in damp locations, the switching space heating must be put into operation immediately (voltage at terminals X3.1/X3.2)

**B5 All actuators: Adjustment of <CLOSED> and <OPEN> positions**

This section is only applicable if the valve manufacturer has supplied the actuator separately and the <CLOSED> and <OPEN> positions could not be accurately adjusted.

*The operating cam in the actuator is adjusted for the <CLOSED> position ex-works. If required:* Switching space cover must be open, remove position indicator, loosen Allen screw: adjust operating cam as follows:

**!** The closed valve is the reference point for adjustment. In this position, the operating cam must be adjusted so that limit switch S1 is actuated. The operating cam is then secured again. In the standard design, the <OPEN> position then results automatically. The handwheel must not be used!

**The <CLOSED> end position of the valve:**

► It must be ensured that the electrical cut-out via the limit switches occurs before a (fixed or adjustable) end stop is reached in the valve.

**!** The actuator itself also has mechanical fixed stops.

Once again it must be ensured that the electrical cut-out via the limit switches occurs before the integrated fixed stop is reached. There should be play of at least 1/2 handwheel revolution between electrical cut-out point and the fixed stop. The travel (range of rotation) of the operating cam must be as shown on the board.

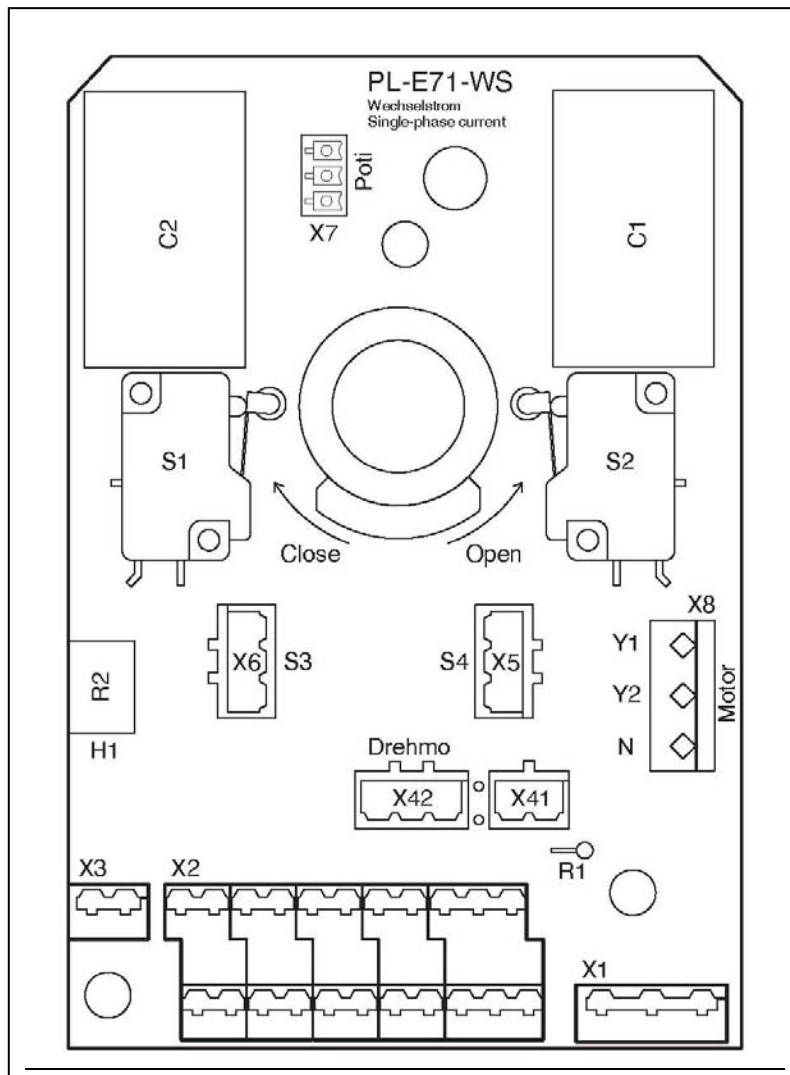

**Fix the adjusted operating cam with the Allen screw.**

Position and adjust the position indicator.  
Check electrical functions of the actuator.

	<p><i>Actuators with special equipment in the switching space:</i> Additional limit switches (S3 and S4 as option) must always be set as leading, so that the signalling is always guaranteed before the motor switches off.</p>
---	--

Before mounting the switching space cover, ensure that the O-ring seal is correctly fitted.

**B6 All actuators Trial run: Test steps to conclude mounting and connection**

To conclude, check the functioning and control of the actuator:

**Do the position indicator on the actuator and the position of the valve match ?**

If not, at least the position of the indicator must be readjusted – see B5 above.

 <b>Danger</b>	<p>Incorrect position feedback (and incorrect visual display) means danger for subsequent operation.</p>
--	--

**Has the correct connection diagram been used?**

At the <Close> control signal the valve must move into the tight <CLOSED> position:  
*Depending on the type of valve, this must be done using the limit switch (typical: ball valves and shut off flaps with rubber lining) or through load-dependent switch-off (typical for shut-off flaps with metal seal).*

Remedy: See section C3: Troubleshooting.

**Check actuating function and display:**

When nominal voltage is present, the valve must **move into the corresponding end positions** with the "**CLOSED**" and "**OPEN**" control commands. The visual display on the actuator or on the valve must indicate this correctly.

If this is not the case, the control of the actuator and/or the position of the indicator must be corrected accordingly.

**Are all electrical position indications correct:**

Electrical feedback for the "**OPEN**" and "**CLOSED**" display must be compared with the visual display on the valve. **Signal and display must match.**

If they do not, the control and/or adjustment of the position indicator must be checked.

**B7 Additional information: Demounting the actuator**

The same safety regulations must be complied with as for the pipeline system, the power supply and the (electrical) control system.

Then follow the steps below:

Mark assignment of actuator position / to valve position and record for remounting.

Interrupt power supply safely, depressurize valve if necessary.

Disconnect power supply and control cable.



Loosen flange connection of valve/actuator and remove actuator from the valve.

## C) Operating Instructions

This manual contains all necessary information for operating an actuator which is mounted to a valve.

It is assumed that when mounting and connecting to the control, the connection diagram has been adapted to the type-specific requirements of the valve (flap valve, ball valve) during operation of the actuator – also see sections B and D.

### C1 *Safety instructions for operation*

	<p>The functioning of an electrical actuator mounted to a valve must comply with the &lt;Intended use&gt;, which is described in section A2. The conditions of use must conform to the identification on the actuator typeplate.</p> <p>A standard design of actuator must be operated exclusively within the permitted temperature limits of -20 and +70°C.</p> <p>After correct installation and adaptation to the valve, the actuator is maintenance-free for continuous operation in Class C as per EN 15714-2.</p> <p>All work on the actuator may only be carried out by expert personnel. For the purposes of this manual, experts are persons who, on the basis of their training, technical knowledge and professional experience, can correctly assess and execute the tasks assigned to them, and can identify and eliminate potential dangers.</p>
 <b>Risk of crushing!</b>	<p>The operation of an actuator which is mounted to a valve is only permitted if the valve is enclosed on both sides by a pipe or equipment section – any prior actuation entails a risk of crushing and is under the user's sole responsibility.</p>

#### Additional note

- In accordance with MD 2006/42/EC the system planner must prepare a comprehensive risk analysis. The manufacturer EBRO-Armaturen makes the following documents available for this purpose:
- Mounting instructions in accordance with EC Machinery Directive 2006/42/EC – see section B of this manual.
- Checklist for actuator-typical risks – see section D6.

### C2 *Electrical operation / Manual operation*

**If the actuator is correctly connected in accordance with section B, it will operate automatically and is maintenance-free for operating mode <C> as per EN15714-2, Table 1.**

The actuator can be manually operated in non-electrical mode at any time, without conversion; normal manual exertion (also see EN12570) is required.

### C3 *Troubleshooting*

**When eliminating malfunctions, you can use the following table to check whether to search for the fault in the actuator or in its control, or in a malfunction of the valve:**

Typ. fault characteristic	Possible cause	Note / Measures
Actuator will not start	Thermal overcurrent switch has triggered	Only applies for DC actuators
	Thermal switch has triggered	For AC and 3-phase actuators; resets automatically after cooling down
Motor gets very hot	On-time too long	Check cycle times
	Incorrect wiring	Compare existing wiring with wiring proposals
	Incorrect rotary field	Apply clockwise rotating field
	Mechanical stop is reached before the limit stop becomes active	Adjust operating cam
	Check valve torque	Compare with manufacturer's data
Torque cut-out actuates	Valve torque too high	Compare with manufacturer's data
	Chosen setting too low	Adjust torque cut-out
	Actuator hitting mechanical stop	Adjust operating cam
	Blockage in pipe	Check valve and pipe
Actuators "hunting"	Non-permissible parallel connection	Electrically decouple actuator controls from each other
Control contacts stick / burn	Inadequate dimensioning of load circuit relays	Use control contactor with switching category AC3
Condensate formation in actuator	Heating not connected	Permanently supply heating with voltage
	Seal set or screwed cable gland defective	Check and correct if necessary

## **D) Technical Appendix**

### **Note:**

This Appendix is not part of the <Original Mounting Instructions>, but simply provides additional information. The planner/purchaser must ensure that the actuator is suitable for

- ▶ the valve on which it is mounted
- ▶ the system-side power supply and the control system.

Important technical information in this regard is provided below.

### **D1 Technical specification of the actuators**

All electrical quarter turn valves of type E50 to E210 comply with the requirements of Design Standard EN 15714 Industrial valves – Actuators – Part 2: Electrical quarter turn actuators.

### **D2 Standard equipment**

#### **D2-1 Adaptation to the valve**

Electrical quarter turn actuators E50 to E210 can be mounted on all quarter turn valves (generally 90°), which have a mounting flange as per EN ISO 5211.

Generally the actuator is switched off (in the end positions of the valve) travel-dependently via the integrated limit switches S1 and S2, which are used to switch off the power supply to the motor.

Load-dependent switch-off (e.g. for metal sealing valves) can be implemented

- ▶ with appropriate selection of the wiring proposal in the system-side control,
- ▶ and by means of appropriate adjustment of the (optionally available) torque cut-out <D1> in the actuator.

#### **D2-2 Actuator output torques**

The output torques of the actuators specified in section 5 are nominal torques. They are achieved under all operating conditions, when the supply voltage is equal to the nominal voltage.

	<p>The output torque changes with the <sup>(2)</sup> currently operative supply voltage:</p> <ul style="list-style-type: none"> <li>▶ Overvoltages of up to 10% of the nominal voltage are covered by the actuator design,</li> <li>▶ Undervoltages of up to 10% must be taken into account by the planner/purchaser when selecting the actuator size – also see D2.3 below.</li> </ul>
---	---

#### **D2-3 Valve assignment**

The fundamental influencing factors for the required operating torque are determined by the valve (nominal width), the operating pressure and the medium. The necessary operating torque for the valve results from these parameters.

It is recommended that a safety reserve of 15% to 20% is added to the value specified by the valve manufacturer for the design of the actuator.

With this safety reserve, which at least covers potential undervoltages, the nominal torque of the actuator must be above the operating torque of the valve, in order to guarantee fault-free operation.

#### D2-4 Class of protection

The design of actuator series E50 to E210 fulfils class of protection IP67 in accordance with EN IEC 60529.

The user must ensure professional electrical and mechanical installation, in order to ensure compliance with this class of protection IP67.

#### D2-5 Heatable switching space

The user must ensure that, for external use or use in rooms with a high air humidity and/or changing temperature, the switching space heating is put into operation **immediately after installation of the actuator** (connection to the rated voltage as per the typeplate).

#### D2-6 Thermal motor protection

AC and three-phase actuators have an integrated thermostatic switch in the winding, which triggers upon reaching the permissible maximum temperature and interrupts the power supply to the motor. The motor stops, cools down and the thermostatic switch is reset automatically. DC actuators have a thermal overcurrent switch, which switches off the voltage if the motor current becomes unacceptably high. This overcurrent switch is **not reset automatically**. It must be reset manually in the actuator switching space.

Motor protection switches should only be provided on the system side if required for plant-specific reasons.

#### D2-7 On-period

Quarter turn actuators E50 to E210 fulfil the Class C on-period as per EN 15714-2, (Classes A and B are covered by Class C).

For Class C the following applies:

(with ambient temp. <40°C)	E50/E65	up to max. 1200 start-ups per hour
	E110	up to max. 600 start-ups per hour
	E160	up to max. 600 start-ups per hour
	E210	up to max. 300 start-ups per hour

With a higher ambient temperature, this switch-on limit should be reduced by approx. 10%.

#### D2-8 Installation position

The valve/quarter turn actuator unit can be installed in any position:

This unit can be mounted in any position in the pipe system, but:

- ▶ Arrangement above the valve is the normal position for an actuator,
- ▶ The design of the valve can restrict the possible installation positions,
- ▶ If the valve shaft is horizontally positioned, the system planner or valve manufacturer must decide whether an actuator (particularly with large dimensions) will exert an unacceptable torsional moment on the valve and/or pipe, and must therefore be supported in-situ.

### **D2-9 Corrosion protection**

This corresponds to Corrosion Category C4, according to EN 15714-2 for electrical actuators. The actuators have been successfully subjected to a type test in salt mist as per EN 60068-2-52 (in accordance with the requirements of Germanischer Lloyd). Test parameter was intensity level 4 over a period of 14 days – this defines the field of application of actuators for industrial systems and/or in an ambient atmosphere with a high salt concentration.

### **D2-10 Self-locking when stationary**

All quarter turn actuators are equipped with a self-locking wormgear. This ensures that the actuator remains in the end positions even when de-energized, as well as in the last position moved to in intermediate position. The medium cannot influence the position of the valve disk.

### **D2-11 Reaction time of the control to control signals**

In order to prevent malfunctions in the shut-off device (flap disk, ball) or incorrect signals, it must be ensured on the system side that switch-off of the actuator occurs at the latest 50ms after reaching the limit position.

### **D2-12 Rotational direction during electrical operation**

Design standard EN 15714-2 defines that the valve must close in a clockwise direction when operated. This must be achieved in-situ by correct connection of the actuator to power supply and control – section B <Mounting ..., connection, trial run> provides the necessary information in this regard.

### **D2-13 Manual override**

The manual override is a revolving handwheel, which acts directly on the wormgear without a clutch. This enables the user (with the motor de-energized) to close or open the valve with a maximum of approx. 15 revolutions at any time.

The safety regulations according to EU Directive 2006/42/EC for revolving handwheels are fulfilled.

## **D3 *Optional additional equipment***

### **For AC actuators:**

- Additional potential-free limit switches (S3 and S4)
- Freely adjustable limit switches (S1 and S2) for limitation of the disk angle
- Freely adjustable intermediate position switches (S3 and S4) for signalling within the operating range
- Potentiometer
- 4-20mA current feedback using two-wire technology
- Integrated electronic torque cut-out (only E65)
- Integrated actuating time extension
- Initiators for signalling
- Led-through thermostatic switch
- Special voltages

**For three-phase actuators:**

- Additional potential-free limit switches (S3 and S4)
- Freely adjustable limit switches (S1 and S2) for limitation of the disk angle
- Freely adjustable intermediate position switches (S3 and S4) for signalling within the operating range
- Potentiometer
- 4-20mA current feedback using two-wire technology
- Integrated electronic torque cut-out
- External actuating time extension
- Initiators for signalling
- Led-through thermostatic switch
- Special voltages

**For DC actuators:**

- Freely adjustable limit switches (S1 and S2) for limitation of the disk angle
- Freely adjustable intermediate position switches (S3 and S4) for signalling within the operating range
- Potentiometer
- 4-20mA current feedback using two-wire technology
- Initiators for signalling
- Special voltages

**For all actuators:**

- Special colours

These options are described in detail below

**Option - additional limit switches**

All actuators can be equipped with additional limit switches (S3 and S4). These limit switches serve for signalling the end positions to the control. They are primarily used when actuator control and signalling have a different voltage potential. Switches that are used for signalling must always be set as leading (approx. 1°-2°), in order to ensure safe operating states of the control. All switches are generally led potential-free to the terminals.

**Note:**

*With DC actuators, limit switches S1 and S2 are used exclusively for rotational direction control. They are not led to the terminal strip, and therefore the user has no access to these switches. If feedback is required via switch, the additional limit switches S3, S4 must be used.*

**Option - electronic torque cut-out for E65**

A torque cut-out is optionally available for E65 on AC and three-phase actuators. All base boards for the control of these actuators are prepared for torque cut-out. They can be retrofitted with the relevant assembly quickly and easily if required.

**Option - freely adjustable position switches (intermediate position switches)**

All limit switches can be converted to freely adjustable limit switch cut-out by replacing the standard control cam (*see section B5*).

The user can assign a switching point of his choice to every switch within the available travel. As this modification only relates to mechanical components, it does not affect the terminal diagrams (in section D4) or the electrical data for the actuators.

Applications with a requirement to limit the actuator travel for the closed and/or open position, or to indicate intermediate positions within the travel or define these as stop points, must be implemented with (a maximum of 4) freely adjustable additional switches.

Actuators for applications in which more than 4 signalling processes must be realized within the travel, must be equipped with a potentiometer – see below.

**Option - potentiometer**

For continuous position feedback the actuators can be equipped with a potentiometer, which is mechanically coupled to the valve shaft. A 1k $\Omega$  potentiometer designed for 1W is available as standard – other values on request.

**Option - additional thermostatic switch for signalling**

For AC and three-phase actuators, digital signalling of the motor temperature can be provided in addition:

A second thermostatic switch (executed as break contact) switches approx. 10°K earlier than the standard thermostatic switch installed (this automatically causes switch-off of the actuator).

This ensures that the user receives an indication that critical motor temperature may be reached via this second thermostatic switch, before the standard thermostatic switch interrupts the motor current.

**Option - 4–20mA current feedback**

The potentiometer signal, which detects the position of the valve disk, is converted into a 4-20mA signal by a downstream converter electronics unit.

This option is recommended if the feedback signal must be transmitted over larger distances, as line losses do not influence the measuring result. This feedback type is recommended for line lengths >100m. Otherwise the same usage criteria apply as for a potentiometer.

**Option - actuating time extension for AC actuators**

In order to increase the total actuating time of the actuator, the motor is electronically synchronized. A predefined pulse generates a turn of 1° - 2° at the valve disk. This is followed by a pause until the next pulse. This pause can be adjusted using a potentiometer - the total actuating time of the actuator can thus be varied between 30s and 180s.

Every base board for AC actuators is prepared for the installation of this actuating time extension, which can be inserted on the base board instead of the torque cut-out. A combination of actuating time extension and torque cut-out is not possible as standard.

**Option - actuating time extension for three-phase actuators**

The actuating time extension for three-phase actuators is available in an additional electrical module. It should be mounted in the switch cabinet rather than in the actuator, and should be wired between motor and reversing contactors. The mode of operation is similar to the actuating time extension for AC actuators.

**Option - initiators for end position feedback**

For bounce-free, electronic end position feedback, initiators with the same design as the limit switches can be used as an option. These initiators are available in two-wire and three-wire versions. Further technical details on request.

**Option - special voltages and special motors**

In addition to the standard voltages - see technical data in section D5 – all actuators can also be configured for other voltages.

Further technical details on request.

**Option - connector system**

All actuators are optionally available with different connector systems. Unless specified otherwise, the brand <Phoenix contact> is used.

**Option - special colours**

As a variation to the standard painting of the actuators (*black, matt*), any other colour is available at customer request. The RAL number must be specified.

**D4 Connection Diagrams (wiring diagrams)**

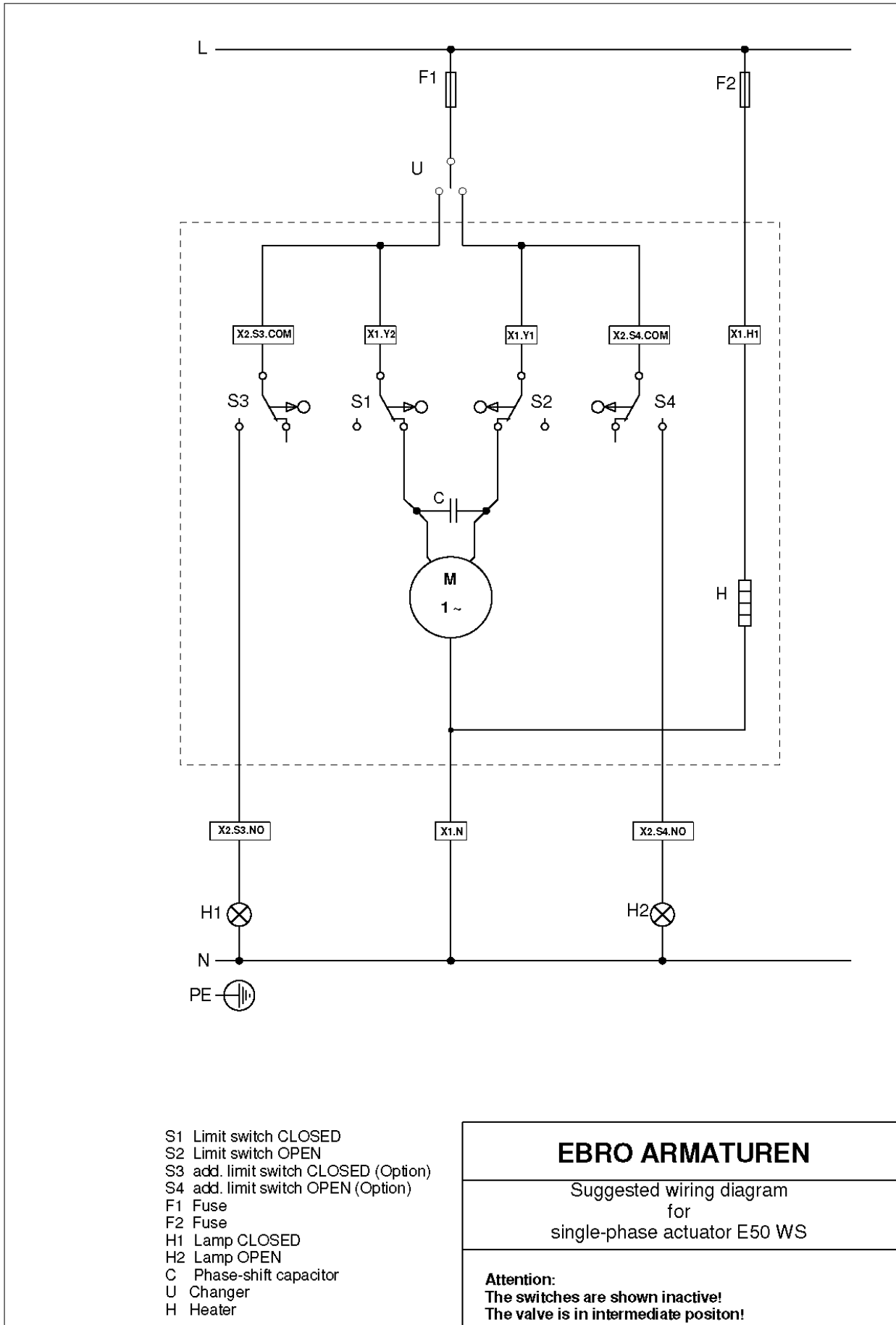

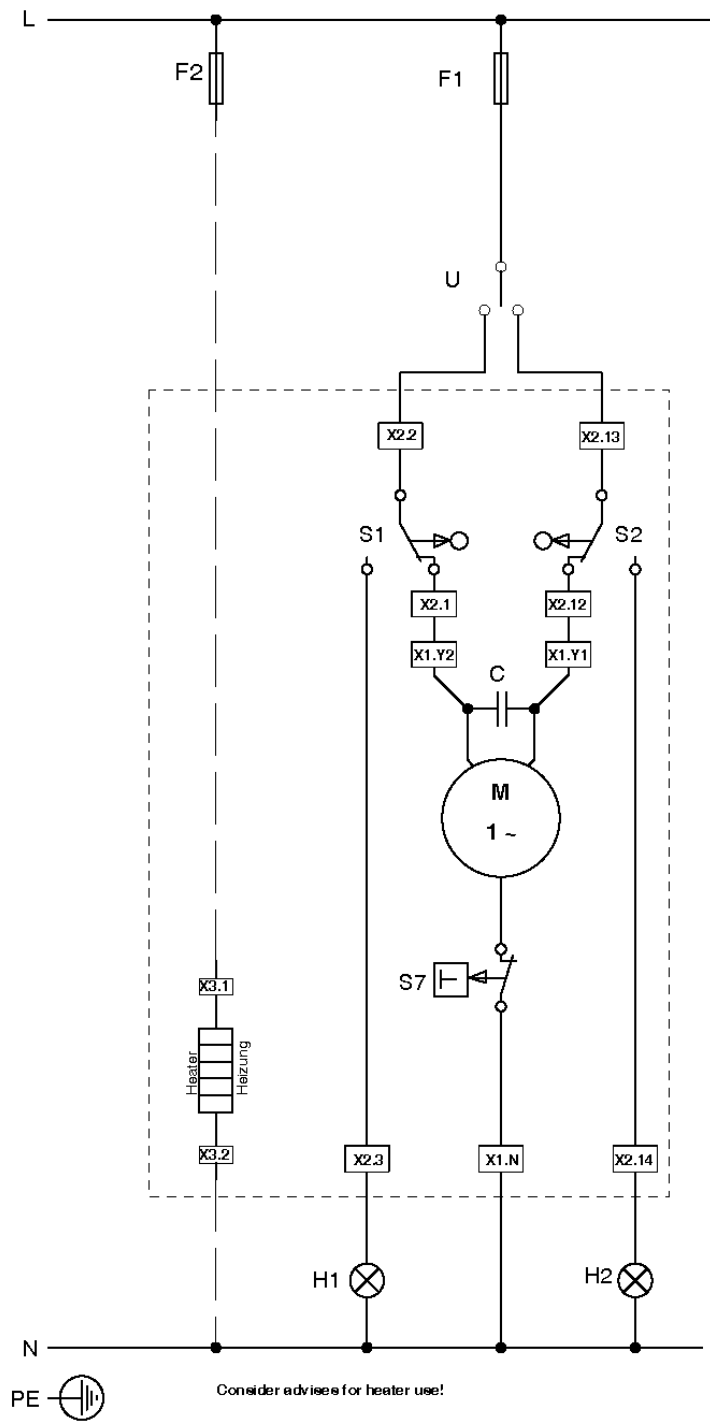

- S1 Limit switch CLOSED
- S2 Limit switch OPEN
- S7 Thermal switch integrated
- F1 Fuse
- H1 Lamp CLOSED
- H2 Lamp OPEN
- C Phase-shift capacitor
- U Open - Closed control switch

## EBRO ARMATUREN

Suggested wiring diagram for single-phase actuators without electronic torque control

**Attention:**  
The switches are shown inactive!  
The valve is in intermediate position!



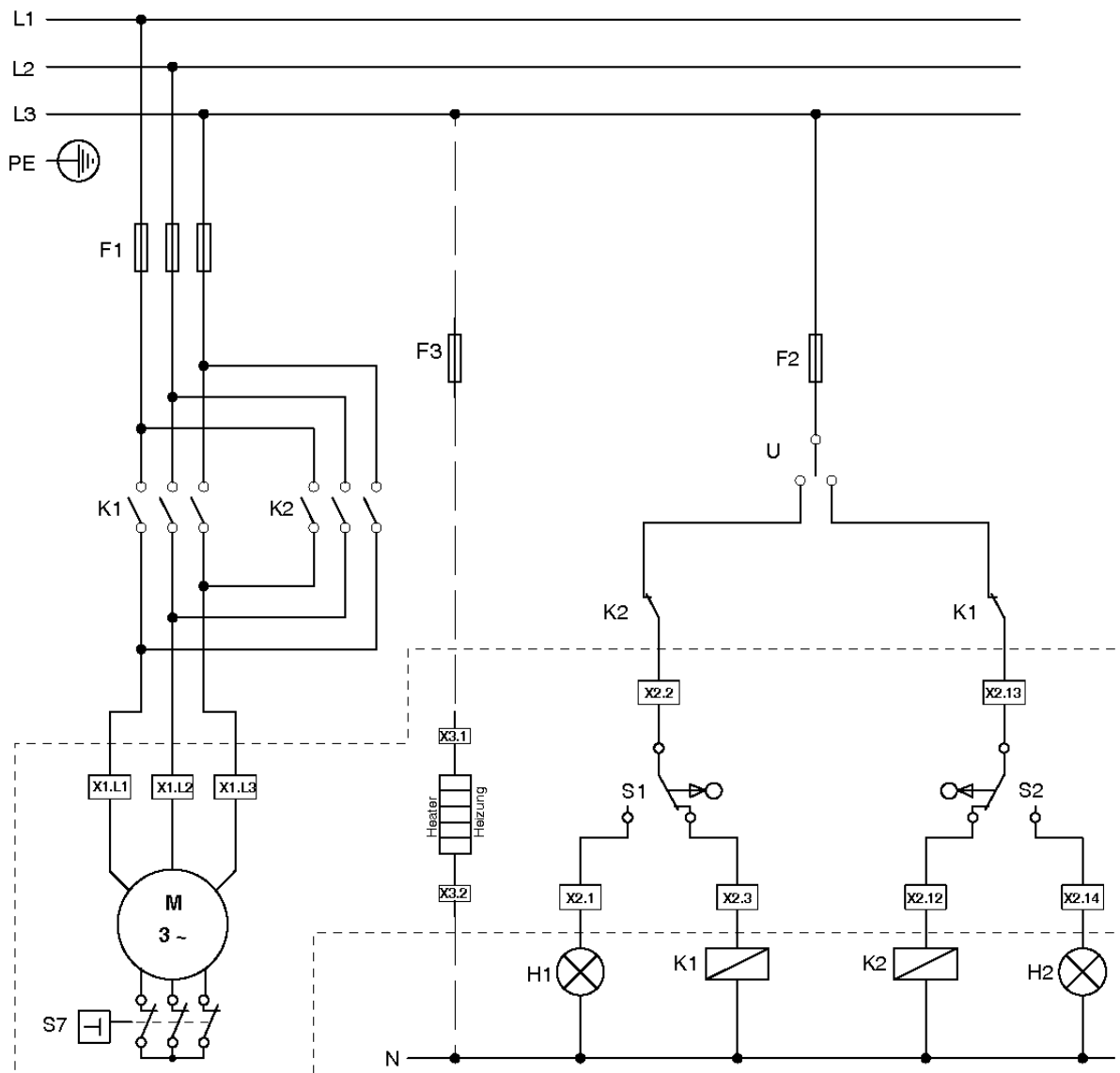

Consider advises for heater use!

- S1 Limit switch CLOSED
- S2 Limit switch OPEN
- S7 Thermal switch integrated
- U Open - Closed control switch
- K1 Contactor CLOSED
- K2 Contactor OPEN
- F1 Motor fuses
- F2 Control fuse
- F3 Heater fuse
- H1 Lamp CLOSED
- H2 Lamp OPEN

## EBRO ARMATUREN

Suggested wiring diagram for three-phase actuators without electronic torque control

**Attention:**  
The switches are shown inactive!  
The valve is in intermediate position!

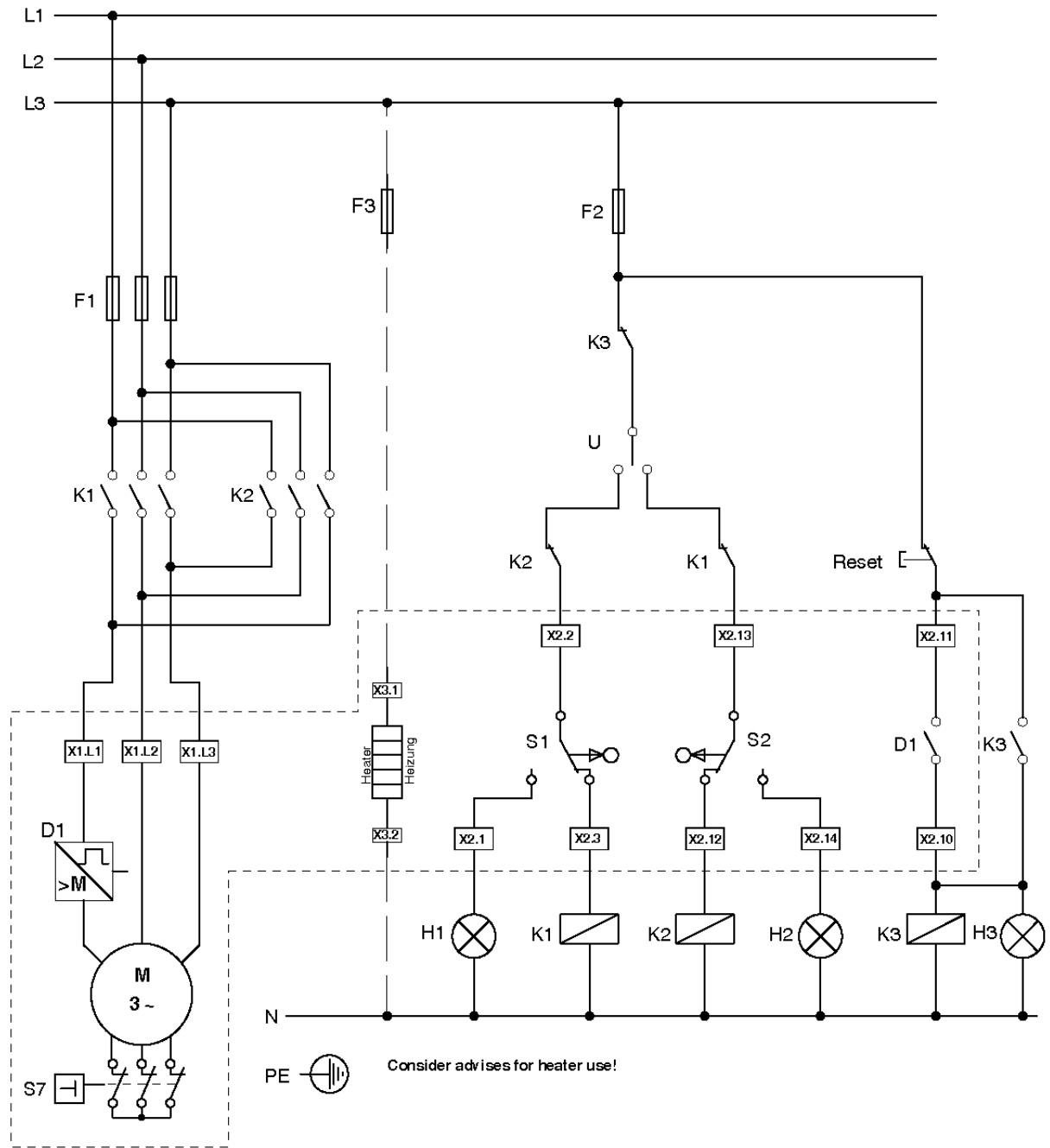

- S1 Limit switch CLOSED
- S2 Limit switch OPEN
- S7 Thermal switch integrated
- U Open - Closed control switch
- K1 Contactor CLOSED
- K2 Contactor OPEN
- K3 Auxiliary contactor
- D1 Torque control
- H1 Lamp CLOSED
- H2 Lamp OPEN
- H3 Torque control detection
- F1 Motor fuses
- F2 Control fuse
- F3 Heater fuse

Consider advises for heater use!

## EBRO ARMATUREN

Suggested wiring diagram for three-phase actuators with electronic torque control

**Attention:**  
 The switches are shown inactive!  
 The valve is in intermediate position!

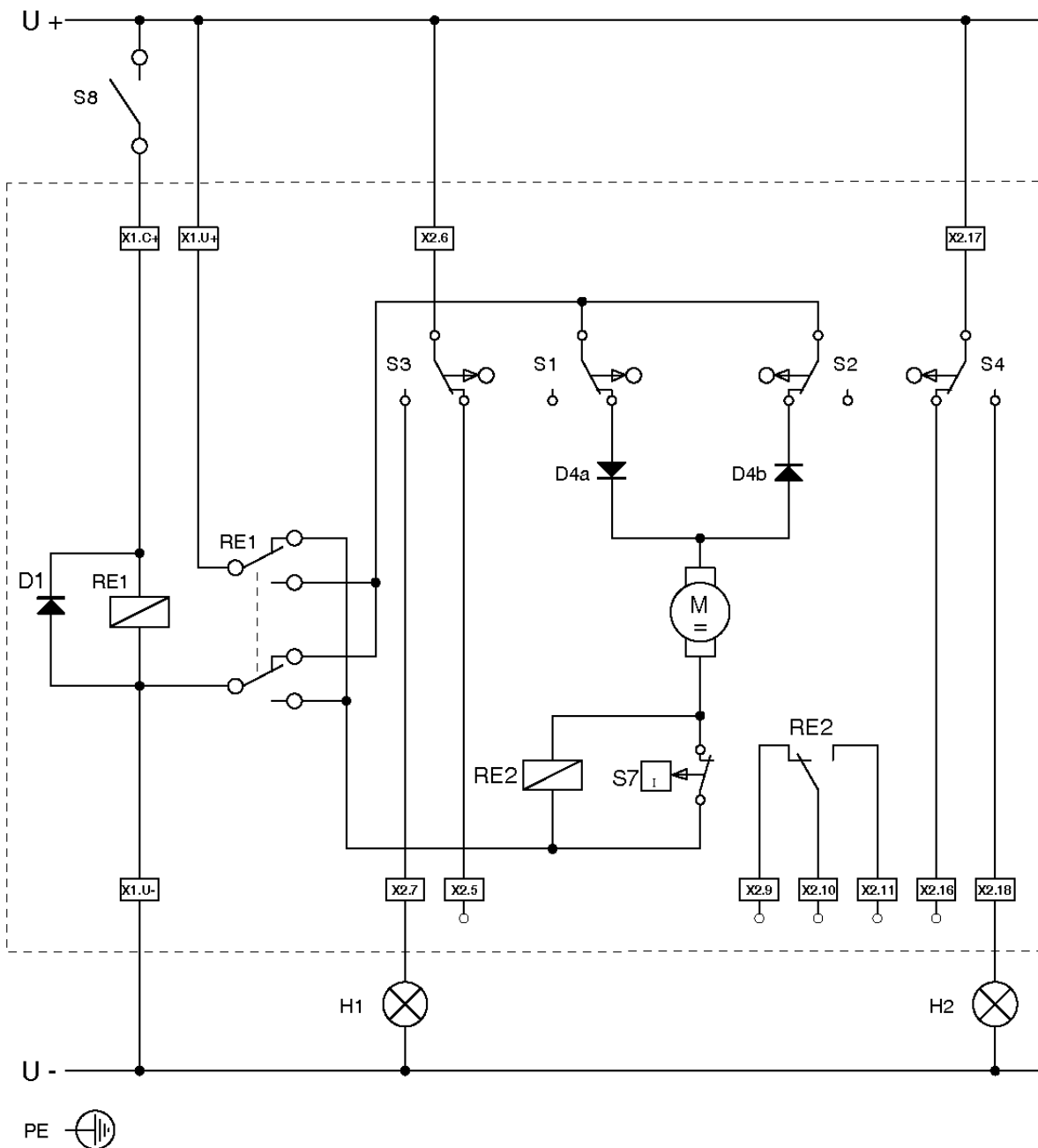

- S1 Limit switch CLOSED
- S2 Limit switch OPEN
- S3 add. limit switch CLOSED
- S4 add. limit switch OPEN
- S7 Thermal over-current circuit breaker
- S8 Direction control contact
- D1 Protection diode
- D4a,b Control diodes
- RE1 Direction changer relay
- RE2 Overload signal
- H1 Lamp CLOSED
- H2 Lamp OPEN

## EBRO ARMATUREN

Suggested wiring diagram  
for  
DC - actuators

**Attention:**  
The switches are shown inactive.  
The valve is in intermediate position.

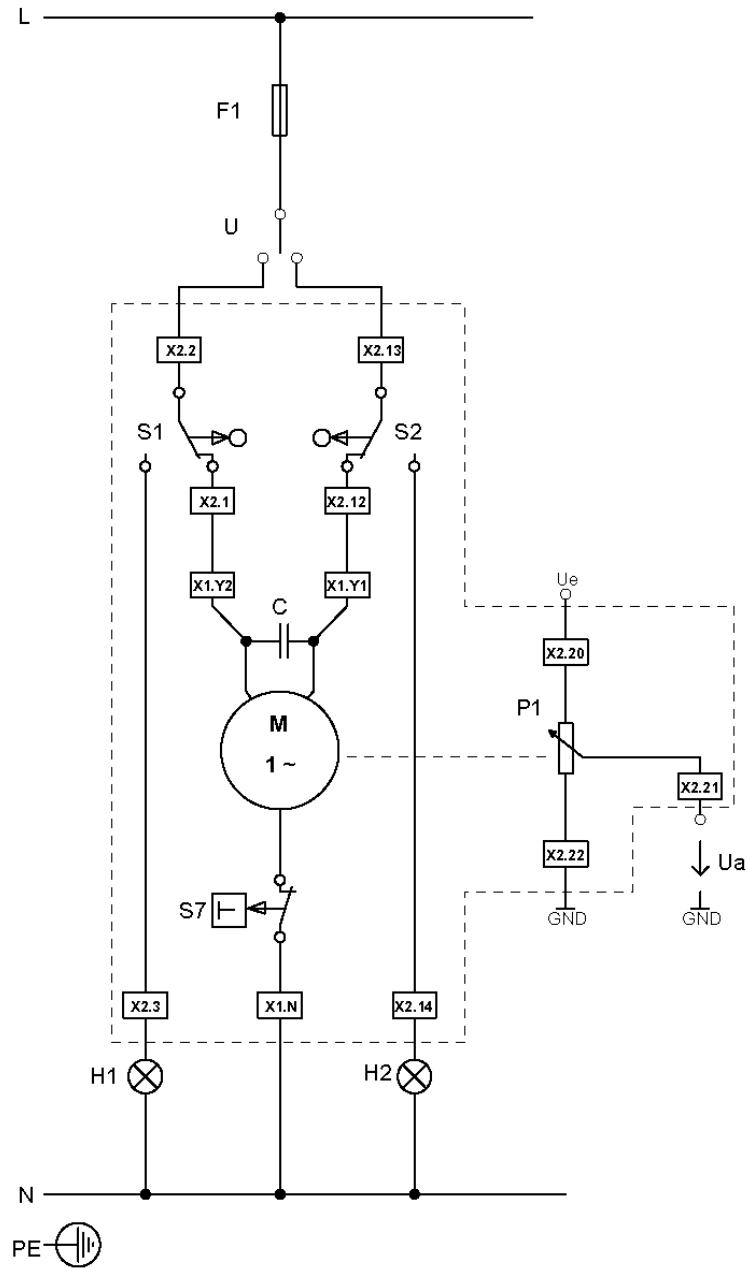

S1 Limit switch CLOSED  
 S2 Limit switch OPEN  
 S7 Thermal switch integrated  
 F1 Fuse  
 H1 Lamp CLOSED  
 H2 Lamp CLOSED  
 C Phase-shift capacitor  
 U Changer  
 P1 Potentiometer

## EBRO ARMATUREN

Suggested wiring diagram for single-phase actuators

**Attention:**  
 The switches are shown inactive.  
 The valve is in intermediate position.



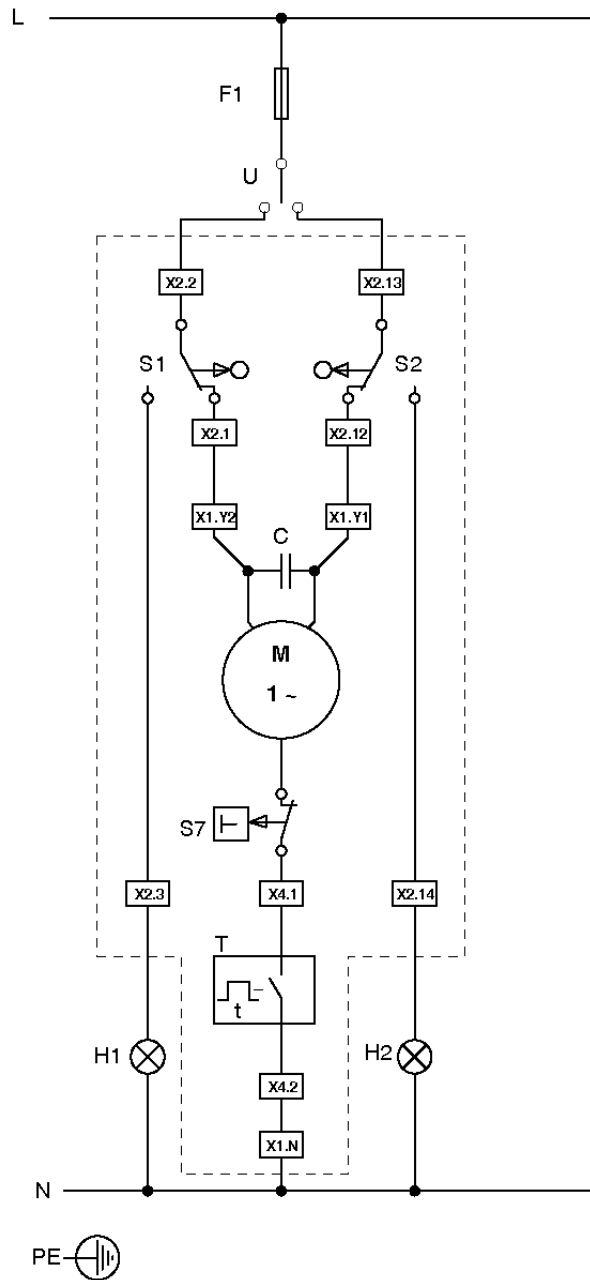

S1 Limit switch CLOSED  
 S2 Limit switch OPEN  
 S7 Thermal switch integrated  
 F1 Fuse  
 U Changer  
 H1 Signal CLOSE  
 H2 Signal OPEN  
 C Phase-shift capacitor  
 T Timer

## EBRO ARMATUREN

Suggested wiring diagram for single-phase actuators with timer

**Attention:**  
 The switches are shown inactive.  
 The valve is in intermediate position.

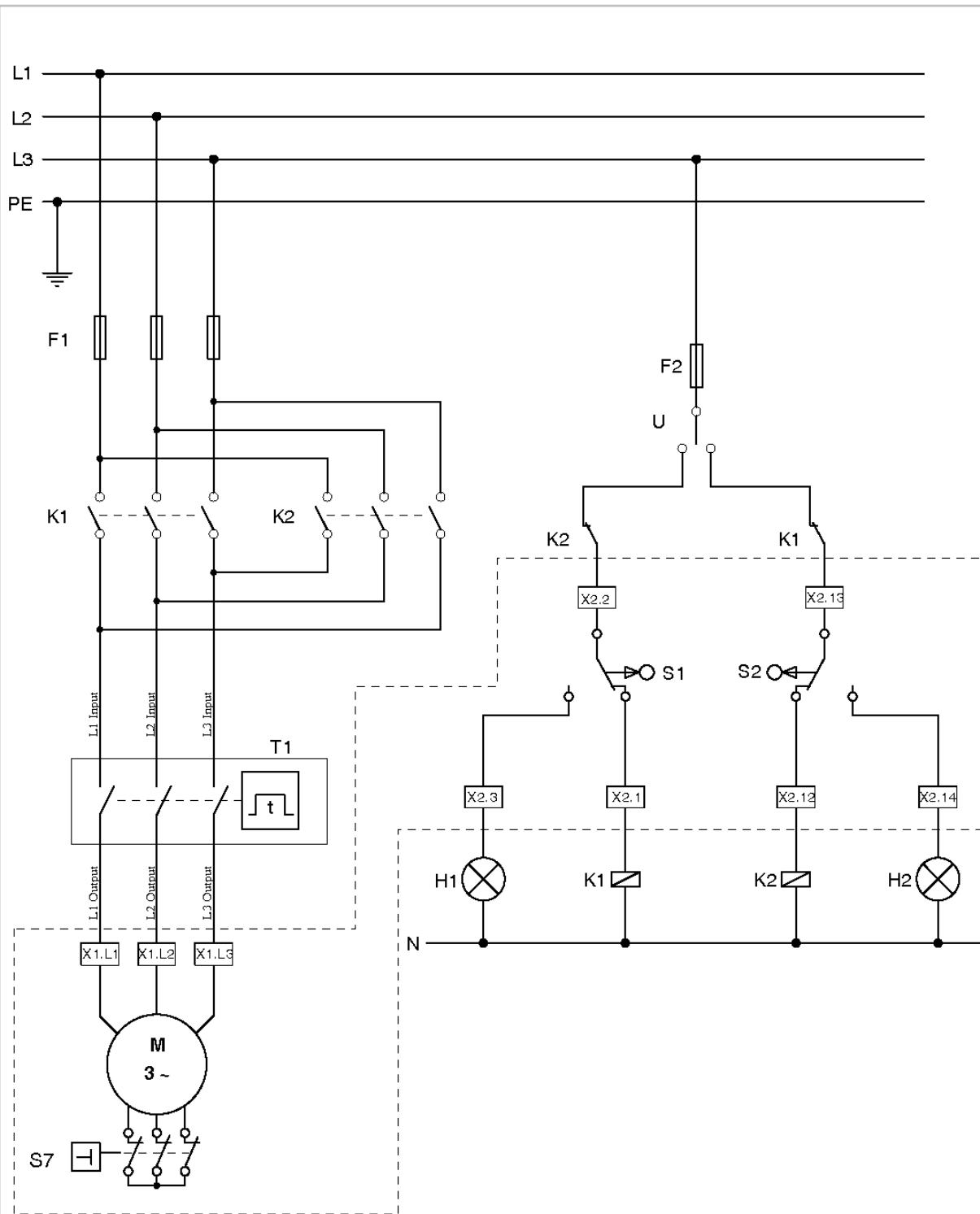

- S1 Limit switch CLOSED
- S2 Limit switch OPEN
- S7 Thermal switch integrated
- U Changer
- K1 Contactor CLOSED
- K2 Contactor OPEN
- H1 Signal CLOSED
- H2 Signal OPEN
- F1 Motor fuses
- F2 Control fuse
- T1 Timer

## EBRO ARMATUREN

Suggested wiring diagram for  
three-phase actuators with timer

**Attention:**  
The switches are shown inactive!  
The valve is in intermediate position.

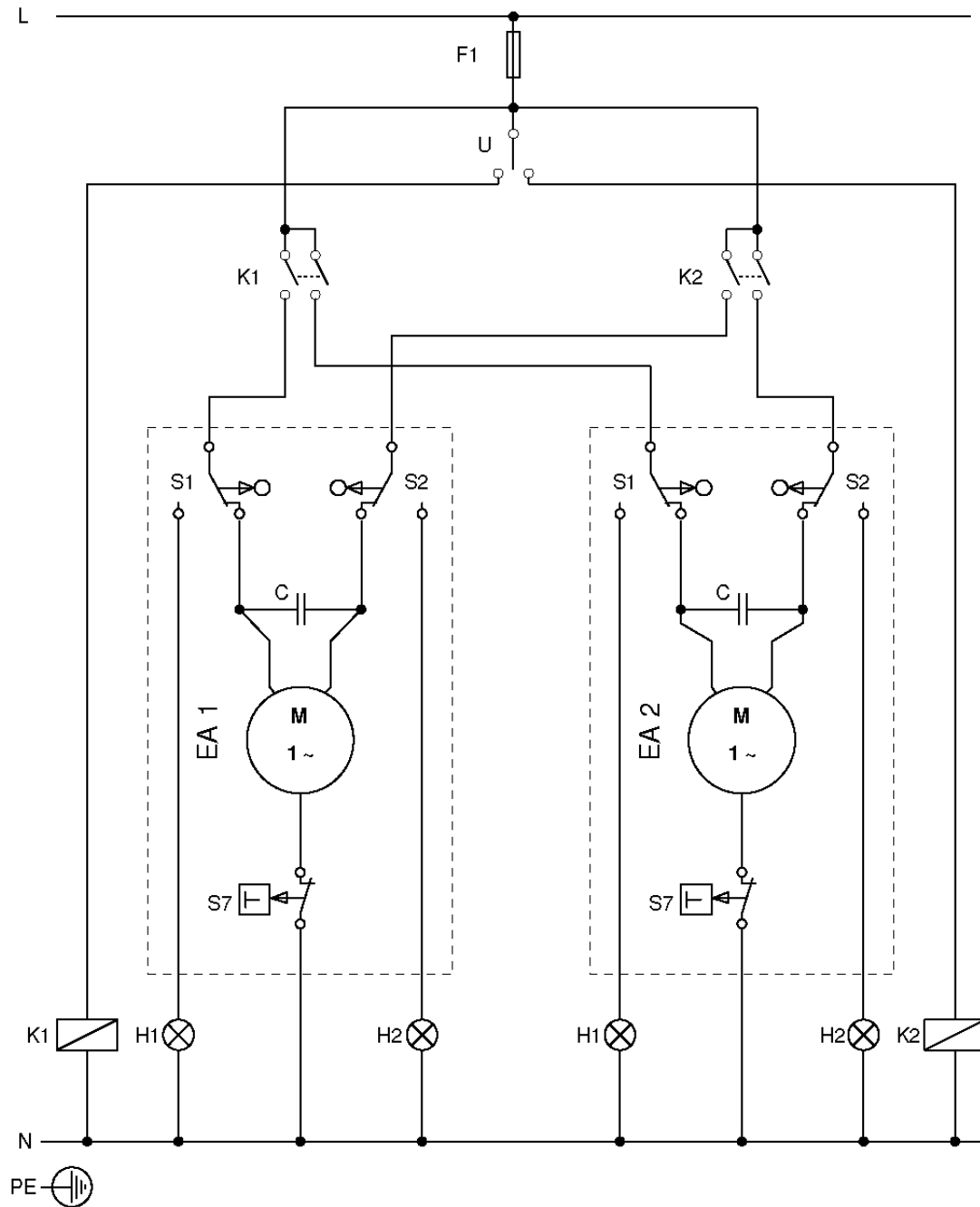

S1 Limit switch CLOSED  
 S2 Limit switch OPEN  
 S7 Thermal switch integrated  
 F1 Fuse  
 H1 Lamp CLOSED  
 H2 Lamp OPEN  
 C Phase-shift capacitors  
 U Changer  
 K1, K2 Control contactors

## EBRO ARMATUREN

Parallel wiring  
of  
single-phase actuators

**Attention:**  
 The switches are shown inactive.  
 The valve is in intermediate position.

## D5 Technical data for actuators, terminal diagrams

### D5-1 Technical features of AC actuators, standard design

#### Common electrical / technical data for all sizes

On-period:	up to max. Class C as per prEN 15714-2
Limit switches:	max. 250V AC, 3A
Torque cut-out:	pot.-free changeover contact, max. 250V AC, 5A (not E50, option for E65)
Switching space heating:	230V AC permanent supply, 5W
Potentiometer:	1000 Ω, 1W, rotation angle 270°
Current feedback:	4-20mA, supply max. 30V DC
Thermostatic switch:	integrated
Insulation class:	F
Corrosion protection class:	C4 as per prEN 15714-2, tested to EN 60068-2-52
Screwed cable glands:	2 x M20x1.5; Ø-min = 6mm; Ø-max. = 13mm
Operation temperature:	-20°C to +70°C
Handwheel:	15 revolutions for 90° <sup>^</sup>
	for E50 -8 Nm for E65 -4Nm, for E110- 20Nm, for E160 -35 Nm, for E210-50Nm

#### Type E50 WS

Nominal voltage	V	230	115*	24*
Actuating time 0°- 90°	s	25	25	25
Rated torque	Nm	40	40	40
Nominal current	A	0.15	0.31	1.45
Starting current	A	0.18	0.36	1.8
Rated input	kW	0.035	0.035	0.035
Frequency	Hz	50	50	50
Weight	kg	4.5		
Flange sizes	F04 and F05 as per EN ISO 5211			
Shaft mountings	for square 11mm, 14mm			

#### Type E65 WS

Nominal voltage	V	230	230	230
Actuating time 0°- 90°	s	6*	12	24*
Rated torque	Nm	100	80	60
Nominal current	A	0.7	0.55	0.3
Starting current	A	1.0	0.8	0.4
Rated input	kW	0.16	0.125	0.066
Frequency	Hz	50	50	50
Weight	kg	7		
Flange sizes	F04 or combined flange F05 and F07 as per EN ISO 5211			
Shaft mountings	for square 10mm, 11mm, 12mm, 14mm, 16mm, 17mm and 16mm with parallel key			

#### Type E110 WS

Nominal voltage	V	230	230	230
Actuating time 0°- 90°	s	6	12*	24*
Rated torque	Nm	400	400	320
Nominal current	A	1.8	1.3	0.65
Starting current	A	2.6	2	1.5
Rated input	kW	0.4	0.26	0.138
Frequency	Hz	50	50	50
Weight	kg	14		
Flange sizes	Combined flange F07 and F10 as per EN ISO 5211			
Shaft mountings	for square 12mm, 14mm, 16mm ,17mm, ,22mm, 24mm and 28mm with parallel key			

**Type E160 WS**

Nominal voltage	V	230	230	230
Actuating time 0°- 90°	s	12*	24	48*
Rated torque	Nm	1200	1200	800
Nominal current	A	1.8	1.3	0.65
Starting current	A	2.6	2	2.5
Rated input	kW	0.4	0.26	0.138
Frequency	Hz	50	50	50
Weight	kg	25		
Flange sizes	F10, F12, F14 und F16 as per EN ISO 5211			
Shaft mountings	for square 22mm, 24mm, 27mm, 32mm and 40mm / 50 mm with parallel key			

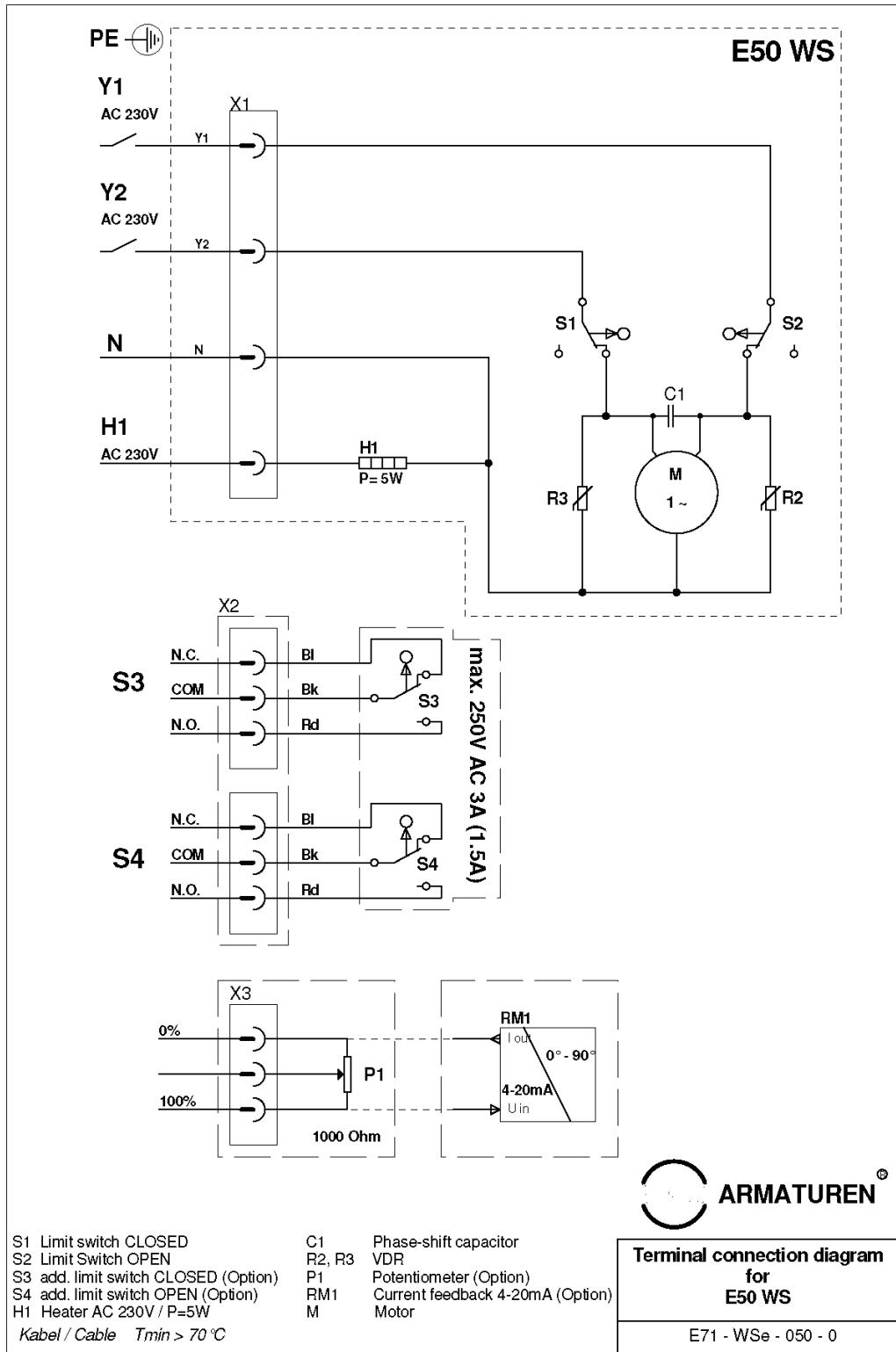

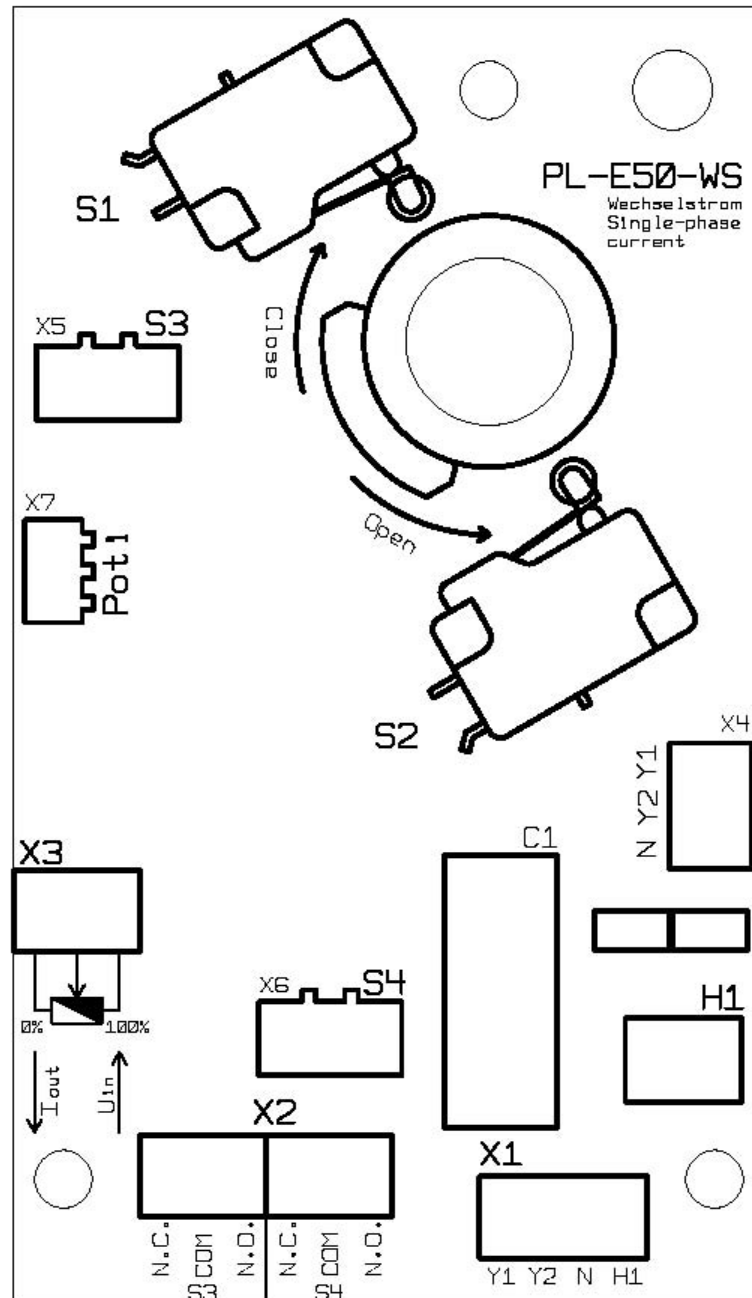

Connection table

Terminal connection	Function
X1.Y1	Motor connection; switched phase for OPEN direction
X1.Y2	Motor connection; switched phase for CLOSED direction
X1.N	Motor connection; neutral conductor
X1.H1	Supply voltage for heating; permanent
X2.S3.nc	Switch S3; additional CLOSED limit switch; break contact; n.c.
X2.S3.com	Switch S3; additional CLOSED limit switch; base contact; com
X2.S3.no	Switch S3; additional CLOSED limit switch; make contact; n.o.
X2.S4.nc	Switch S4; additional OPEN limit switch; break contact; n.c.
X2.S4.com	Switch S4; additional OPEN limit switch; base contact; com
X2.S4.no	Switch S4; additional OPEN limit switch; make contact; n.o.
X3.1	Potentiometer; end contact or current feedback from current output
X3.2	Potentiometer; tap
X3.3	Potentiometer; end contact or current feedback from voltage input

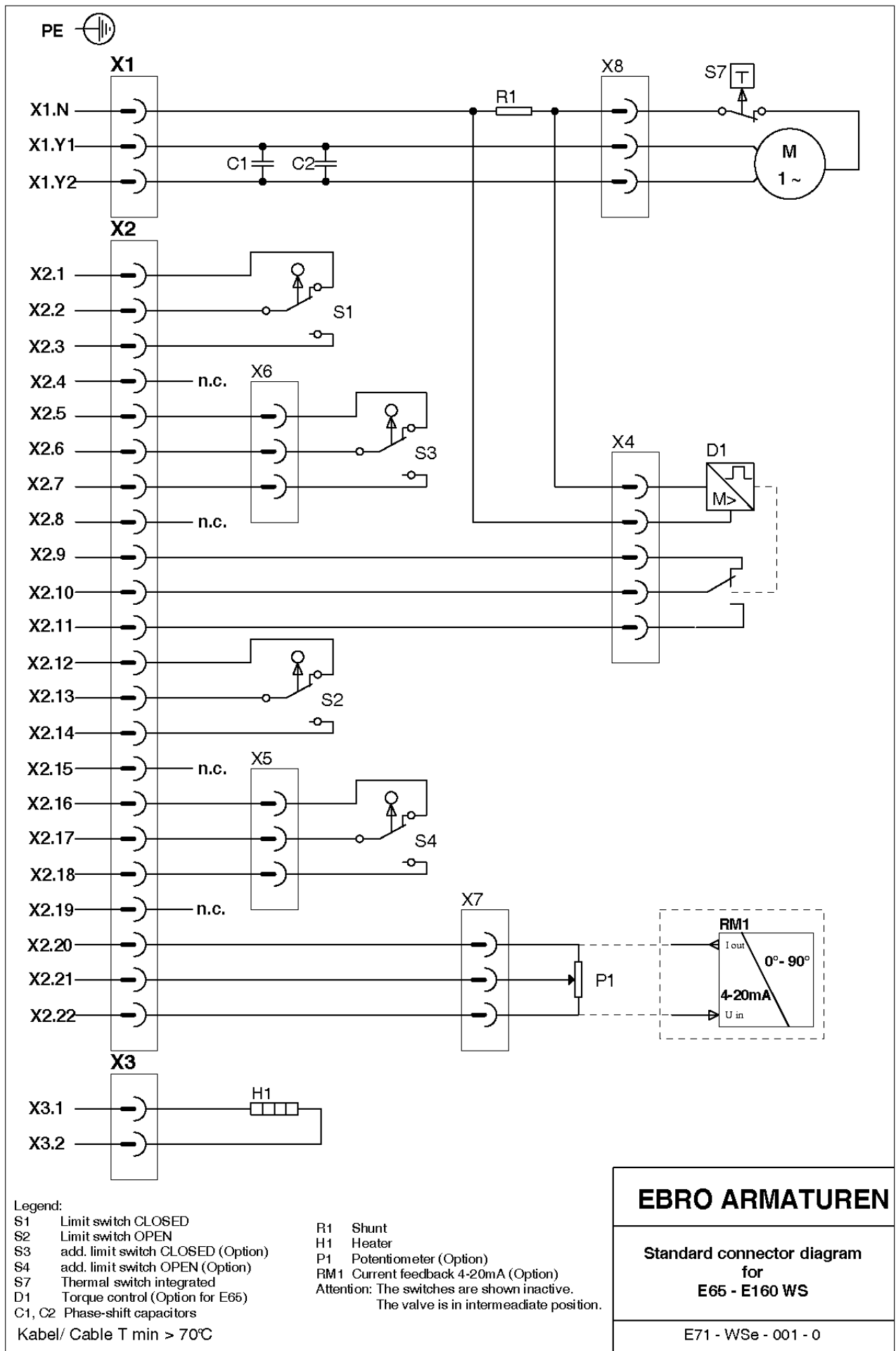

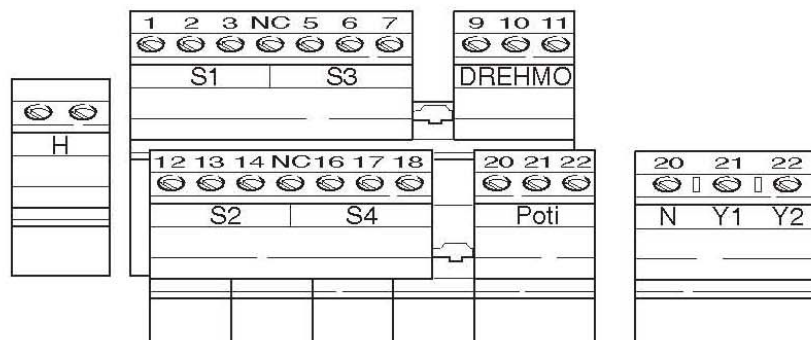
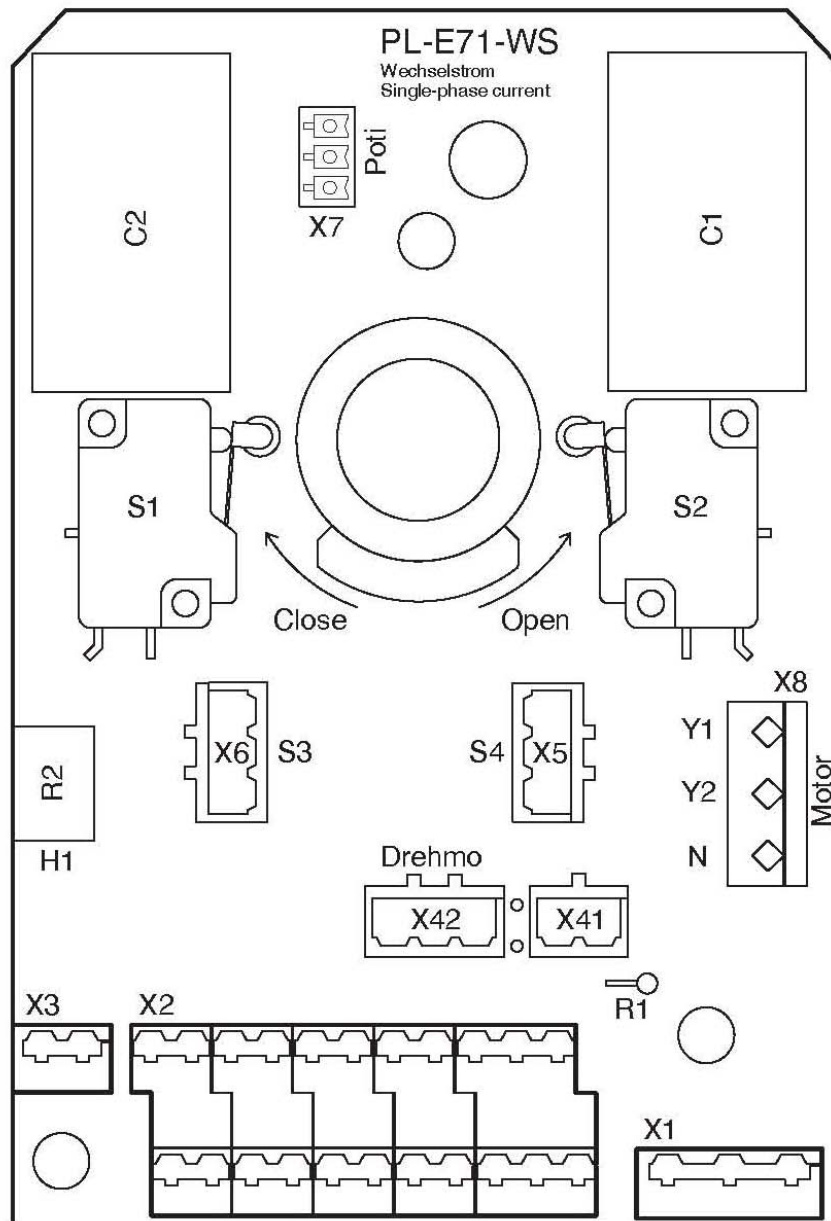

**Connection table**

Terminal connection	Function
X1.N	Neutral conductor
X1.Y1	Motor connection, switched phase for OPEN direction of travel
X1.Y2	Motor connection, switched phase for CLOSED direction of travel
X2.1	Switch S1; CLOSED limit switch; break contact; n.c.
X2.2	Switch S1; CLOSED limit switch; base contact; com
X2.3	Switch S1; CLOSED limit switch; make contact; n.o.
X2.4	Not configured
X2.5	Switch S3; additional CLOSED limit switch; break contact; n.c.
X2.6	Switch S3; additional CLOSED limit switch; base contact; com
X2.7	Switch S3; additional CLOSED limit switch; make contact; n.o.
X2.8	Not configured
X2.9	Torque cut-out, break contact; n.c.
X2.10	Torque cut-out, base contact; com
X2.11	Torque cut-out, make contact; n.o.
X2.12	Switch S2; OPEN limit switch; break contact; n.c.
X2.13	Switch S2; OPEN limit switch; base contact; com
X2.14	Switch S2; OPEN limit switch; make contact; n.o.
X2.15	Not configured
X2.16	Switch S4; additional OPEN limit switch; break contact; n.c.
X2.17	Switch S4; additional OPEN limit switch; base contact; com
X2.18	Switch S4; additional OPEN limit switch; make contact; n.o.
X2.19	Not configured
X2.20	Potentiometer; end contact or current feedback from current output
X2.21	Potentiometer; tap
X2.22	Potentiometer; end contact or current feedback from voltage input
X3.1	Switching space heating; supply voltage 230V permanent
X3.2	Switching space heating; supply voltage 230V permanent

**D5-2 Technical features of three-phase actuators, standard design**

**Common electrical / technical data for all sizes**

On-period:	up to max. Class C as per prEN 15714-2
Limit switches:	max. 250V AC, 3A
Torque cut-out:	potential-free changeover contact, max. 250V AC, 5A (option for E65)
Switching space heating:	230V AC permanent supply, 5W
Potentiometer:	1000 $\Omega$ , 1W, rotation angle 270°
Current feedback:	4-20mA, supply max. 30V DC
Thermostatic switch:	integrated
Insulation class:	F
Corrosion protection class:	C4 as per prEN 15714-2, tested to EN 60068-2-52
Screwed cable glands:	2 x M20x1,5; $\emptyset$ -min = 6mm; $\emptyset$ -max. = 13mm
Operation temperature:	-20°C to +70°C
Handwheel:	15 revolutions for 90° for E65 - 4Nm; for E110 -20 Nm; for E160 -35Nm; for E210 -50Nm

**Type E65 DS**

Nominal voltage	V	400	400	-
Actuating time 0°- 90°	s	6	12*	-
Rated torque	Nm	100	80	-
Nominal current	A	0.3	0.25	-
Starting current	A	0.5	0.3	-
Rated input	kW	0.085	0.065	-
Frequency	Hz	50	50	-
Weight	kg	7		
Flange sizes	F04 or combined flange F05 and F07 as per EN ISO 5211			
Shaft mountings	for square 10mm, 11mm, 12mm ,14mm, 16mm, 17mm and 16 mm with parallel key			

**Type E110 DS**

Nominal voltage	V	400	400	400
Actuating time 0°- 90°	s	6*	12	24*
Rated torque	Nm	400	400	320
Nominal current	A	1.4	1	0.95
Starting current	A	2.1	1.8	1.6
Rated input	kW	0.27	0.22	0.2
Frequency	Hz	50	50	50
Weight	kg	14		
Flange sizes	Combined flange F07 and F10 as per EN ISO 5211			
Shaft mountings	for square 12mm, 14mm ,16mm, 17mm, 22mm, 24mm and 28 mm with parallel key			

**Type E160 DS**

Nominal voltage	V	400	400	400
Actuating time 0°- 90°	s	12*	24	48*
Rated torque	Nm	1000	1000	750
Nominal current	A	1.4	1	0.95
Starting current	A	2.1	1.8	1.6
Rated input	kW	0.27	0.22	0.2
Frequency	Hz	50	50	50
Weight	kg	25		
Flange sizes	F10, F12, F14 and F16 as per EN ISO 5211			
Shaft mountings	for square 22mm, 24mm, 27mm, 32mm and 40mm / 50mm with parallel key			

**Type E210 DS**

Nominal voltage	V	400	400	400
Actuating time 0°- 90°	s	12*	24	48*
Rated torque	Nm	4000	4000	3200
Nominal current	A	3.8	3.2	2.8
Starting current	A	5.6	5.2	3.6
Rated input	kW	1	0.840	0.6
Frequency	Hz	50	50	50
Weight	kg	40		
Flange sizes	F10, F12 and F16 as per EN ISO 5211			
Shaft mountings	for square 27mm, 32mm and 30mm, 40mm / and 50 mm with parallel key			

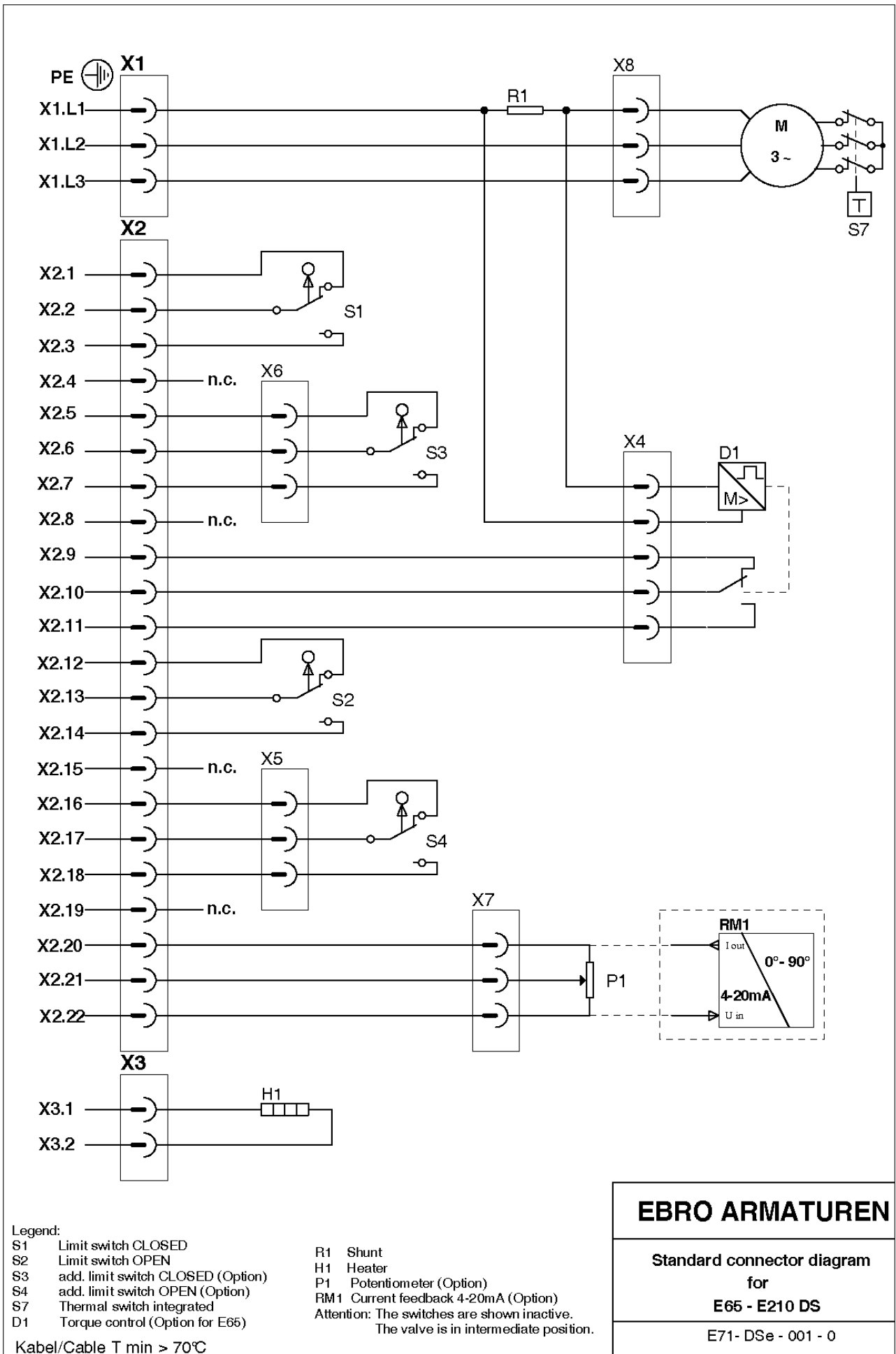



## Connection table

Terminal connection	Function
X1.L1	Motor connection phase
X1.L2	Motor connection phase
X1.L3	Motor connection phase
X2.1	Switch S1; CLOSED limit switch; break contact; n.c.
X2.2	Switch S1; CLOSED limit switch; base contact; com
X2.3	Switch S1; CLOSED limit switch; make contact; n.o.
X2.4	Not configured
X2.5	Switch S3; additional CLOSED limit switch; break contact; n.c.
X2.6	Switch S3; additional CLOSED limit switch; base contact; com
X2.7	Switch S3; additional CLOSED limit switch; make contact; n.o.
X2.8	Not configured
X2.9	Torque cut-out, break contact; n.c.
X2.10	Torque cut-out, base contact; com
X2.11	Torque cut-out, make contact; n.o.
X2.12	Switch S2; OPEN limit switch; break contact; n.c.
X2.13	Switch S2; OPEN limit switch; base contact; com
X2.14	Switch S2; OPEN limit switch; make contact; n.o.
X2.15	Not configured
X2.16	Switch S4; additional OPEN limit switch; break contact; n.c.
X2.17	Switch S4; additional OPEN limit switch; base contact; com
X2.18	Switch S4; additional OPEN limit switch; make contact; n.o.
X2.19	Not configured
X2.20	Potentiometer; end contact or current feedback from current output
X2.21	Potentiometer; tap
X2.22	Potentiometer; end contact or current feedback from voltage input
X3.1	Switching space heating; supply voltage 230V permanent
X3.2	Switching space heating; supply voltage 230V permanent

### D5-3 Technical features of DC actuators, standard design

#### Common electrical / technical data for all sizes

On-period:	up to max. Class C as per prEN 15714-2
Limit switches:	max. 24V DC, 10A
Switching space heating:	24V DC permanent supply, 5W
Potentiometer:	1000 $\Omega$ , 1W, rotation angle 270°
Current feedback:	4-20mA, supply max. 30V DC
Motor protection:	thermal overcurrent switch; alarm relay Re2 = 24V / 3A
Insulation class:	F
Corrosion protection class:	C4 as per prEN 15714-2, tested to EN 60068-2-52
Screwed cable glands:	2 x M20x1,5; $\emptyset$ -min = 6mm; $\emptyset$ -max. = 13mm
Operation temperature:	-20°C to +70°C
Handwheel:	15 revolutions for 90° 4 Nm for E65, /20Nm for E110, 35 Nm for E160

**Type E65 GS**

Nominal voltage	V	24		
Actuating time 0°- 90°	s	6 *)		
Rated torque	Nm	100		
Nominal current	A	5.5		
Starting current	A	8		
Rated input	kW	0.077		
Frequency	Hz	-		
Weight	kg	7		
Flange sizes	F04 or combined flange F05 and F07 as per EN ISO 5211			
Shaft mountings	for square 10mm, 11mm, 12mm, 14mm, 16mm, 17mm and 16mm with parallel key			

**Type E110 GS**

Nominal voltage	V	24		
Actuating time 0°- 90°	s	6 *)		
Rated torque	Nm	360		
Nominal current	A	8.8		
Starting current	A	12.5		
Rated input	kW	0.4		
Frequency	Hz	-		
Weight	kg	14		
Flange sizes	Combined flange F07 and F10 as per EN ISO 5211			
Shaft mountings	for square 12mm, 14mm ,16mm, 17mm , 22mm, 24mm and 28mm with parallel key			

**Type E160 GS**

Nominal voltage	V	24		
Actuating time 0°- 90°	s	12 *)		
Rated torque	Nm	800		
Nominal current	A	8.8		
Starting current	A	12.5		
Rated input	kW	0.4		
Frequency	Hz	-		
Weight	kg	25		
Flange sizes	F10, F12, F14 and F16 as per EN ISO 5211			
Shaft mountings	for square 22mm, 24mm, 27mm, 32mm and 40mm / 50mm with parallel key			

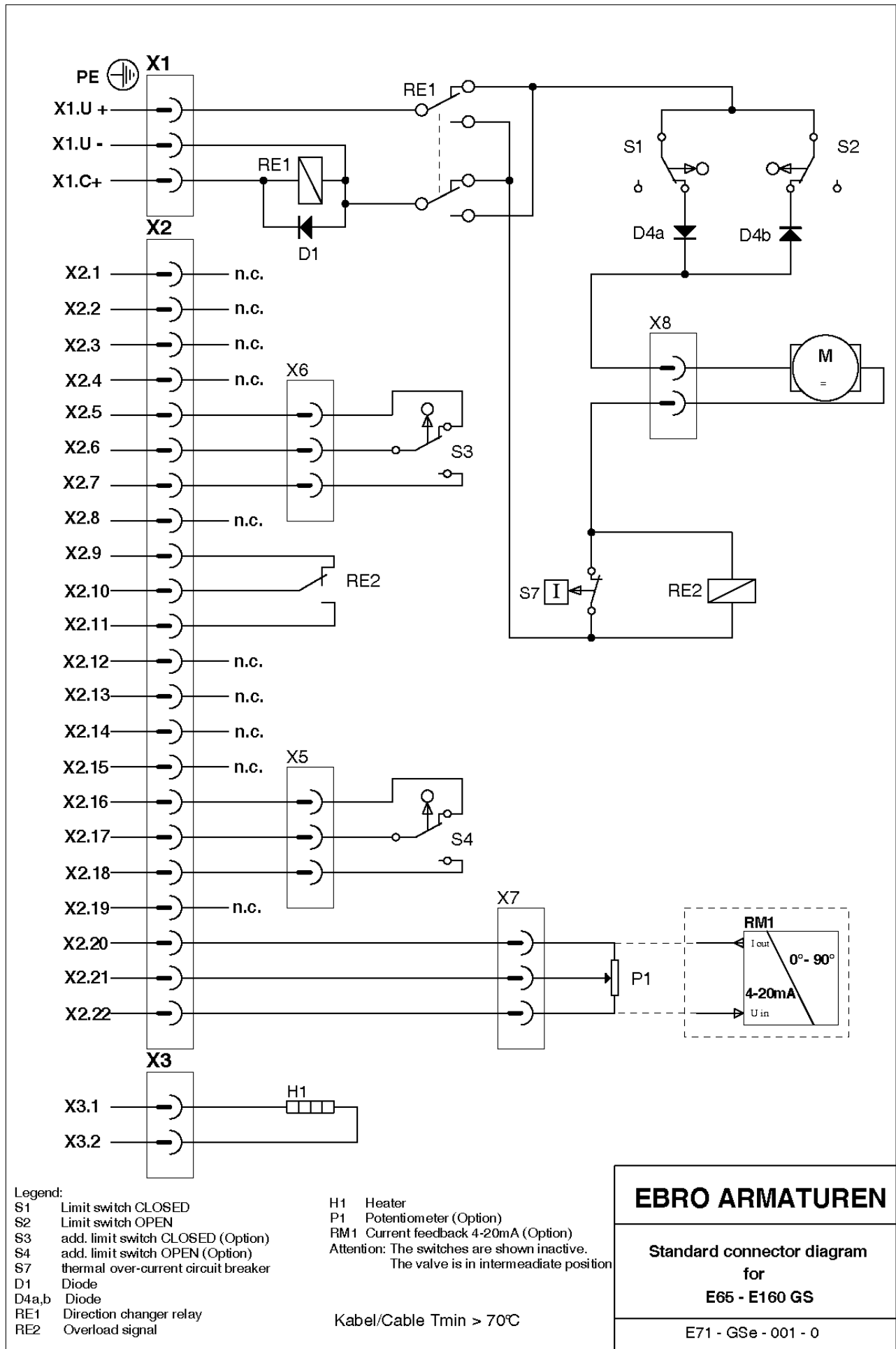

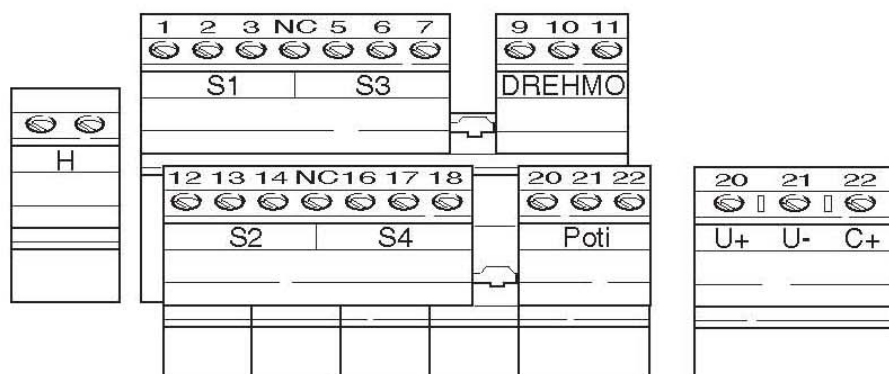
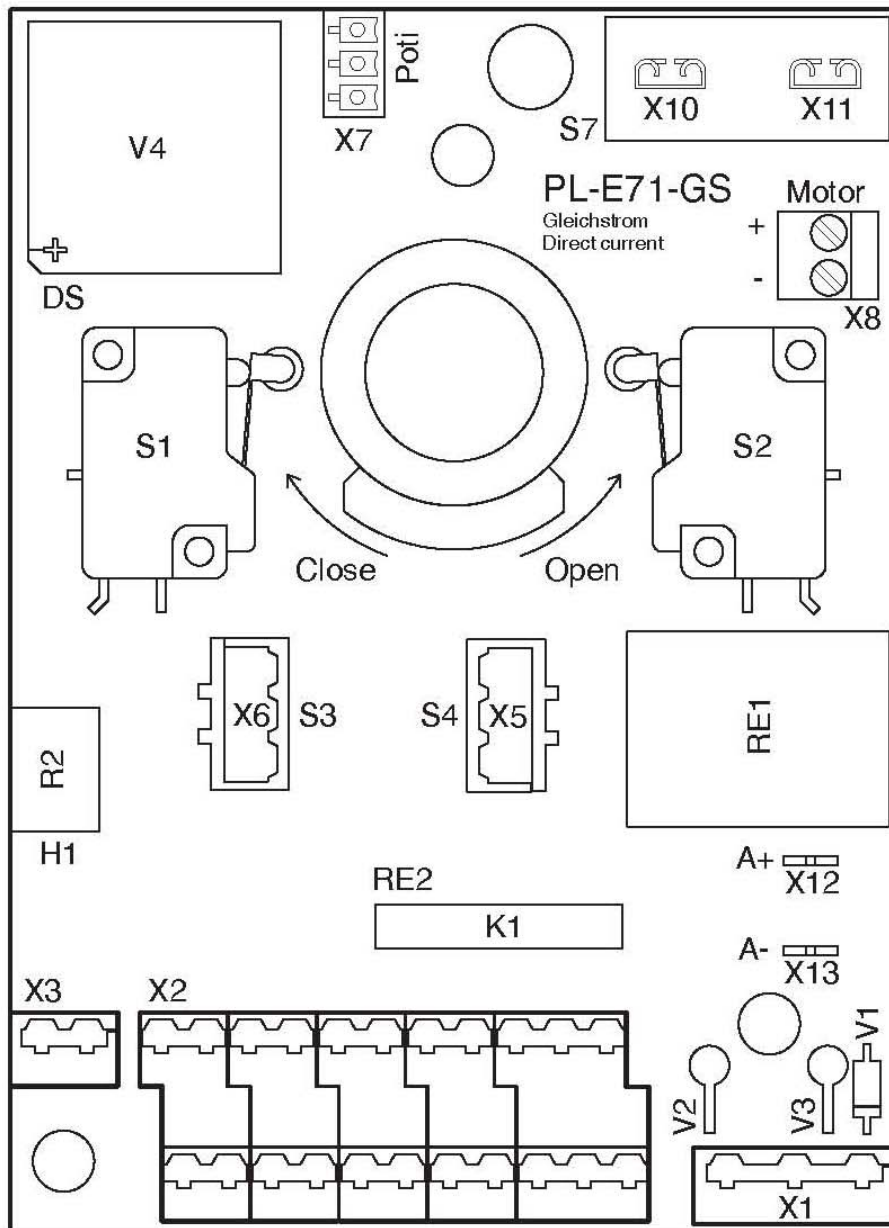

**Connection table**

Terminal connection	Function
X1.U +	Supply voltage 24V DC plus, permanent
X1.U -	Supply voltage 24V DC minus, permanent
X1.C+	Control input for reversing relay + 24V DC
X2.1	Not configured
X2.2	Not configured
X2.3	Not configured
X2.4	Not configured
X2.5	Switch S3; additional CLOSED limit switch; break contact; n.c.
X2.6	Switch S3; additional CLOSED limit switch; base contact; com
X2.7	Switch S3; additional CLOSED limit switch; make contact; n.o.
X2.8	Not configured
X2.9	Alarm relay, overcurrent tripping; break contact; n.c.
X2.10	Alarm relay, overcurrent tripping; base contact; com
X2.11	Alarm relay, overcurrent tripping; make contact; n.o.
X2.12	Not configured
X2.13	Not configured
X2.14	Not configured
X2.15	Not configured
X2.16	Switch S4; additional OPEN limit switch; break contact; n.c.
X2.17	Switch S4; additional OPEN limit switch; base contact; com
X2.18	Switch S4; additional OPEN limit switch; make contact; n.o.
X2.19	Not configured
X2.20	Potentiometer; end contact or current feedback from current output
X2.21	Potentiometer; tap
X2.22	Potentiometer; end contact or current feedback from voltage input
X3.1	Switching space heating; supply voltage 24V permanent
X3.2	Switching space heating; supply voltage 24V permanent

**D6 Notes on user risk analysis**

	<p>The following sections D6.1 to D6.4 are safety instructions relating to various risks based on the manufacturer's risk analysis for intended use of these quarter turn actuators in normal industrial applications, and are designed to be integrated into the user risk analysis.</p> <p>The planner/operator is responsible for supplementing this information for system-specific risks if necessary</p>
---	--

**Compliance with the <intended use> – see section A2 – is a prerequisite for preventing risks during use of the actuator.**

**D6-1 Notes on analysis of the risk from supply and control voltage**

**The permissible voltage for the motor is specified on the actuator typeplate; overvoltages of up to 10% of the nominal voltage are permitted. A sample typeplate is shown in chap. A4.**

All parts of the actuator that are energized must be covered during normal use (IP67, EN 60529) and cable inlets must be sealed with screwed cable glands.

 <b>Warning!</b>	The switching space cover may only be opened when all motor and control voltages are switched off.
--	--

Cable inlets must also be protected from tensile and similar loads during continuous operation – also to prevent consequential short-circuit in the actuator.

**D6-2 Notes on analysis of the risk from moving parts**

**The revolving handwheel does not represent any risk for the user in accordance with MD and EN15714-2. It can be used to operate the valve at any time during non-electrical operation, but must not be locked when the actuator is operating.**

**All other moving parts of the actuator are covered:**

- ▶ either by the actuator housing,
- ▶ or by the valve/actuator interface as per ISO 5211.

 <b>Warning!</b>	However, to avert the risk of becoming caught between the valve shut-off device (flap, ball) and its housing, a mounted actuator may only be put into operation if the valve is permanently installed between pipe sections on both sides.
--	--

**The actuator is screwed to the valve in the interface as per ISO5211. Section B3 contains the necessary tightening torques for the screw connection.**

**Secure fitting of this screw connection must be monitored by means of visual inspection at appropriate intervals (during valve maintenance at the latest) on actuators with a higher operating frequency, and the connection tightened if required.**

**D6-3 Notes on risks from continuous operation**

**The actuator is designed in accordance with EN15714-2, Table 1 for Class C.**

Quarter turn actuators E50 to E210 fulfil the on-period of Class C as per EN 15714-2.

Classes A and B are covered by Class C.



The following applies for Class C:

- Type E50, E65 max. 1200 start-ups per hour,
- Type E110 max. 600 start-ups per hour,
- Type E160 max. 600 start-ups per hour,
- Type E210 max. 300 start-ups per hour.

For an ambient temperature <40°C, the switch-on frequency must be reduced by approx. 10%.

**The windings of all motors are thermally protected and are switched off automatically in the event of overheating. DC actuators (type E□□GS) have a thermal overcurrent switch for motor protection, which must be reset manually after triggering.**

The material selection and manufacturing tolerances of the valve drive shaft interface must be adapted to the frequency of the switching operations by the valve manufacturer in accordance with the requirements of EN 5211.

	<p>The EBRO standard design in the actuator is either a square or a cylindrical bore with parallel key as per DIN 6885</p>
	<p>The &lt;CLOSED&gt; position of the valve has been adjusted when mounting the actuator. As long as the valve is tight, this setting should not be changed. If readjustment is necessary, detailed information is provided in the EBRO Mounting Instructions <b>MA4.4-MD Section 2.2</b> and/or the relevant valve manual.</p>

#### D6-4 Notes on other risks

Actuating times:

The actuator has a defined actuating time for the full turn of 90° – see Technical Appendix. In order to increase the total actuating time, an electronic actuating time extension is optionally available for DC and AC actuators: this can also be retrofitted.

For this purpose the motor is electronically synchronized and generates a turn of 1°- 2° at the valve disk. This is followed by a pause until the next pulse. This pause can be adapted to the system conditions using a potentiometer.

Retrofitting with electrical (electronic) components:

If an actuator's control board is to be upgraded due to special operating conditions, the data on the typeplate must be specified when ordering the required components from EBRO-Armaturen. Replacement instructions will also be supplied.

**Mechanical loads:**

- ▶ **External loads must be kept away from valve, actuator and feed lines.**
- ▶ **The actuator is designed for a static load in the pipe system. Risks arising from loads caused by vibrations in the system are not covered: in such cases, the long-term protection of the screw connections on the actuator must at least be agreed with the manufacturer EBRO-Armaturen.**

**Low / high temperatures:**

The standard actuator is designed for operating temperatures below 70°C and above - 20°C – outside this range, seals and lubricants in the actuator and consequently the functions will be negatively affected:

The actuator motor generates heat: if this results in a surface temperature higher than 40°C on the outside of the motor, any cover required on the system-side to protect personnel is not the responsibility of the manufacturer EBRO-Armaturen and is not included in the scope of supply.

 <b>Warning!</b>	<p>This cover must not significantly impede the heat emission from the motor, in order to avoid overheating of the motor windings and associated faults. Consult EBRO-Armaturen if necessary.</p>
--	---

**Corrosion protection of external surfaces:**

The actuator is supplied as standard with corrosion protection as per EN60068 (corresponds to Cat. C as per EN15714-2) (also see D2.9).

If this is inadequate for the ambient conditions, appropriate protective measures should be agreed with EBRO-Armaturen.

**Environmental protection:**

The actuator contains lubricating grease in its gear mechanism, but this is fully encapsulated and does not emit any hazardous substances for the purposes of Appendix I, 1.5.14 of MD.

**D7 Order code for spare parts and additional assemblies**

The modular design of EBRO actuators allows simple retrofitting of your standard actuator for special functions and trouble-free replacement of defective electrical assemblies.

Installation instructions are supplied with the delivery.

Assembly	Selection criteria depending on		
	Actuator type/size	Voltage type	Actuating time
01 = Motor	X	X	X
02 = Handwheel	X		
03 = Shaft mounting	X		
04 = Operating cam			
05 = Seal set	X		
06 = Main board	X	X	
07 = Additional limit switches			
08 = Torque cut-out	X	X	X
09 = Potentiometer			
10 = Current feedback			
11 = Actuating time extension		X	
	<i>X: Data on typeplate must be specified for subsequent orders</i>		

**Spare parts: EST order code**

	Size	Voltage	Assembly	Actuating time	Consecutive number
<b>EST-</b>	YYY	YYY	YY	YY	YYYY

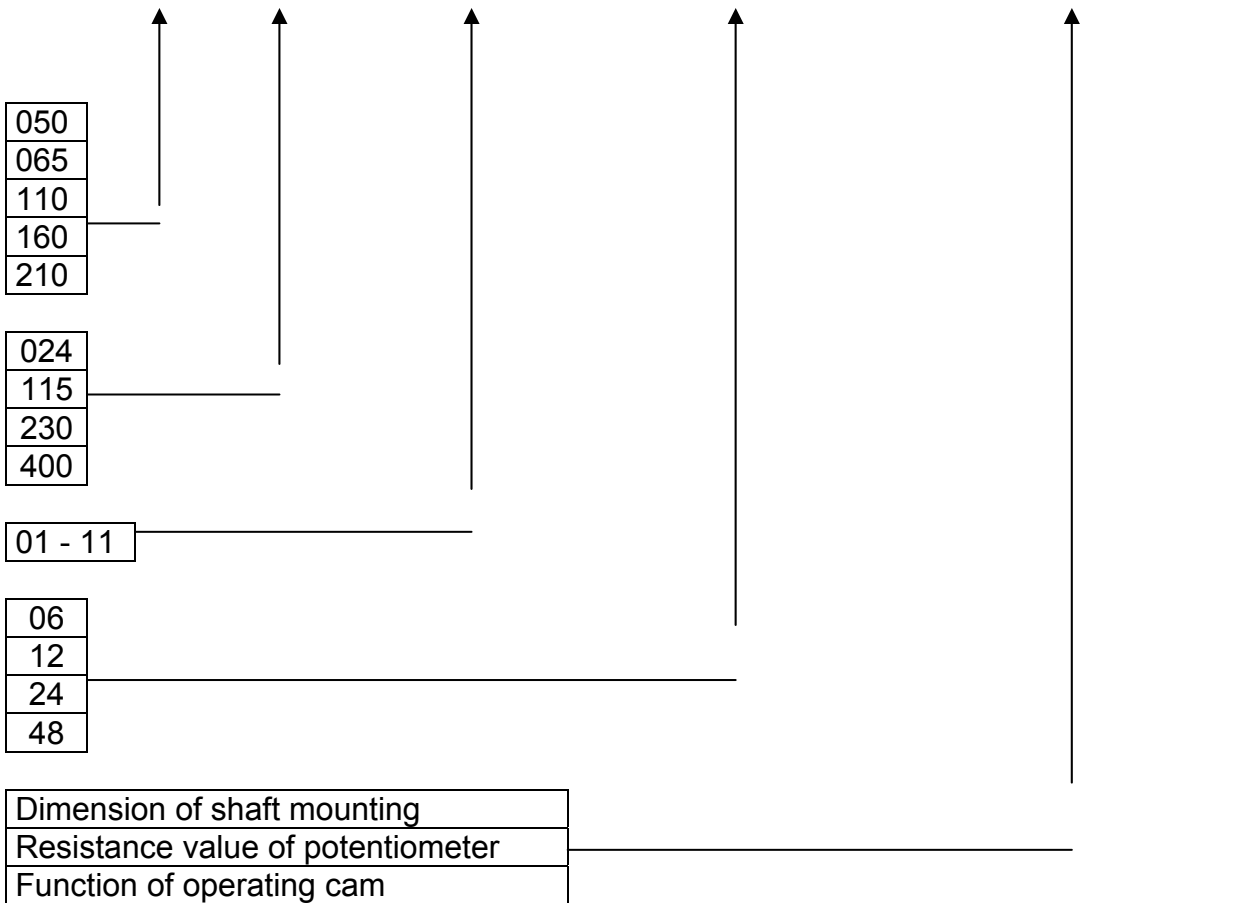

**Example:**

**EST-110-230-08-12-0000**

Torque cut-out for E110 WS with 12s actuating time

## EC Declaration of Conformity

We,

### **EBRO Armaturen**

**Gebr. Bröer GmbH  
Karlstrasse 8  
58135 Hagen  
Deutschland**

declare, under our sole responsibility, that the E-Series of electrical quarter turn actuators

<b>E50 WS</b>	<b>E 65 WS</b>	<b>E 110 WS</b>	<b>E 160 WS</b>	
	<b>E 65 DS</b>	<b>E 110 DS</b>	<b>E 160 DS</b>	<b>E 210 DS</b>
	<b>E 65 GS</b>	<b>E 110 GS</b>	<b>E 160 GS</b>	

and their mounting modules

**M71-WS-XXX-40 and M71-DS-XXX-40 and M71-GS-XXX-40**

to which this declaration refers, meet the requirements of the following directives of the Council for Harmonization of Regulations of the Member States:

<b>Directive - 2006/95/EC -</b>	<b>Low Voltage Directive</b>
<b>Directive - 2004/108/EC -</b>	<b>Electromagnetic Compatibility</b>
<b>Directive - 2006/42/EC -</b>	<b>Machinery Directive *</b>

(\* Electrical actuators are considered "incomplete machines" for the purposes of the Machinery Directive in accordance with article 2g)

As manufacturer of these products, we additionally declare that the following standards have been used for assessment, in accordance with the abovementioned directives.

**EN 50178 : 1997**  
**EN 61010 -1 : 2002**                      **for the Low Voltage Directive (LVD)**

**EN 55011 : 2007**  
**EN 61000**                                      **for Electromagnetic Compatibility (EMC)**

**EN ISO 5211**  
**prEN 12100**                                      **for the Machinery Directive (MD)**  
**EN IEC 60529**

The member of staff responsible for the documented and required analyses is Mr. V. Pütz at EBRO ARMATUREN.

Commissioning is forbidden until it has been ensured that the complete machine, in which the EBRO quarter turn actuators - or with valve – are mounted or installed, comply with the regulations of EC directive 2006/42/EC.

Hagen, 4.12.2009

  
\_\_\_\_\_  
Dirk Mischnick, Managing Director

<b>The manufacturer</b>	<b>EBRO ARMATUREN Gebr. Bröer GmbH, D58135 Hagen</b>
declares that the EBRO electrical quarter turn actuators "Type E50 to E210" complies with the following provisions	
<b>Requirements according to Annex I of the Machinery Directive 2006/42/EC</b>	
1.1.1, g) Intended use	Original Mounting Instructions with Operating Instructions
1.1.2.,c) Warnings against misuse	Original Mounting Instructions with Operating Instructions
1.1.2.,c) Protective equipment required	Exactly as for the system in which the actuator is installed
1.1.2.,e) Accessories	No special tool required for replacing wearing parts
1.1.5 Handling	Fulfilled by Original Mounting Instructions with Operating Instructions
1.2 and 6.2.11 Control	Under the user's responsibility, in coordination with the Operating Instructions for the actuator
1.3.4 Sharp corners and edges	Requirement fulfilled
1.3.7/8 Injury from moving parts	Requirement fulfilled with intended use. Maintenance and repair are only permitted when the actuator is stationary and the energy supply switched off
1.5.1 – 1.5.3 Energy supply	Under the user's responsibility. Also see Operating Instructions for the actuator
1.5.5. Operating temperature	Warning against unacceptable exceeding: see Operating Instructions, section <Warnings>
1.5.7 -Explosion	Not applicable
1.5.13 Emission of hazardous substances	Not applicable, provided the actuator is operated as intended
1.6.1 Maintenance	Maintenance-free with normal use.
1.7.3 Identification	On the typeplate; see Original Mounting Instructions with Operating Instructions
1.7.4 Operating instructions	Requirement fulfilled
Requirement acc. to Appendix III	The actuator is not a <complete machine>: therefore no EC marking for conformity as per Machinery Directive
Requirements acc. to App. IV, VIII-XI	Not applicable
Requirements as per prEN 12100:2009	
1. Field of application	Product standard prEN 15714-2:<Electrical quarter turn actuators for industrial valves> with an actuator as per EN15714-2 was used as basis for the analysis. Basis is also the >10 years of experience using the abovementioned actuator types. <i>Note: It must be assumed that the planner/operator will perform a risk analysis for the pipe section including the actuators used in it, specifically tailored to the operating case, in accordance with sections 4 to 6 of EN 12100 – such an analysis is not possible for the manufacturer EBRO-ARMATUREN in the case of standard actuators.</i>
3.20, 6.1 Inherently safe design	The actuators are manufactured in accordance with the principle of <inherently safe design>.
Analysis in accordance with sections 4, 5 and 6	Experiences of malfunctions and misuse documented by the manufacturer within the scope of cases of damage (documentation according to ISO9001) have been used as the basis.
5.3 Limits of the machine	The demarcation of the <incomplete machine> has been made on the basis of the <intended use> of both valve and actuator.
5.4 Decommissioning, disposal	Not in the manufacturer's area of responsibility.
6.2.2 Geometrical factors	As valve and actuator enclose the functional parts of the actuator during intended use, this section is not applicable.
6.3 Technical protective devices	None, in compliance with the valid VDE regulations and the instructions from the Original Mounting Instructions with Operating Instructions.
6.4.5 Operating instructions	As valves with actuators operate "automatically" according to the commands of the control, the operating instructions describe those aspects that are <actuator-typical> and must be made available to the manufacturer of the (pipe) system.
7 Risk analysis	The risk analysis performed has been carried out in accordance with MD Appendix VII, B) by the manufacturer EBRO Armaturen and is documented in accordance with MD Appendix VII B).