

Pneumatic Quarter Turn Actuators

Type EB4 - EB12 SYD double-acting

Type EB5 - EB12 SYS single-acting

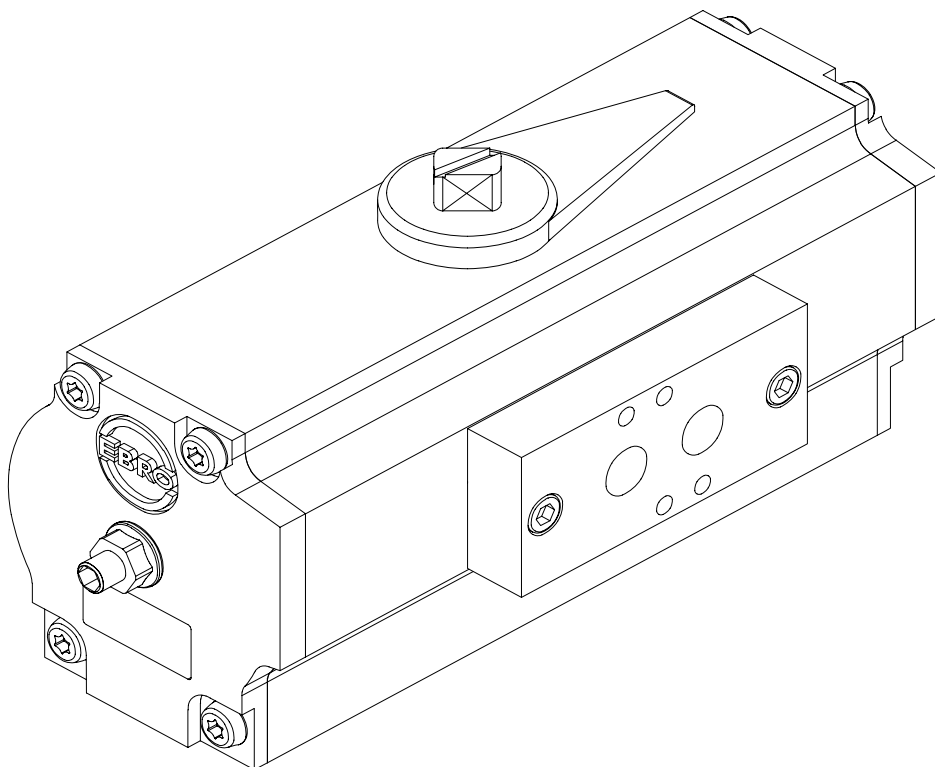

Mounting Instructions

With Operating Manual and Technical Appendix

in accordance with EC Machinery Directive 2006/42/EC

English Version

Contents

	Page
A) GENERAL	3
A1 EXPLANATION OF SYMBOLS	3
A2 INTENDED USE	3
A3 DIVERGENT USE	4
A4 IDENTIFICATION OF THE ACTUATOR	4
A5 TRANSPORT AND (INTERMEDIATE) STORAGE	4
B) MOUNTING THE ACTUATOR TO THE VALVE AND CONNECTION OF ADDITIONAL ASSEMBLIES	5
B1 SAFETY INSTRUCTIONS FOR MOUNTING AND CONNECTION	5
B2 INTERFACES	5
B3 INDIVIDUALLY SUPPLIED ACTUATOR MOUNTING ON THE VALVE	6
B4 ALL ACTUATORS: CONNECTION TO THE COMPRESSED AIR SUPPLY	6
B5 IF REQUIRED: CONNECTION OF ADDITIONAL ELECTRICAL/PNEUMATIC ASSEMBLIES TO THE CONTROL	7
B6 ALL ACTUATORS: ADJUSTMENT OF THE NORMAL <CLOSED> POSITION	8
B7 ALL ACTUATORS TRIAL RUN: TEST STEPS TO CONCLUDE MOUNTING AND CONNECTION	8
B8 ADDITIONAL INFORMATION: DEMOUNTING THE ACTUATOR	9
C) OPERATING INSTRUCTIONS	10
C1 SAFETY INSTRUCTIONS FOR OPERATION	10
C2 AUTOMATIC OPERATION / MANUAL OPERATION	10
C3 TROUBLESHOOTING	10
D) TECHNICAL APPENDIX / PLANNING DOCUMENTS	12
D1 STANDARD ACTUATOR DESIGN	12
D1-1 ADAPTATION TO THE VALVE	12
D1-2 OUTPUT TORQUES OF THE ACTUATORS	12
D1-3 ROTATIONAL DIRECTION OF THE ACTUATOR	12
D1-4 VALVE ASSIGNMENT	12
D1-5 SELF-LOCKING WHEN STATIONARY	12
D1-6 SERVICE LIFE	13
D1-7 MANUAL OVERRIDE	13
D1-8 INSTALLATION POSITION	13
D1-9 CORROSION PROTECTION	13
D2 OPTIONAL ADDITIONAL EQUIPMENT	13
D2-1 SOLENOID VALVE	13
D2-2 LIMIT SWITCHES (FOR POSITION DETECTION)	13
D2-3 MANUAL OVERRIDE (WITH ADDITIONAL GEAR)	13

**MOUNTING INSTRUCTION FOR PNEUMATIC QUARTER TURN ACTUATORS
EB4 – EB12 SYD AND EB5 – EB12 SYS**

D4	NOTES ON RISKS ARISING FROM CONTINUOUS OPERATION	15
D5	NOTES ON OTHER RISKS	15
<u>DECLARATION IN ACCORDANCE WITH EC DIRECTIVES</u>		<u>16</u>

You can find additional information and current addresses of our branches and trade partners at:

www.ebro-armaturen.com

EBRO Armaturen International Est.+ Co.KG

Gewerbstrasse 5

CH-6330 Cham



☎ (041) 748 5959

Fax (041) 748 5999

A) General

A1 Explanation of symbols

Notes are denoted by the following symbols in this Operating Manual:

 xxxxxxx	Danger / Warning ... indicates an immediately hazardous situation, which can result in death or severe injuries if not avoided.
	Note ... indicates an instruction that must be complied with.
	Information ... provides useful tips and recommendations

A2 Intended use

Pneumatic quarter turn actuators of type EB SYD (double-acting) and type EB SYS (with opening or return spring) are intended for use as follows,

- after connection of the solenoid valve to a system-side control,
- with gaseous control medium (generally compressed air) with control pressure according to typeplate,
- in ambient conditions between -20°C and +80°C (EBRO standard),
or between -40°C and +140°C (EBRO special designs)
- spring-closing or spring-opening for type EB SYD with double-acting function, for type EB SYS with "fail safe" function,
- for actuating valves with 90° turn (e.g. flap valves and ball valves) into <OPEN> and <CLOSED> positions, with the electrical signals of the abovementioned control.
- A correctly connected actuator must generally close in a clockwise direction (looking at the valve drive shaft) and open anticlockwise.

The output torque and characteristic curve of the actuator – see Technical Appendix – must be adapted to the valve, and its optical display must correctly indicate the position of the valve.

The compressed air must be filtered with a mesh size of 40µm, in order to protect the solenoid valve (ISO 8573-1, Class 5). It must be dried and also lightly oiled for switching cycles >4x/min.

An (optional) "position indicator" assembly installed on the actuator serves to indicate the actuator position to the system-side control.

An (optional) "position encoder" assembly installed on the actuator serves to also move to intermediate valve positions between <OPEN> and <CLOSED> and to indicate these to the system-side control.

The actuator may only be commissioned after noting the following documents:

- The <Manufacturer's declarations regarding EC directives> enclosed with the delivery
- This EBRO Installation Manual **MA4.0 – MRL** (enclosed with the delivery).

The safety instructions in sections B1 and C1 must be observed for mounting and operation of the actuator.

MOUNTING INSTRUCTION FOR PNEUMATIC QUARTER TURN ACTUATORS

EB4 – EB12 SYD AND EB5 – EB12 SYS

	Which connection diagram is used depends on the intended use of the valve and – for actuators with "fail safe" function – on the type of spring provided in the actuator: this must be decided and selected accordingly by the planner/purchaser of the actuator. For application-typical connection diagrams see section B4.
---	--

Note 1:

These instructions apply primarily in conjunction with the instructions for the valve to which the actuator is mounted; the instructions for this valve **take precedence**.

Note 2:

The purchaser is responsible for allocation of an individually supplied actuator to the valve. Appendix B of Design Standard EN15714 - 3 provides information in this regard.

A3 Divergent use

In consultation with the manufacturer EBRO-Armaturen International, the actuator can also be operated with media other than compressed air.



A4 Identification of the actuator

Each actuator is identified by a typeplate:

The typeplate on the actuator housing must not be covered after mounting the actuator to the valve and after installation in the pipe section, so that the actuator remains identifiable.



 Danger	Exceeding the specified maximum pressure on the typeplate means danger for subsequent operation.
--	--

A5 Transport and (intermediate) storage

	<i>Actuators with additional electrical assemblies:</i> In order to prevent corrosion damage to electrical components during storage, such components must be stored at a constant room temperature.
	If an actuator is already <u>mounted to the valve</u> : The transport note and storage regulations in the valve instructions apply. In all cases, the unit must be stored in closed rooms at a constant temperature.

For correct transport of an individually supplied actuator, please note the following:

- When transporting the packages, observe the symbols on the packaging.
- Leave the actuator in the factory packaging until use (mounting to the valve).
- Always place the actuator on its flat side - any mounted accessories (e.g. solenoid valve/limit switch or manual override) must be positioned at the top or side.
- Protect the actuator from dirt and moisture.
- If necessary, use restraining straps (not chains) as a transport aid.

	When attaching a strap make sure that it is not fastened to additional assemblies. Protect the actuator from damage during transport
	Only for special actuators with mounted (manual) override: As the manual override is generally heavier than the actuator, the restraining straps can also be attached to the housing (but not to the handwheel!) of the override.



B) Mounting the actuator to the valve and connection of additional assemblies

	<p><i>This manual contains safety instructions for foreseeable risks when mounting the actuator to a valve.</i></p> <p>The user is responsible for supplementing these instructions for other risks, especially those typical of the valve. Fulfilment of all requirements for this system is assumed.</p>
---	--

The connection of any supplied electrical/electro-pneumatic additional assemblies is described in the supplied documentation.

These documents apply in addition to this manual.

B1 Safety instructions for mounting and connection

	<ul style="list-style-type: none">• Mounting and pneumatic/electrical connection of an actuator to operator system(s) may only be carried out by expert qualified personnel. For the purposes of this manual, experts are persons who, on the basis of their training, technical knowledge and professional experience, are familiar with pneumatic components and can correctly assess and execute the tasks assigned to them, and can identify and eliminate potential dangers. Knowledge of the typical properties of quarter turn valves (flap valves, ball valves) is also necessary for mounting; mounting and connection should also be carried out in consultation with expert colleagues if necessary.• Actuators are not "stepladders": external loads must be kept away from valve, actuator and feed lines.• Commissioning of an actuator, which is mounted to a valve, is only permitted if the valve is enclosed on both sides by a pipe or equipment section – any prior actuation entails a risk of crushing and is under the user's sole responsibility.
 Risk of crushing!	

B2 Interfaces

The purchaser must ensure the conformity of the following interfaces:

- a) Actuator/valve flange connection: with dimensions according to ISO 5211 (actuator and/or valve can have multiple bores!),
- b) Valve drive shaft/borehole, square socket/parallel key in actuator:
 - ▶ shape (=square or with parallel key) must match,
 - ▶ the valve manufacturer must have defined the appropriate dimensions and tolerances on the valve shaft.
- c) If accessories (e.g. solenoid valve/limit switch) have not been supplied by EBRO-Armaturen International, the purchaser must ensure the conformity of the functions / the interfaces between actuator and accessories; VDI/VDE 3845 is definitive in this respect.

B3 Individually supplied actuator Mounting on the valve

- Set actuator to <CLOSED> or <OPEN> position - depending on the valve position, using (temporary) compressed air supply, place actuator on valve and centre.
The actuator can be positioned as desired on the valve; the position can be defined in-situ.
- The screw connection must be tightened so that the drive torque is transferred by frictional contact – see table below. The flange size for the actuator is specified on the typeplate.
Tighten screws crosswise.

Flange size ISO	F04	F05	F07	F10	F12	F16
Tighten with [Nm]	5-6 Nm	8-10 Nm	20-23Nm	44-48 Nm	78-85 Nm	370-390 Nm

- The position indicator must be adjusted to match the position of the valve:
 - ▶ Indicator transverse to pipe axis: Valve is closed,
 - ▶ Indicator parallel to pipeline axis: Valve is open.

 Danger	An incorrect position indicator means danger for subsequent operation.
--	--

B4 All actuators: Connection to the compressed air supply

	At the start of the mounting process, you must ensure that the system data - control pressure, control voltage and frequency - of all subassemblies comply with the technical data marked on the typeplates of actuator and additional assembly (assemblies).
---	---

Non-binding recommendation for the feed line cross-section:

Size	EB4	EB5	EB6	EB8	EB10	EB12
Actuator volume / stroke [litres]	0.16	0.45	0.50	1.2	2.1	5.1
Recommended feed line Ø (up to 6m in length)	6 mm	6 mm	6 mm	6 mm	8 mm	8 mm
Shortest possible switching time (approx.) [s]	0.25		0.35	0.5	0.7	1.0

Note:

The shortest possible switching time according to this table is a guide value for standard **double-acting actuators without attached valve** and with optimal supply and disposal of the control medium. After mounting the actuator to the valve, this limit value is extended considerably.

The control diagrams for

- ▶ double-acting actuators EB SYD are shown in Figure 1
- ▶ single-acting actuators with spring reset EB SYS are shown in Figure 2.

Additional information can be found in the instructions for the solenoid valve.

The connection diagrams according to VDI/VDE 3845 (Namur) have a G ¼“ thread

**MOUNTING INSTRUCTION FOR PNEUMATIC QUARTER TURN ACTUATORS
EB4 – EB12 SYD AND EB5 – EB12 SYS**

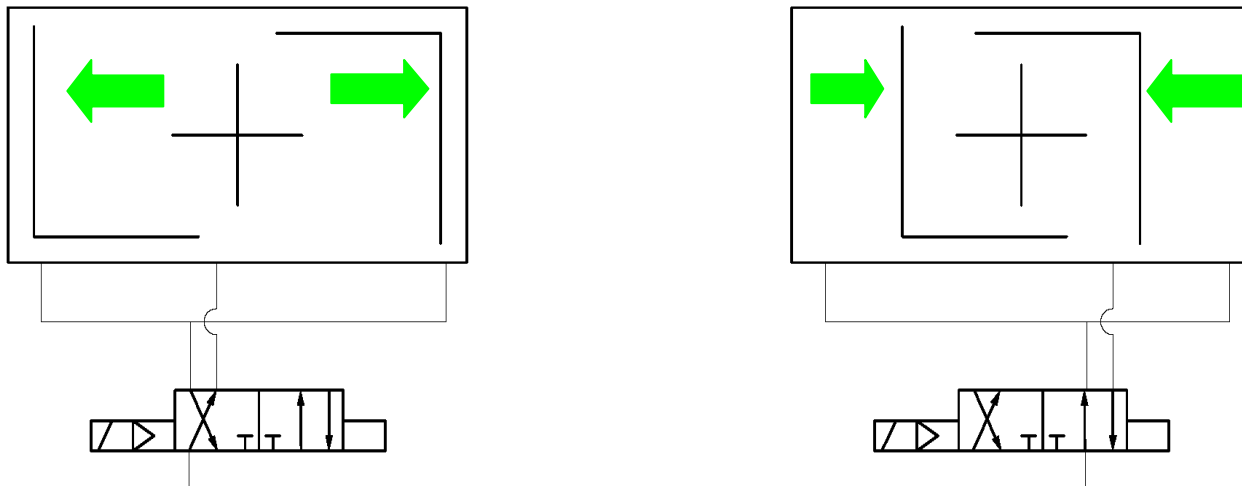

Figure 1: Schematic diagrams for double-acting actuators EB SYD

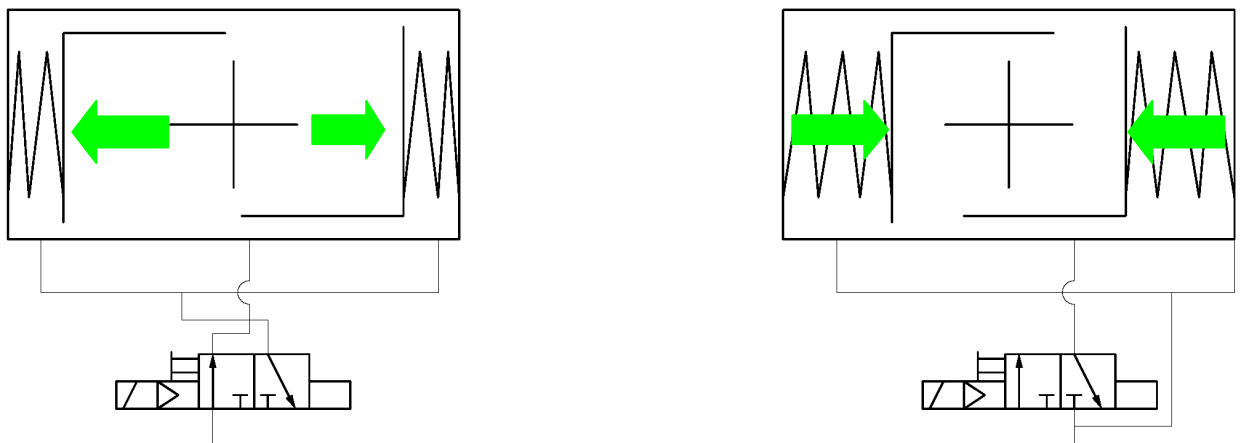

Figure 2 :Schematic diagrams for single-acting actuators EB SYS

	<p>In the standard design of the actuator, the supply of control air via the connection on the left must cause an anticlockwise actuation, and supply via the connection on the right must cause a clockwise actuation. Spring-resetting actuators must only be supplied via the connection on the left, see Figure 2</p>
--	--

B5 If required: Connection of additional electrical/pneumatic assemblies to the control

If such assemblies are connected, the instructions supplied by the component manufacturer must be complied with.

B6 All actuators: Adjustment of the normal <CLOSED> position

This section should only be applied if the valve manufacturer has not already precisely adjusted the <CLOSED> and <OPEN> positions.

The end stop in the actuator is adjusted for the <CLOSED> position ex-works: If required:
Adjust stop screw 27. (See figure on page13)

 Danger	The end positions may only be adjusted when the actuator is depressurized!
--	--

- Loosen both sealing nuts (28), unscrew end stop screws (27) a few turns.
- Change the piston position by turning the drive shaft (6), until the groove of the shaft square is parallel to the longitudinal axis of the cylinder.
- Screw in the end stop screws (27) on both sides until you can feel resistance, then tighten the sealing nuts (28).

B7 All actuators trial run: Test steps to conclude mounting and connection

To ensure perfect functioning of the actuator for automated operation, the following test steps must be performed **on every valve/actuator unit** after mounting:

- Do the position indicator on the actuator and the position of the valve match ?
If not, the position of the indicator must be readjusted.

 Danger	An incorrect position feedback (and incorrect optical display) mean danger for subsequent operation.
--	--

- Is the control pressure "in-situ" adequate?
The control pressure marked on the actuator typeplate must be present directly at the solenoid valve as a minimum, and "smooth" actuation of a valve under operating conditions ensured.
- Is the solenoid valve correctly connected?
When control pressure is present but the control signal fails (as test: e.g. remove connector) the valve must move into the position specified by the purchaser:

Actuator type	Type ID	the valve must
double-acting	EB□ SYD	<i>unless specified otherwise in the order:</i> move into the "CLOSED" position;
spring-closing	EB□ SYS	move into the "CLOSED" safety position;
spring-opening		move into the "OPEN" safety position.

If this is not the case, the control and/or the switching of the solenoid valve must be corrected accordingly. Remedy: see section C3: Troubleshooting.

- Actuator/valve connection correctly tightened?
During the functional check, no relative movements between valve, mounting bracket (if present) and pneumatic actuator must be detected. Retighten all screws of the flange connection if necessary, see table in section B3.
- Check actuating function and display:
When control pressure is present, the valve must **move into the corresponding positions** with the **"CLOSED"** and **"OPEN"** control commands. The visual display on the actuator (and on the valve, if applicable) must indicate this correctly.
If it is incorrect, the actuator control and/or the indicator position must be corrected accordingly.
- Check electrical position feedback (if component present):
The electrical signals for the **"OPEN"** and **"CLOSED"** display (in the system-side control centre) must be compared with the visual display on the valve. **Signal and display must match.** If they do not, the control and/or the adjustment of the position indicator must be checked. The component manufacturer's installation instructions must be complied with.

B8 Additional information: Demounting the actuator

The same safety regulations must be complied with as for the pipeline system, the compressed air supply and the (electrical / electro-pneumatic) control system.

Then follow the steps below:

- Mark assignment of actuator position / to valve position and record for remounting.
- Interrupt compressed air supply safely, depressurize valve if necessary.
- Disconnect compressed air supply and control connections.
- Loosen flange connection of valve/actuator and remove actuator from the valve.



C) Operating instructions

In accordance with MD 2006/42/EC, the manufacturer must compile a comprehensive risk analysis. EBRO-Armaturen provides the following documents for this purpose:

- These mounting and operating instructions,
- The declaration pertaining to EC directives provided at the outset.

	<p><i>This manual contains safety instructions for foreseeable risks when using the actuator for industrial applications.</i></p> <p>The user is responsible for supplementing these instructions for other risks, especially those typical of the valve.</p>
---	---

C1 *Safety instructions for operation*

	<ul style="list-style-type: none"> • The functioning of a pneumatic actuator mounted to a valve must comply with the <Intended use>, which is described in section A2. • The conditions of use must conform to the identification on the actuator typeplate A standard design of actuator must be operated exclusively within the permitted temperature limits of -20°C and +80°C (EBRO standard). • All work on the actuator may only be carried out by expert personnel. For the purposes of this manual, experts are persons who, on the basis of their training, technical knowledge and professional experience, can correctly assess and execute the tasks assigned to them, and can identify and eliminate potential dangers.
 Risk of crushing!	<p>The operation of an actuator which is mounted to a valve is only permitted if the valve is enclosed on both sides by a pipe or equipment section – any prior actuation entails a risk of crushing and is under the user's sole responsibility.</p>

C2 *Automatic operation / Manual operation*

If the actuator is correctly connected in accordance with section B, it will operate automatically and is designed for continuous operation in accordance with EN15714-3, Table 1.

	<ul style="list-style-type: none"> • For stable functioning, the actuator requires a permanent supply of compressed air for pneumatic operation. • <Fail-safe> actuators move the valve into the predefined CLOSED or OPEN position after interruption (or switch-off) of the compressed air supply.
---	--

C3 *Troubleshooting*

Before carrying out troubleshooting measures, the safety instructions for mounting and repair work must be complied with. Troubleshooting measures may only be carried out by trained personnel.

**MOUNTING INSTRUCTION FOR PNEUMATIC QUARTER TURN ACTUATORS
EB4 – EB12 SYD AND EB5 – EB12 SYS**

The tools used must comply with the relevant requirements; be in perfect condition.

Before the quarter turn actuator is demounted for troubleshooting, the responsible operating department must provide clearance (safety disconnection).

The following troubleshooting table describes a selection of error causes occurring in our experience and measures for their elimination:

Error	Error cause	Error elimination
Quarter turn actuator does not respond	Power supply for 5/2-way solenoid valve interrupted	Establish power supply; functional check
	Control medium supply interrupted	Restore control medium supply; functional check
	Control pressure before actuator too low	Check control medium supply (adjust if necessary), functional check
	Solenoid valve defective	Disconnect solenoid valve and replace or repair; functional check
	Valve defective (jams)	See "Troubleshooting" for valve
	Actuator defective (loss of control pressure)	Demount actuator and repair; mount actuator, functional check
Quarter turn actuator cannot be moved into end positions	Stop screws misaligned	Adjusted stop screws; functional check
	Valve defective (jams)	See "Troubleshooting" provided by valve manufacturer

D) Technical Appendix / Planning Documents

Note:

This Appendix is not part of the <Original Mounting Instructions>, but simply provides additional information.

The planner/purchaser must ensure that the actuator is suitable for

- ▶ the valve on which it is mounted
- ▶ the system-side compressed air supply and the control system.

Important technical information in this regard is provided below.

D1 Standard actuator design

D1-1 Adaptation to the valve

Pneumatic quarter turn actuators of type EB□ SYD (double-acting) and type EB□ SYS (with opening or return spring) can be mounted on all quarter turn valves (90°) with a mounting flange as per EN ISO 5211.

D1-2 Output torques of the actuators

The output torques for the quarter turn actuators specified in section D5 are nominal torques. They are achieved with a compressed air supply with a nominal pressure of 5.5 bar.



The output torque changes with the compressed air pressure currently operative on the actuator.

- ▶ Overpressures up to 8 bar are covered by the actuator design,
- ▶ Underpressures must be taken into account by the planner/purchaser when selecting the actuator size – also see D 1.4 below.

D1-3 Rotational direction of the actuator

Design standard EN 15714-3 specifies that the valve must close in a clockwise direction. This must be ensured in-situ through correct connection of the solenoid valve to the power supply and control – also see section B4 – the documentation of the solenoid valve must provide the necessary information.

D1-4 Valve assignment

The fundamental influencing factors for the required operating torque are determined by the valve (nominal width), the operating pressure and the medium. The necessary operating torque for the valve, which must be specified by the valve manufacturer, results from these parameters.

It is recommended that a safety reserve is added to this value for the design of the actuator.

D1-5 Self-locking when stationary

The driving torque as per the technical data in section D3 is achieved

- ▶ by all double-acting quarter turn actuators - only when control pressure is present,
- ▶ and by all <fail-safe> actuators with springs - in the end positions.

The hydraulic torque of the medium cannot generally influence the position of the shut-off device

D1-6 Service life

The design of the actuator as per EN 15714-3, Table 1 is the requirement for type testing of the actuator in endurance testing at 30% of the nominal capacity under laboratory conditions.

If and when maintenance of the actuator is required, depends on the operating conditions – particularly the pressure and cleanliness of the compressed air:



Generally the maintenance interval for an actuator is considerably longer than the maintenance intervals for the valve:

▶ When maintenance of the valve is carried out, perfect functioning of the actuator should at least be checked and ensured.

D1-7 Manual override

Manual override with an additional free-wheel gear is not standard on pneumatic actuators.

D1-8 Installation position

The valve/quarter turn actuator unit can be installed in any position.

- ▶ Arrangement above the valve is the normal position for an actuator,
- ▶ The design of the valve can restrict the possible installation positions,
- ▶ If the valve shaft is horizontally positioned and the actuator has an additional manual gear, the system planner or valve manufacturer must decide whether the actuator will exert an unacceptable torsional moment on the valve and/or the pipe, and must therefore be supported.

D1-9 Corrosion protection

This corresponds to Corrosion Category C4, according to standard EN 15714-3 for pneumatic actuators.

D2 Optional additional equipment

D2-1 Solenoid valve

At customer request, a solenoid valve can be supplied and directly mounted – its make, voltage and current type (DC or AC) must be specified.

D2-2 Limit switches (for position detection)

At customer request, 2 (or more) limit switches for "OPEN" and "CLOSED" feedback can be supplied and directly mounted – make, voltage and current type (DC or AC) must be specified for the magnet.

D2-3 Manual override (with additional gear)

At customer request, a wormgear with manually engaging clutch can be mounted to the quarter turn actuator.

**MOUNTING INSTRUCTION FOR PNEUMATIC QUARTER TURN ACTUATORS
EB4 – EB12 SYD AND EB5 – EB12 SYS**

Technical features of the actuator

Type EB□ SYD - double-acting and EB□ SYS – single-acting

Drive torque, double-acting, in Nm



Type	Control pressure										
	3 bar	3.5 bar	4 bar	4.5 bar	5 bar	5.5 bar	6 bar	6.5 bar	7 bar	7.5 bar	8 bar
EB 4	13.5	16	18	20	22,5	25	27	29	31,5	34	36
EB 5	38	44.5	51	57	63	70	76	82	89	95	101
EB 6	78	91	104	117	130	143	156	169	182	195	208
EB 8	125	146	166	187	208	229	250	271	292	312	333
EB 10	265	309	353	397	441	485	530	574	618	662	706
EB 12	435	507	580	652	725	797	870	942	1015	1087	1160

Drive torque, single-acting, in Nm

Actual air torque in Nm at control pressure															
Type	Variant	Springs n	Spring torque Md F in Nm		3 bar		4 bar		5 bar		6 bar		7 bar		kg
			0°	90°	0°	90°	0°	90°	0°	90°	0°	90°			
EB 5	VI	2	17	27	21	11	34	24	46	36	59	49	72	62	2,7
	V	2	22	35			29	16	41	28	54	41	67	54	2,8
	IV	2	27	44					36	19	49	32	62	45	2,8
	III	3	30	49					33	14	46	27	59	40	2,8
	II	3	35	58							41	18	54	31	2,9
	I	4	44	71									45	18	3,0
EB 6	VI	2	35	57	43	21	69	47	95	73	121	99	147	125	4,2
	V	2	45	74			59	30	85	56	111	82	137	108	4,5
	IV	2	55	90					75	40	101	66	127	92	4,6
	II	3	63	102					67	28	93	54	119	80	4,6
	II	3	73	119							83	37	109	63	4,8
	I	4	90	148									92	34	5,0
EB 8	VI	2	48	82	77	43	118	84	160	126	202	168	244	210	6,7
	V	2	65	111			101	55	143	97	185	139	227	181	6,9
	IV	2	82	140					126	68	168	110	210	152	7,1
	III	3	90	152					118	56	160	98	202	140	7,2
	II	3	107	181							143	69	185	111	7,4
	I	4	131	223									161	69	7,7
EB 10	VI	2	107	182	158	83	246	171	334	259	423	348	511	436	11,5
	V	2	145	231			208	122	296	210	385	299	473	387	12,0
	IV	2	182	279					259	162	348	251	436	339	13,0
	III	3	198	322					243	119	332	208	420	296	13,0
	II	3	236	370							294	160	382	248	14,0
	I	4	290	462									328	156	14,3
EB 12	VI	2	185	309	250	126	395	271	540	416	685	561	830	706	20,5
	V	2	241	392			339	188	484	333	629	478	774	623	21,0
	IV	2	296	475					429	250	574	395	719	540	23,0
	III	3	333	546					392	179	537	324	682	469	23,0
	II	3	389	630							481	240	626	385	24,0
	I	4	482	784									533	231	25,4

D4 Notes on risks arising from continuous operation

- The actuator is designed for continuous operation in accordance with EN15714-3, Table 1.
- **The actuator is screwed to the valve in the interface as per ISO5211. Section B2 contains the necessary tightening torques for the screw connection.**
Secure fitting of this screw connection must be monitored by means of visual inspection at appropriate intervals (during valve maintenance at the latest) on actuators with a high operating frequency, and the connection tightened if required.
- **The actuator is designed for operation with clean and dry compressed air in accordance with section 1 <Intended use>.**

	The material selection and manufacturing tolerances of the valve drive shaft interface must be adapted to the frequency of the switching operations <u>by the valve manufacturer</u> in accordance with the requirements of EN 5211:
	The <CLOSED> position of the valve is generally adjusted when mounting the actuator. As long as the valve is tight, this setting should not be changed. If readjustment is necessary, detailed information is provided in the EBRO Mounting Instructions MA4.0-MRL Section B6 and/or the relevant valve manual.

D5 Notes on other risks

- *Protection of pretensioned springs:*
The spring sets of type EB□ SYS are pretensioned and provided with appropriate protection. This protecting sleeve must not be changed by the user. Springs must not be exposed to any corrosive control medium.
- *Replacement of spring sets:*
Spring sets of type EB□ SYS can be replaced, if required by the torque requirement of the valve.
- *Mechanical loads:*
 - ▶ Actuators are not "stepladders": external loads must be kept away from valve, actuator and accessories.
 - ▶ The actuator is designed for a static load in the pipe system. Risks arising from loads caused by vibrations in the system are not covered. In such cases, the long-term protection of the screw connections on the actuator must at least be agreed with the manufacturer, EBRO-Armaturen.

Declaration in accordance with EC Directives

The manufacturer **EBRO Armaturen International Est. Co.KG**
Eschen, Zweigniederlassung Cham
Gewerbestrasse 5
CH-6330 Cham, Switzerland

declares that the pneumatic quarter turn actuators

Type EB4 - EB12 SYD double-acting
Type EB5 - EB12 SYS single-acting

are manufactured in accordance with the requirements of the following standards:

DIN EN ISO 5211	Connection of quarter turn actuators to valves
DIN EN 15081	Mounting sets for connection of quarter turn actuators to valves
VDI / VDE 3845	Actuator interfaces
EN 12100	Safety of machinery
ISO 8573-1 Cl. 3 and 5	Quality of compressed air

The following product documents are available:

Technical data sheets, 04-01-EB-DW, 04-02-EB-EW

These products comply with the following specified directives:

Machinery Directive 2006/42 EC (MD) [only applies in conjunction with a valve.]

1. The products are an "incomplete machine" for the purpose of Art 2 g) of this directive
2. The table overleaf lists whether and how requirements of this directive are fulfilled
3. This declaration is the mounting declaration for the purpose of this directive

For compliance with the above-specified directives, the following applies:

1. The user must observe the <intended use>, which is defined in the "Original Mounting and Operating Instructions" (BA 4.0-MRL Rev. 0/2009) provided with the delivery, as well as the information in this manual. Disregard of these instructions can – in important cases – release the manufacturer from its product liability.
2. Commissioning of the valve (and of the mounted actuator, if applicable) is forbidden, until the conformity of the system, in which the valve is installed, with all applicable abovementioned EC directives is declared by the party responsible. A separate declaration is provided for the abovementioned actuator.
3. The manufacturer EBRO-Armaturen has performed and documented the required risk analyses; the member of staff responsible for this documentation is Ms./Mr. Kliemisch at EBRO-Armaturen.

Hagen, 21.12.2009



Olaf Kliemisch, Product Manager Actuator Technology

**MOUNTING INSTRUCTION FOR PNEUMATIC QUARTER TURN ACTUATORS
EB4 – EB12 SYD AND EB5 – EB12 SYS**

The Manufacturer	EBRO ARMATUREN Gebr. Bröer GmbH, D58135 Hagen
declares, that the EBRO pneumatic actuators EB SYD/SYS comply with the:	
requirements according to Appendix I MD 2006/42/EC	
1.1.1, g) Intended use	See Operating Manual
1.1.2.,c) Warnings against misuse	See Operating Manual
1.1.2.,c) Protective equipment required	Exactly as for pipe section in which the valve is installed
1.1.2.,e) Accessories	No special tool required for replacing wearing parts
1.1.3 Components in contact with media	The materials of components in contact with media are agreed prior to delivery and are specified in both the type data sheet and in the EBRO order confirmation. It is assumed that the user will carry out a corresponding risk analysis for resistance to the operating medium.
1.1.5 Handling	Fulfilled by the notes in the Installation Instructions
1.2 and 6.2.11 Control	Under the user's responsibility, in coordination with the installation instructions for the actuator
1.3.2 Prevention of risk of breakage	For functional parts: ensured by "Intended use" of the actuator
1.3.4 Sharp corners and edges	Requirement fulfilled
1.3.7/8 Injury from moving parts	Requirement fulfilled with "Intended use". Maintenance and repair of the actuator are only permitted when the actuator is stationary and the energy supply switched off
1.5.1 - 1.5.3 Energy supply	Under the user's responsibility. Also see Installation Instructions for the actuator
1.5.5. Operating temperature	Warning against unacceptable exceeding: see Operating Manual, section <Intended use>
1.5.7 Explosion	⊕ protection necessary. Must be expressly agreed in the purchase contract. In this case: Use only as marked on the actuator.
1.5.13 Emission of hazardous substances	Not applicable
1.6.1 Maintenance	See Operating Manual. Agree stocking of wearing parts with EBRO Armaturen International Est. + Co.KG.
1.7.3 Identification	Valve: According to Mounting Instructions. Actuator: See actuator manufacturer's documentation.
1.7.4 Operating instructions	These Installation Instructions also contain information on operating the actuator. Necessary additions for the operating instructions for the <complete machine> are the responsibility of the planner / user.
Appendix III	The actuator is not a <complete machine>: therefore no EC marking for conformity as per Machinery Directive
Appendices IV, VIII-XI	Not applicable
in accordance with EN 12100	
1. Field of application	The basis is the decades of experience in the use of the actuator types specified on page 1. <i>Note: It must be assumed that the user will perform a risk analysis for the pipe section including the valves used in it, specifically tailored to the operating case, in accordance with sections 4 to 6 of EN 12100 – such an analysis is not possible for the manufacturer, EBRO Armaturen International Est. + Co.KG., in the case of standard valves.</i>
3.20, 6.1 Inherently safe design	The actuators are manufactured in accordance with the principle of <inherently safe design>
Analysis in accordance with sections 4, 5 and 6	Experiences of malfunctions and misuse documented by the manufacturer within the scope of cases of damage (documentation according to ISO9001) have been used as the basis.
5.3 Limits of the machine	The demarcation of the <incomplete machine> has been made on the basis of the <intended use> of the actuator.
5.4 Decommissioning, disposal	Not in the area of responsibility of the manufacturer EBRO Armaturen International Est. + Co.KG.
6.2.2 Geometrical factors	As valve and actuator enclose the functional parts during intended use, this section is not applicable.
6.3 Technical protective devices	If applicable, only necessary for accessories – see order confirmation.
6.4.5 Operating instructions	As valves with actuators operate "automatically" according to the commands of the control, the operating instructions describe those aspects that are <actuator-typical> and must be made available to the manufacturer of the (pipe) system
Risk analysis	The risk analysis performed has been carried out in accordance with MD Appendix VII, B) by the manufacturer EBRO Armaturen International Est. + Co.KG and is documented in accordance with MD Appendix VII B).