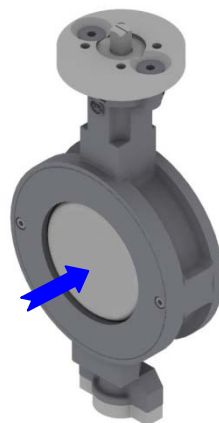

## High-Performance Butterfly Valves HP Series

**HP111****HP112****HP112-S****HP114****HP120****HP111-E****-L****-KOB**

Example representations, not all possible type variants are shown!

## Mounting Instructions with Operating Instructions and Technical Appendix

in accordance with EC Machinery Directive 2006/42/EC  
in accordance with EC Pressure Equipment Directive  
97/23/EC

*English Version*

# Contents

	Page
<b>A) GENERAL</b>	<b>3</b>
A1 EXPLANATION OF SYMBOLS	3
A2 INTENDED USE	3
A3 IDENTIFICATION OF THE BUTTERFLY VALVE	4
A4 TRANSPORT AND STORAGE	4
<b>B) INSTALLATION OF THE VALVE IN THE PIPELINE / PRESSURE TEST</b>	<b>5</b>
B1 SAFETY INSTRUCTIONS FOR INSTALLATION	5
B2 PREREQUISITES FOR INSTALLATION IN THE PIPELINE	5
B3 INSTALLATION PROCEDURE	6
B4 PRESSURE TEST BEFORE/DURING COMMISSIONING	8
B5 ADDITIONAL INFORMATION: DISASSEMBLY OF THE VALVE	8
<b>C) OPERATING INSTRUCTIONS</b>	<b>9</b>
C1 SAFETY INSTRUCTIONS FOR OPERATION AND MAINTENANCE	9
C2 MANUAL OPERATION / AUTOMATIC OPERATION	9
C3 TROUBLESHOOTING	10
<b>D) TECHNICAL APPENDIX / PLANNING DOCUMENTS</b>	<b>11</b>
D1 TECHNICAL SPECIFICATION OF THE VALVE	11
D2 P/T RATINGS	11
D3 DRAWING / PARTS LIST	11
D4 SPARE PARTS	11
D5 FLANGE SCREWS FOR TYPES HP, HP-E AND VARIANTS	12
<b>DECLARATION IN ACCORDANCE WITH EC DIRECTIVES</b>	<b>13</b>

You can find additional information and current addresses for our branches and trade partners at:





[www.ebro-armaturen.com](http://www.ebro-armaturen.com)

EBRO ARMATUREN GmbH  
 Karlstraße 8  
 D-58135 Hagen  
 ☎ (02331) 904-0  
 Fax (02331) 904-111

## A) General

### A1 *Explanation of symbols*

Notes are indicated by the following symbols in these Instructions:

	<p><b>Absolute prohibition</b> .....must be complied with</p>
 XXXXXX	<p><b>Danger / Caution / Warning</b> ... indicates a hazardous situation, which can result in death or severe injuries for people and/or damages in the pipe system.</p>
	<p><b>Note</b> ... indicates an instruction that must be complied with.</p>
	<p><b>Information</b> ... provides useful tips and recommendations</p>

Failure to observe these notes, cautions and warnings could give rise to dangers and invalidate the manufacturer's warranty.

### A2 *Intended use*

The **HP series** of butterfly valves are intended for installation between flanges in a pipe system or with a welded joint on both sides, for the purpose of shutting off or conducting media within the permissible upper pressure and temperature limits, or regulating their flow.

The permissible upper pressure and temperature limits (depending on the housing material and the seat material) are identified with **TS** and **PS** on the valve typeplate (see section A3). Below these limits, the permissible <p/t rating> is described, depending on the housing material, in the planning documents in section D2I.

The valve may only be commissioned after noting the following documents:

- <Explanations in relation to EC directives> – see above
- These Mounting / Operating Instructions, which are enclosed with the delivery.

Use of the valve in a potentially  atmosphere is only permitted, if

► expressly indicated by the customer.

Failure to observe this <Intended use> constitutes gross negligence and releases the manufacturer, EBRO-Armaturen, from its product liability.

### A3 Identification of the butterfly valve

Every butterfly valve bears an identification with the following data on the housing or typeplate:

for	Identification	Comment
Manufacturer	<b>EBRO-ARMATUREN</b>	Address, see page 2 <Contents>
Valve type	e.g.: <b>HP111</b>	(Housing identification) See overview on page 1
Conformity	<b>EC</b>	Conformity with Pressure Equipment Directive 97/23EC
Identification no.	<b>0036</b>	Appointed body as per EU Directive = TÜV South Germany
SN (serial no.)	e.g. <b>123456/012/001 *</b>	Numbers 1-6: EBRO order no., numbers 7-9: order item, numbers 10-12: consecutive no. for an order item
DN	<b>DN (and numerical value)</b>	(Housing identification) e.g. DN80
PN	e.g. <b>PN 40</b>	is the required PN level of the mating flange
Max. permissible temp.	<b>TS (and numerical value)</b>	Numerical values for upper and lower operation limits
Max. permissible pressure	<b>PS (and numerical value)</b>	Numerical value in bars (at room temperature)
Material	e.g.: <b>1.0619</b>	(Housing identification) Housing material
	e.g.: <b>1.4408</b>	(On typeplate) Material of valve disc
	e.g.: <b>1.4418</b>	(On typeplate) Material of stem
	e.g.: <b>Inconel 625</b>	(On typeplate) Material of replaceable seat ring

\*) **Note:** The year of manufacture is encoded in the serial no.

The typeplate must not be covered, so that the installed valve remains identifiable.

### A4 Transport and storage

The following points must be noted for correct transport:

- Leave the valve in the factory packaging until use (mounting).
- Store the valve in closed rooms and protect from dirt and moisture.
- Stop of retention straps as per Figures 1 to 3,

- **Only type KOB (valve with loose seat ring):**  
Transport is not permitted with the valve disc on the bottom, as shown in Figure 4



Do not suspend large valves from the gear or actuator!  
Protect valve disc and flange sealing surfaces from damage

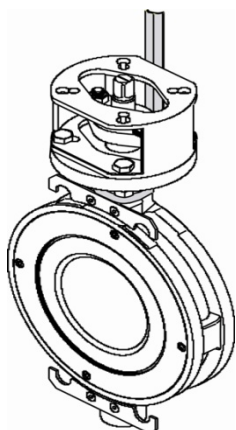

Figure 1

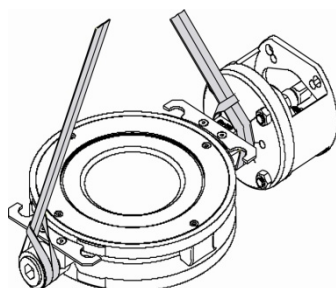

Figure 2

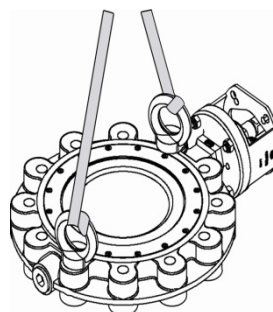

Figure 3

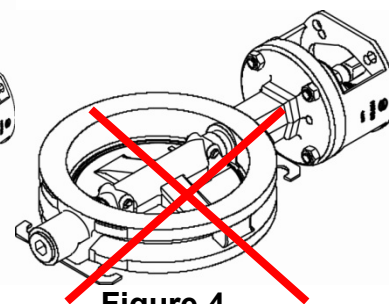

Figure 4



**Valves supplied without actuator:**

The valve disc is not protected against displacement. It must be transported in such a way that it cannot open from the closed position as a result of external influences (e.g. vibration).

## B) Installation of the valve in the pipeline / pressure test



*These Instructions contain safety information pertaining to foreseeable risks when installing the valve in a (pipe) system.*

The user is responsible for supplementing the following information for other risks specifically related to the location. Fulfilment of all requirements for this system is assumed.

### B1 Safety instructions for installation



- The installation of valves in the system may only be carried out by expert personnel. For the purposes of these Instructions, experts are persons who, on the basis of their training, technical knowledge and professional experience, can correctly assess and execute the tasks assigned to them, and can identify and eliminate potential dangers.
- The intended function of a valve after installation must comply with the <Intended use>, which is described in section A2.
- A valve which is not locked in (any) position with an actuator must not have pressure applied to it.
- The operation of an actuator which is mounted to a valve, is only permitted if the valve is enclosed on both sides by a pipe or equipment section – any prior operation entails a risk of crushing and is under the user's sole responsibility.
- A valve which externally terminates a pipe section under pressure as an <end fitting> must be protected by a blind cover, so that no external leaks can occur.

### B2 Prerequisites for installation in the pipeline

- Only install butterfly valves whose pressure class and materials comply with the intended operating conditions. See relevant identification on typeplate (*section A3*)
- Generally the butterfly valve must either be equipped with a hand lever/gear handwheel or with an actuator and adjusted ready for operation.  
A valve is only supplied without an actuator for subsequent retrofitting in special cases.
- A butterfly valve without visible transport damages should be left in the factory packaging during storage and transport, and only unpacked immediately before installation in the pipe section.



**Caution**

***The inside of the housing is very finely machined, in order to ensure the tightness of the (closed) butterfly valve. It must be ensured that this surface is not damaged when handling during installation.***

- Flanged valves must be installed on or between flanges as per EN 1092-1 or EN 1759-1, with sealing strips as per Form A or B1, which must be plane-parallel and aligned. The use of other flanges and/or other forms of sealing strip must have been confirmed in the order confirmation by the manufacturer, EBRO Armaturen.

- The inner width of the mating flange must leave sufficient space for the opened valve disc, so that the disc is not damaged when swiveling out, thus becoming unusable.  
See table. *The dimensions can differ depending on type*

	<i>Minimum required internal diameter <math>D_i</math> of the mating flange</i>														
	<b>DN</b>	50	65	80	100	125	150	200	250	300	350	400	450	500	600
<b>Ø <math>D_i</math></b>	51	51	80	103	124	151	196	245	296	334	385	438	484	560	

- All internal surfaces of the valve must be free from impurities – particularly hard/sharp particles. The pipe sections on both sides must also be clean: to flush a line with an installed valve, please observe note in section B3.

 If impurities (welding beads, rust particles etc.) are not removed, the sealing surface in the housing could be damaged: the valve will become leaky and, at the worst, unusable.

- The butterfly valve is in (almost) closed position when delivered, and must also be installed like this, in order to protect the finely polished seat surface on the disc from damage.
- The ends of the pipeline must be aligned and have plane-parallel connection faces.



 *Flange seals are generally not included in the scope of supply of EBRO-Armaturen:*  
Use flange seals as per EN1514-1, i.e. flat seal with form IBC or form FF with a thickness of approx. 1.5 - 2.0mm.  
The tightening torques of the flange screws depend on the type and material of the flange seals. See *EBRO Factory Standard EW 1810*.

**B3 Installation procedure**

- Check valve and actuator for transport damages. Damaged butterfly valves or actuators must not be installed.
- The preferred installation position for the valve is with the butterfly valve stem horizontal. The gear should - if possible - not be positioned directly beneath the valve: leaks from the stuffing box could damage gear or actuator.
- Butterfly valves for installation between flanges must be carefully centered with the flange screws during installation. For flange screws, also see section D5.
- In the case of butterfly valves for welding in, it must be ensured that minimal heat is introduced into the housing, in order to protect it from deformation.  
If necessary, welding should be carried out in sections with intermittent pauses.
- If in exceptional cases a valve is delivered without an actuator device, it must be installed in closed position and left like this until the actuator is retrofitted. The relevant installation instructions must be provided by the actuator manufacturer. The nominal torque must be adapted to the valve, and the setting of the "OPEN" and "CLOSED" end stops correctly adjusted.

 **Warning** It must be ensured that such a butterfly valve is not subjected to pressure before the actuator is mounted.

- Butterfly valves can be installed independently of the flow direction of the medium. But the direction of pressure in relation to the closed valve disc must be noted:

	In order to optimally utilise the function of the butterfly valve, the valve must be installed so that the pressure direction (direction exerted by the pressure in relation to a closed disc) matches the (blue) arrow direction in the photo on the title page. This direction can be opposed to the direction of flow when the butterfly valve is open. <i>In the case of valves with arrow direction marked on the housing, this direction corresponds to the pressure direction!</i>
	<i>Valve with pneumatic &lt;fail safe&gt; actuator (with opening spring):</i> A <fail safe> actuator with opening spring must be set to the closed position by means of an (alternative) compressed air connection for insertion between the mating flange. The installation instructions for the actuator must be observed and it must be ensured that the valve disc does not suddenly open unintentionally (risk of injury!).



- After installation, the valve disc must be opened for flushing the line, so that the pipe section can be flushed clean before the valve is closed for the first time.

	Before first closing, hard/abrasive impurities (welding beads, rust particles etc.) must be removed from the pipe section.
---	--

- *For installation at the end of a pipe section:*

 <b>Danger!</b>	If a butterfly valve is mounted as an end valve and subjected to pressure, it must be sealed with a blind flange in order to prevent physical injuries or damage to property in the event of leaks and/or unauthorised opening.
---	---

- For connection of an actuator to the system-side control, the relevant manufacturer's instructions apply.

	A gear or actuator is adjusted for the operating data specified in the order: The setting of the "CLOSED" end stop of a brand-new valve must not be changed unless the valve termination is leaky.
 <b>Note</b>	Only for butterfly valves with electric actuator It must be ensured that the actuator is switched off in the end positions by the position switch signal. A torque switch signal must be used for an error message. The fault must be eliminated as quickly as possible, see section C3 <Troubleshooting>. For further information, see Electric Actuator Instructions.

- To conclude installation, a functional check must be carried out: a butterfly valve with lever or handwheel must permit easy operation for the full swivel angle with the application of normal manual force.  
An actuator mounted to the butterfly valve must move smoothly into the <OPEN> and <CLOSED> positions in accordance with the marked control data and control commands.
- Incorrectly executed control commands can mean danger and cause damage in the pipe system. Visible functional faults must be eliminated before commissioning. Also see section C3 <Troubleshooting>

## **B4 Pressure test before/during commissioning**

All butterfly valves are subjected to a final inspection ex-works by the manufacturer in accordance with EN12266-1.

The test conditions for the pipe section apply for performing a pressure test on a valve in the system – but with the following limitations:

- The test pressure of a valve must not exceed **the value 1.5x PS** (according to the valve typeplate). **The valve disc must be in the open position.**
- If a **closed butterfly valve is subjected to more than 1.1x PS**, there is a risk that internal parts of the valve will be overloaded. This must be avoided in all events.



*As soon as the line is under pressure, the tightness of the stuffing box must be checked:*

In the event of leaks:

Immediately tighten nuts on stuffing box alternately in small steps, until the leak stops – do not tighten nuts more than necessary!

## **B5 Additional information: Disassembly of the valve**

The same safety regulations must be observed as for the (pipe) system and installation (see section B1).

- Check that the line is released, depressurised and drained.
- Close valve completely, remove flange screws. Spread flange with a tool.
- Remove the valve (do not damage the flange sealing surfaces when removing the valve) and store, ensuring that it is well protected. Protect the sealing surfaces.
- For attaching retention straps, note section A4.
- Type HP120 for welding in: the weld seam should be broken with minimal heat input. Actuator and mounting parts must be protected against damage from flying sparks (use covers!).

## C) Operating instructions

According to MD 2006/42/EC, the system planner must compile a comprehensive risk analysis. The manufacturer, EBRO-Armaturen, provides the following documents for this purpose:

- These mounting and operating instructions,
- The declaration pertaining to EC directives provided at the end.



*This manual contains safety instructions for foreseeable risks when using the valve for industrial applications.*  
The planner/operator is responsible for supplementing the following instructions for other risks, especially system-related risks.

### C1 Safety instructions for operation and maintenance



**Danger**

- The functioning of a valve must comply with the <Intended use>, which is described in section A2.
- The operational conditions must conform to the identification on the typeplate of the butterfly valve.
- Essential work on the valve may only be carried out by expert personnel. For the purposes of this manual, experts are persons who, on the basis of their training, technical expertise and professional experience, can correctly assess and execute the tasks assigned to them, and can identify and eliminate potential dangers.
- The butterfly valve stem is sealed by a stuffing box. Before the nuts on the stuffing box gland are loosened or unfastened, the pressure **on both sides** of the valve must be completely relieved, so that no medium escapes from the stuffing box.
- When the pipe section is pressurised for the first time, the tightness of the stuffing box must be checked:  
*In the event of leaks:*  
Immediately tighten nuts on the stuffing box alternately in small steps until the leak stops - do not tighten nuts more than necessary!
- Before loosening a lock screw or a screw on the housing cover, or before removing the complete valve from the pipe, the **pressure in the system or pipe section on both sides of the valve** must be completely relieved, to prevent uncontrolled escape of the medium from the pipe.



**Risk of crushing**

- The operation of an actuator which is mounted to a valve is only permitted if the valve is enclosed on both sides by a pipe or equipment section – any prior actuation entails a risk of crushing and is under the user's sole responsibility.

### C2 Manual operation / Automatic operation

A butterfly valve with manual operation closes by turning the lever or handwheel clockwise and opens in the opposite direction.

A butterfly valve with an actuator must be operated with the control signals. Butterfly valves which have been supplied with an actuator ex works are precisely adjusted ex works - this adjustment in the gear/actuator should not be adjusted as long as the valve is functioning perfectly.

The only maintenance required is visual inspection of the tightness of the stuffing box at appropriate time intervals – in the event of leaks, see section C3 <Troubleshooting>.

Butterfly valves that remain permanently in one position should be operated at regular intervals, in order to ensure freedom of motion.

**C3 Troubleshooting**

Type of fault	Measure
Leak at flange connection to pipe	Seal flange connection between housing and pipe: Follow instructions in Pipe Operating Manual.
Leak at stuffing box	<p>Tighten both nuts on the stuffing box gland alternately and in small steps of ¼ revolution each <u>clockwise</u>.</p> <p><i>If the leak cannot be eliminated by these means:</i> Repair necessary: Request spare parts and necessary instructions from EBRO-ARMATUREN.</p> <p><i>If nuts on stuffing box gland must be loosened or unscrewed (counterclockwise!)</i></p> <div style="text-align: center;">  <p><b>Mortal danger</b></p> </div> <p>To protect the operating personnel from danger, make sure that the line is depressurised on both sides of the valve beforehand. Note section C1 &lt;Safety instructions&gt;.</p>
Leak in seat seal	<p>Check that the valve is 100% closed with full operating torque.</p> <p><i>If the valve still leaks in closed position:</i> Open/close valve under pressure several times.</p> <p><i>If valve still leaks:</i> Repair necessary: replace seat seal. Note information in section C1 &lt;Safety instructions&gt; and request spare parts and necessary instructions from EBRO-ARMATUREN.</p>
Malfunction	<p>Remove valve (follow instructions in section B5 and C1 &lt;Safety instructions&gt;) and inspect.</p> <p><i>If the valve is damaged:</i> Repair necessary: Request spare parts and necessary instructions from EBRO-Armaturen.</p>

## D) Technical Appendix / Planning Documents

Note:

This Appendix is not an integral part of the Mounting and Operating Instructions and is only an excerpt from the catalogue documents of EBRO-Armaturen for this valve type – if you require the complete catalogue, please see addresses in the Table of Contents.

### D1 Technical specification of the valve

Butterfly valves of type <HP> conform to the following design standards:

- ▶ **EN 593: Butterfly valves with housing made from metallic materials**

### D2 p/t ratings

**Note:** The following data for the permissible operating pressure depending on the operating temperature (excerpt from EN12516-1:2005 – standard assignment) apply for the permissible limit of the pressure/temperature assignment p/t of the complete valve (as part of the pipe).

1.0619 = Group 3E0						1.4408 = Group 14E0					
Type HP DN50-150		Type HP DN200-600		Type HP-E		Type HP DN50-150		Type HP DN200-600		Type HP-E	
Temperature [°C]	B 40 [bar]	Temperature [°C]	B 25 [bar]	Temperature [°C]	B20 [bar]	Temperature [°C]	B 40 [bar]	Temperature [°C]	B 25 [bar]	Temperature [°C]	B20 [bar]
RT	39.0	RT	24.4	RT	19.5	RT	38.8	RT	24.3	RT	19.4
50	37.2	50	23.2	50	18.6	50	36.9	50	23.1	50	18.5
100	34.1	100	21.3	100	17.1	100	33.2	100	20.7	100	16.6
150	31.7	150	19.8	150	15.8	150	29.9	150	18.7	150	15.0
200	28.4	200	17.8	200	14.2	200	27.5	200	17.2	200	13.7
250	26.0	250	16.2	250	13.0	250	25.6	250	16.0	250	12.8
300	23.5	300	14.7	300	11.8	300	24.1	300	15.0	300	12.0
350	21.9	350	13.7	350	11.0	350	22.7	350	14.2	350	11.4
375	21.6	375	13.5	375	10.8	375	22.4	375	14.0	375	11.2
400	21.1	400	13.2	400	10.6	400	21.8	400	13.6	400	10.9

For the <Tight closing (in the seat)> function, the max. permissible operating temperature is generally "capped" by the choice of a seat seal – this upper limit is marked on the typeplate and can be found in the EBRO Armaturen catalogue documents (as p/t rating chart). It is an empirical value, which takes account of lifetime, wear, degree of tightness etc.

### D3 Drawing / Parts list

The drawings and typical parts lists assigned to the valves can be downloaded from the EBRO - "Download menu" (for address, see page 4 or link).

<http://www.ebro-armaturen.com>

### D4 Spare parts

In the parts lists described under section **D3**, the spare parts are identified with the note "**(empfohlenes Ersatzteil / recommended spare part)**". Only genuine EBRO parts may be fitted. Spare parts and necessary instructions can be requested from EBRO ARMATUREN.

**D5 Flange screws for types HP, HP-E and variants**

The flange screws assigned to the valves can be found in the EBRO ARMATUREN factory standard sheets EW 1810 and EW 1820 ff. These can be downloaded in the "Download area" (for address see page 4 or link provided below).

<http://www.ebro-armaturen.com/doku>

## Declaration in accordance with EC Directives

The manufacturer

**EBRO Armaturen**  
**Gebr. Bröer GmbH**  
**Karlstrasse 8**  
**58135 Hagen**  
**Germany**

declares that the valves

**EBRO butterfly valves with centric and eccentric design**  
**Series Z, F, M, T, TW, BE and Series HP**

are manufactured in accordance with the requirements of the following standards:

**EN 593**                      **Product standard for butterfly valves with metallic housing**  
**prEN 12100:2009**        **Safety of machinery - basic concepts, general design principles**

The following product documents are available:

**Planning documents, Technical data sheets, catalogue sheets**

These products comply with the directives specified below:

**Pressure Equipment Directive 97/23 EC (DGRL)** [applicable if Art 3 para. 1.3 or Art. 3 para. 3 applies]

The valves conform to this directive. The conformity assessment procedure used in accordance with Appendix III of the Pressure Equipment Directive 97/23 EC is

-	For Category I	Module A
-	For Category II and III	Module H
-	For Category IV	Module B + D

Name of appointed body: TÜV Süd

ID no. 0036

**Machinery Directive 2006/42 EC (MD)** [applicable if the valve is not manually operated.]

1. The products are an "incomplete machine" for the purpose of Art 2 g) of this directive
2. The table overleaf lists whether and how requirements of this directive are fulfilled
3. This declaration is the declaration of incorporation for the purpose of this directive

For compliance with the above-specified directives, the following applies:

1. The user must observe the <intended use> as defined in the "Original Mounting and Operating Instructions" (BA 1.0-DGRL/MRL and BA 3.0-DGRL/MRL ) provided with the delivery, as well as all information in this manual. Disregard of these instructions can release the manufacturer from its product liability in important cases.
2. Commissioning of the valve (and of the mounted actuator if applicable) is forbidden until the conformity of the system, in which the valve is installed, with all applicable EC directives specified above is declared by the party responsible. A separate declaration is provided for the above mentioned actuator.
3. The manufacturer EBRO-Armaturen has performed and documented the required risk analyses; the member of staff responsible for this documentation is Mr. Bernhard Mitschke at EBRO-Armaturen.

Hagen, 4.12.2009

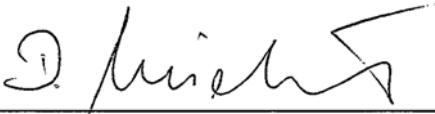
  
Dirk Mitschke, Managing Director

# MOUNTING INSTRUCTIONS FOR ECCENTRIC BUTTERFLY VALVES HP SERIES

<b>The manufacturer</b>	<b>EBRO ARMATUREN Gebr. Bröer GmbH, D58135 Hagen</b>
declares that the valve <b>"EBRO butterfly valves in centric and eccentric design"</b> conform to the following requirements:	
<b>Requirement according to Appendix I of the Machinery Directive 2006/42/EC</b>	
1.1.1. g) Intended use	See Mounting and Operating Instructions
1.1.2..c) Warnings against misuse	See Mounting and Operating Instructions
1.1.2..c) Protective equipment required	Exactly as for pipe section in which the valve is installed
1.1.2..e) Accessories	No special tool required for replacing wearing parts
1.1.3 Components in contact with media	All materials in contact with media are specified in the type data sheet and in the order confirmation. The performance fo a corresponding risk analysis by the user is required.
1.1.5 Handling	Fulfilled by the notes in the Mounting and Operating Instructions
1.2 and 6.2.11 Control	Under the user's responsibility, in coordination with the actuator instructions
1.3.2 Prevention of risk of breakage	For pressurised parts of the valve: certified by certificate of conformity with DGRL 97/23 EC For functional parts: ensured by intended use of the actuator
1.3.4 Sharp corners and edges	Requirement fulfilled
1.3.7/8 Risk of injury from moving parts	Requirement fulfilled with intended use Maintenance and repair only permitted when the valve/actuator is stationary
1.5.1 – 1.5.3 Energy supply	Under the user's responsibility, also see actuator instructions
1.5.5 Exceeding of permissible temperature	See warning in Mounting and Operating Instructions, section <Intended use>
1.5.7 -Explosion	⊕ protection necessary. Must be expressly agreed in the purchase contract. In this case: Use only as marked on the valve
1.5.13 Emission of hazardous substances	Not applicable
1.6.1 Maintenance	See Operating Instructions. Clarify stocking of wearing parts with EBRO-Armaturen.
1.7.3 Identification	Valve: According to Mounting Instructions. Actuator: According to Mounting Instructions.
1.7.4 Operating instructions	Necessary additions for the complete instructions for the <complete machine> are outlined in the Operating Instructions document, see section C of the Mounting and Operating Instructions
<b>Requirement according to Appendix III</b>	The valve is not a <complete machine>: no EC marking for conformity with MD
<b>Requirements according to Appendix IV and Appendix VIII-XI</b>	Not applicable
<b>Requirement according to prEN 12100:2009</b>	
1. Field of application	The risk analysis for valve/actuator is prepared from the viewpoint of the <incomplete machine>. Product standard EN593:<Butterfly valves with metallic housing> with an actuator as per EN15714-2 or EN15714-3 , Class A was used as basis for the analysis. The basis is, furthermore, industrial application and on average >20 years of experience in the use of the above-specified valve types, resulting in the notes and warnings in the above mentioned Mounting and Operating Instructions. <i>Note:</i> <i>It must be assumed that the user will perform a risk analysis for the pipe section including the valves used in it, specifically tailored to the operating case, in accordance with sections 4 to 6 of EN 12100 – such an analysis is not possible for the manufacturer EBRO-Armaturen for standard valves.</i>
3.20, 6.1 Inherently safe design	The butterfly valves are manufactured in accordance with the principle of <inherently safe design>. <Intended use> is assumed.
Analysis in accordance with sections 4, 5 and 6	Experiences of malfunctions and misuse documented by the manufacturer within the scope of cases of damage (documentation according to ISO9001) have been used as the basis.
5.3 Limits of the machine	The demarcation of the incomplete machine has been made on the basis of the <intended use> of both the valve and the actuator
5.4 Decommissioning, disposal	Not in the manufacturer's area of responsibility
6.2.2 Geometrical factors	As valve and actuator enclose the functional parts during intended use, this section is not applicable.
6.3 Technical protective equipment	Only necessary for special actuators - see order confirmation
6.4.5 Operating instructions	As valves with actuators operate "automatically" according to the commands of the control, the operating instructions describe those aspects that are <valve-typical> and must be made available to the manufacturer of the (pipe) system
7 Risk analysis	The risk analysis performed has been carried out in accordance with Appendix VII, B) by the manufacturer EBRO-Armaturen and is documented in accordance with MD Appendix VII B).