

**DOCUMENTATION FOR
EBRO AT AS-INTERFACE
FOR LINEAR ACTUATORS**

VERSION 2.1

WITH EXPANDED ADDRESS MODE

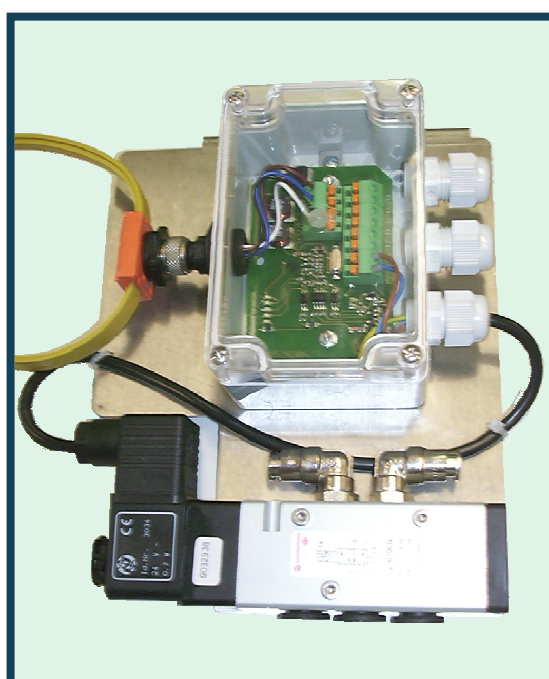

Example representations, not all possible type variants are shown!

**Mounting Instructions
with Operating Instructions and Technical Appendix**

**in accordance with EC 73/23/EC
in accordance with EC 89/336/EC**

English Version

Contents

	Page
<u>A) GENERAL</u>	3
A1 EXPLANATION OF SYMBOLS	3
A2 CORRECT USE	3
A3 INSTALLED COMPONENTS	3
A4 CABLE GLANDS	4
A5 TRANSPORT AND STORAGE	4
<u>B) ASSEMBLY AND COMMISSIONING</u>	4
B1 SAFETY INSTRUCTIONS	4
B2 PREREQUISITES FOR ASSEMBLY/DISASSEMBLY	4
B3 WORKING STEPS DURING ASSEMBLY	5
<u>C) INSTALLATION</u>	5
C1 FIRST USE	5
C2 OPERATION	5
<u>D) OPERATING INSTRUCTIONS</u>	6
D1 SAFETY INSTRUCTIONS FOR OPERATION AND MAINTENANCE	6
D2 AUTOMATIC OPERATION	6
D3 TROUBLESHOOTING	6
<u>E) TECHNICAL DATA</u>	7
E1 DESIGN	7
E2 AS-INTERFACE	7
E3 POWER SUPPLY TO THE PERIPHERY	8
E4 INPUTS	9
E5 OUTPUTS	9
E6 WARNING	9
<u>F) ELECTRICAL CONNECTIONS</u>	10
<u>DECLARATION IN ACCORDANCE WITH EC DIRECTIVES</u>	11

You can find additional information and current addresses for our branches and trade partners at:





www.ebro-armaturen.com

EBRO ARMATUREN GmbH
 Karlstraße 8
 D-58135 Hagen
 ☎ (02331) 904-0
 Fax (02331) 904-111

A) General

A1 Explanation of symbols

Notes are indicated by the following symbols in these Instructions:

	<p>Absolute prohibitionmust be complied with</p>
 <p>XXXXX</p>	<p>Danger / Caution / Warning ... indicates a hazardous situation, which can result in death or severe injuries for people and/or damages in the pipe system.</p>
	<p>Note ... indicates an instruction that must be complied with.</p>
	<p>Information ... provides useful tips and recommendations</p>

Failure to observe these notes, cautions and warnings could give rise to dangers and invalidate the manufacturer's warranty.

A2 Correct use

The AS-i interface is used in combination with pneumatic linear actuators. It is used to signal the states "on/off" and for pneumatic control after having been fitted to a valve. The AS-i interface is equipped with proximity switches or mechanical limit switches depending on the specifications of the customer – terminal diagrams for typical position indicators can be found in Appendix D2.

The AS-i interface and its components correspond to the appropriate standards EN 60947-5-2, EN 60947-5-6, 73/23/EWG and 89/336/EWG, as well as EN 50295 and IEC62026. - See D1

The AS-i interface may not be operated until the following documents have been observed:

- <Manufacturer declaration on EC guidelines> ,
- These mounting/operating instructions, which are supplied with the product.

The switch box is not to be used in an environment that is susceptible to ⚡ dangers.

Failure to comply with this <Correct use> represents gross negligence and releases the manufacturer, EBRO Armaturen, from any product liability.

➔ The type plate should not be covered so that the installed valve remains identifiable.

A3 Installed components

The switch box is equipped with position detectors in accordance with the customer's requirements.

Any customisation of the switch box is only permissible after consultation with the manufacturer. The mounting instructions and safety instructions supplied by the manufacturer of these components are to be observed.

A4 Cable glands

When connecting cables and wires to operating equipment, cable glands must be used that are suitable for the respective type of cable/wire.

They must include a suitable sealing element in order to ensure that at least protection class IP 65 is maintained for the control. Metallic cable glands must be earthed.

Bore holes for cable glands that are not required must be closed with sealing plugs.



A5 Transport and storage

During storage and transport, the AS-i interface should be kept in the factory packaging and not unpacked until directly before its assembly into the pipe section.

B) Assembly and commissioning

	<p><i>These instructions contain safety instructions for foreseeable risks during the assembly/connection of the AS-i interface to a control system.</i></p> <p>It is the user's responsibility to supplement these instructions for other risks specifically linked to the location. It is assumed that all requirements for this system have been complied with.</p>
---	--



B1 Safety Instructions

	<p>Installation work and the electrical wiring may only be carried out by an authorised specialist.</p> <p>All tools and materials used must</p> <ul style="list-style-type: none"> - comply with the relevant regulations; - be in perfect working condition.
	<ul style="list-style-type: none"> • The function of a fitted AS-i interface must comply with the <Correct use>, which is described in Section A2. The conditions of use must comply with the specifications indicated on the type plate for the switch box. • Before beginning any installation work, the control medium must be properly shut down by the responsible operational department to avoid any injuries e.g. due to compressed air (disconnect).

B2 Prerequisites for assembly/disassembly

- Ensure that only those switch boxes are fitted that comply with the conditions of use. See the corresponding labelling on the type plate (*Section A4*).
- The specifications on the type plates are to be observed. Further technical information about the AS-i interfaces can be found in the sources given in Section A6 and on the product.
- Any upgrades to the components may only be carried out after consultation with the manufacturer. The wire connection is to be completed carefully so that the individual strands are not damaged.

- When connecting multiple or fine gauge wires, the wire ends need to be prepared.

	<p>The attachment of wire-end sleeves must always be carried out with the appropriate crimpers to ensure a consistent quality of compression. All terminal connections, including those that are not in use, are to be firmly tightened.</p>
	<p>The screw connections to the valve must be secured against working loose.</p>

B3 Working steps during assembly

- Inspect the AS-i interface for transport damage. Damaged interfaces must not be installed.
- For casings set up outdoors, special measures are to be taken, where necessary, to ensure correct operation. This includes, for example, using protective rain covers or, if required, protective casings with a sufficient protection class.
- Connection to the user-side control must be made in accordance with the planner's/user's specifications.

Identifiable system malfunctions must be resolved before commissioning. See also Section C3 <Troubleshooting>.

C) Installation

The EBRO switch box is usually delivered completely installed on EBRO pneumatic actuators. The sensors are adjusted in the factory to the "OPEN" and "CLOSED" settings of the valve. If the switch box is subsequently fitted then the sensors are to be installed in such a way that when the valve is closed the lower sensor is connected and switched to I1. When the valve is open, the upper sensor must be connected and switched to I2.

C1 First use

- The equipment should only be operated in an undamaged and clean state.
- All electrical connections to user-side control systems should be checked by a qualified electrician before being put into operation.

C2 Operation

Before commissioning the device, a functional inspection and approval process must be carried out by the responsible operating department. The switch box is only to be used for its intended purpose. Improper use and invalid types of operation endanger the operator and/or the upstream and downstream system parts.

D) Operating instructions

In accordance with the provisions of Directive 2006/42/EC, the planner of the system must draw up a comprehensive risk analysis.

The manufacturer EBRO Armaturen provides the following documents for this purpose:

- these mounting and operating instructions,
- the declaration on EC Directives included at the beginning.

	<p><i>These instructions include safety notices for foreseeable risks arising when using the AS-i interface in industrial applications.</i></p> <p>It is the planner's/operator's responsibility to supplement these instructions for other risks specifically linked to the system.</p>
---	--

D1 **Safety instructions for operation and maintenance**

 <p>Danger</p>	<ul style="list-style-type: none"> • The function of an AS-i interface must comply with the <Correct use>, which is described in Section A2. • The conditions of use must comply with the specifications shown on the type plate. • All necessary maintenance work to be carried out on the switch box is to be completed by qualified personnel only. For the purposes of this manual, qualified personnel are persons who, on the basis of their training, specialist knowledge and professional experience, can correctly assess and execute the work assigned to them and can identify and avoid potential risks. • The operator of an electrical plant is required to maintain the equipment properly, operate the equipment properly, to monitor it and carry out maintenance and repairs. • The specified safety regulations are to be observed during any maintenance or repair work.
---	--

D2 **Automatic operation**

If the switch box is connected to the user's control system as described in Section B/C then no further action is required. Section D1 <Safety instructions> is to be observed.

Maintenance: At suitable intervals, check whether the screw connections are OK.

D3 **Troubleshooting**

Type of problem	Countermeasure
Malfunction of electrical components and/or (feed) lines	If malfunctions in the electrical connections in/at the terminal box or its components are diagnosed these are to be corrected – in compliance with the information in Section D <Planning documents> – by qualified personnel.

E) Technical data

SWITCH BOX TYPE AT- AS-i- Linear 2.1

Control and feedback via AS-i for pneumatic linear actuators.
Bus communication and 24 V power supply via AS-i according to EN 50295
in a compact switch box for installation onto a pneumatic linear actuator.

The EBRO Switch Box Type AT- AS-i- Linear 2.1 includes an AS-i Slave with extended address mode according to version 2.1. The AS-i Slave has two digital inputs and one digital output. The power supply to the circuit board and the connected low power solenoid valve is provided via the AS-Interface.

Two external switch sensors capture the open/closed position and a solenoid valve serves to control a pneumatically operated valve.

The conductor paths are covered with a protective coating to protect against corrosion. The integrated Watchdog ensures that the solenoid valve is switched off in the event of a breakdown in the bus communication.

E1 Design

Body:	Polycarbonate with inspection window
Protection class:	IP 66
Ambient temperature:	-20 °C to +75 °C
Feedback:	external sensors
Signalling:	Open/Closed
Switch function	changeover contact
Solenoid valve:	3/2 way single acting or 5/2 way double acting (24 V via AS-i) 0.7 watts incl. connection cable (solenoid valve) and flat cable pick-off

E2 AS-Interface

AS-Interface profile:	S-7.A.E.
Inverse polarity protection:	yes
Display of AS-Interface	
Voltage:	yes LED 2 (green)
Display	
Data communication error:	yes LED 3 (red, continuous light)
Display of peripheral error:	yes LED 3 (red, blinking)
Operating voltage:	26.5...31.6 V
Total power consumption:	< 240 mA
Standby	
delay time:	< 1s
AS-Interface IC:	ASI4U
AS-Interface specification:	V2.1
AS-Interface certification:	applied for

The assignment of the binary input (cycle time: max. 10ms) and output (cycle time: max. 20ms) databits is given in the following table

Assignment of the data bits

Bits	Type	Description	Function
D0	Input	Sensor 1	Sensor position 1 switched (closed*)
D1	Input	Sensor 2	Sensor position 2 switched (open*)
D2	Output	Actuator	Switch output for solenoid valve

* The switching points can be freely selected. The preferred setting is indicated.

The parameters P0,... P3 are not used.

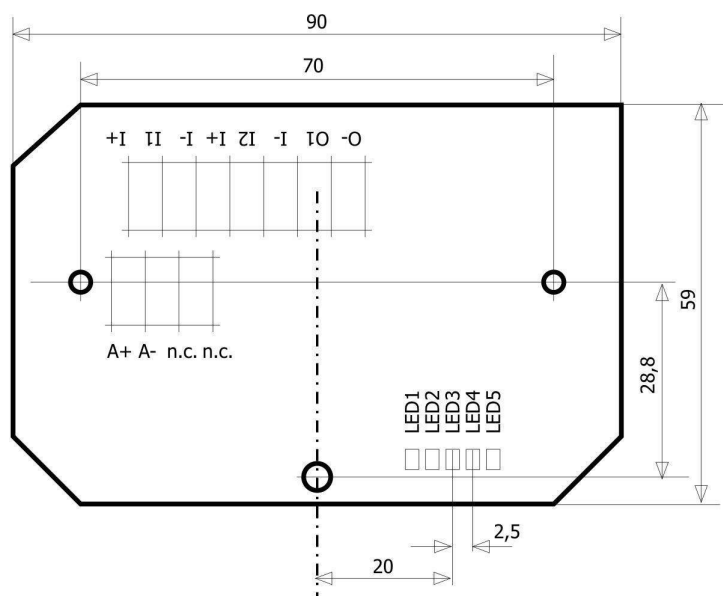

- I+: Sensor power supply (24V DC)
- I-: 0V for sensor power supply
- I1,... I2: Binary inputs
- O1: Binary output
- O-: 0V for switch output
- A+, A-: Connection to the AS-Interface network

The connections are made via cage clamp terminals, which accept conductor cross-sections in the range between 0.5mm² to 1.0mm².

E3 Power supply to the periphery

- Sensor power supply: from AS-Interface
- Nominal voltage: 24 V DC
- Voltage range (I+,I-) 17.5...30V DC (sum of all currents <200mA)

In the event of a short circuit or overload, the periphery power supply is protected by the current limiter. This means that the whole periphery power supply will be interrupted in the event of a short circuit of the sensor power supply or the output. This error is signalled to the Master by the periphery error bit (only profile S-7.A.*.0) and displayed locally via the red LED.

E4 Inputs

Sensor power supply:	from AS-Interface
Sum of all currents	< 100mA
Input circuit:	p-switching
Switching level	
High signal/Low signal:	>11V / ≤5V
Input power:	corresponds to IEC61131-2 type 2, max. 10mA
Display of switching status:	LED 5 (for I2) and LED 1 (for I1) (yellow)
Input delay:	<5 ms
Max. length of the	

Note: None of the connections I-, I+, Ix may be connected to an external potential or GND.

E5 Outputs

Actuator power supply:	from AS-Interface
Sum of all currents	< 100mA
Output circuit:	p-switching
Display of switching status:	LED 4 (yellow)
Short circuit protection:	yes
Overload protection:	yes
Induction protection:	yes, DC13 according to IEC60947-5-1
Limit:	< 200 mA

In the event of a short circuit, the output is current limited via the current limiter for the sensor and actuator power supply. This means that in the event of an output short circuit the sensor power supply will be interrupted. A short circuit to the output will therefore also be signalled to the Master by the periphery error bit.

The integrated Watchdog will switch off the current to the output if the AS-Interface communication is interrupted.

Note: None of the connections O1, O- may be connected to an external potential or GND.

E6 Warning

This is a Class A product. This product can cause radio interference in a residential area. In this case, it may be necessary for the user to take corresponding measures.

F) Electrical connections

The electrical wiring of the sensors and the solenoid valve has been done on the circuit board terminal block in the switch box in the factory (in the event of subsequent installation the sensors are to be connected according to Point 1).

CAUTION: The sensor power supply is provided via the AS-i network. Do not connect the inputs to external potentials.

The connection for the yellow AS-i line is made via the flat cable pick-up included in the delivery. Connections to the yellow AS-i flat cable:

Pin 1: AS-i +
Pin 3: AS-i -

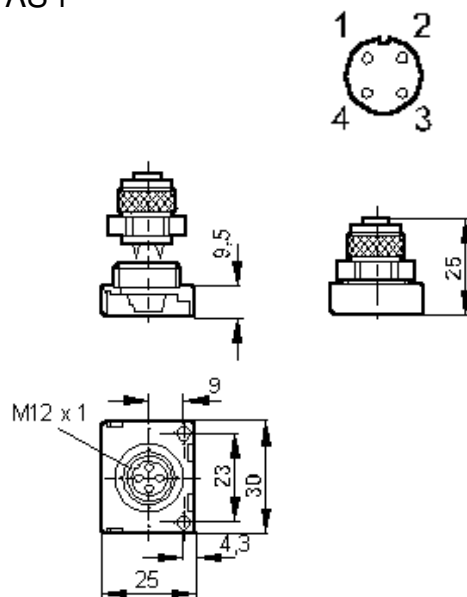

Declaration in accordance with EC Directives

The manufacturer

EBRO Armaturen

Gebr. Bröer GmbH
Karlstrasse 8
58135 Hagen
Germany

declares that the product

AT AS-i Interface for Linear Actuators V2.1

are manufactured in accordance with the requirements of the following standards:

EN 60947-5-2	Low-voltage switchgear and controlgear
EN 60947-5-6	
EN 50295	Low-voltage switchgear and controlgear - Controller and device interface systems - Actuator Sensor Interface (AS-i)
IEC62026	Low-voltage switchgear and controlgear - Controller-device interfaces (CDIs)

The following product documents are available:

Planning documents, Technical data sheets, catalogue sheets

These products comply with the directives specified below:

73/23/EWG	Low Voltage Directive
89/336/EWG	Electromagnetic compatibility (EMC)

Hagen, 4.12.2009



Dirk Mischnick, Managing Director