

Operating instructions - SBU Advanced

SBU Advanced

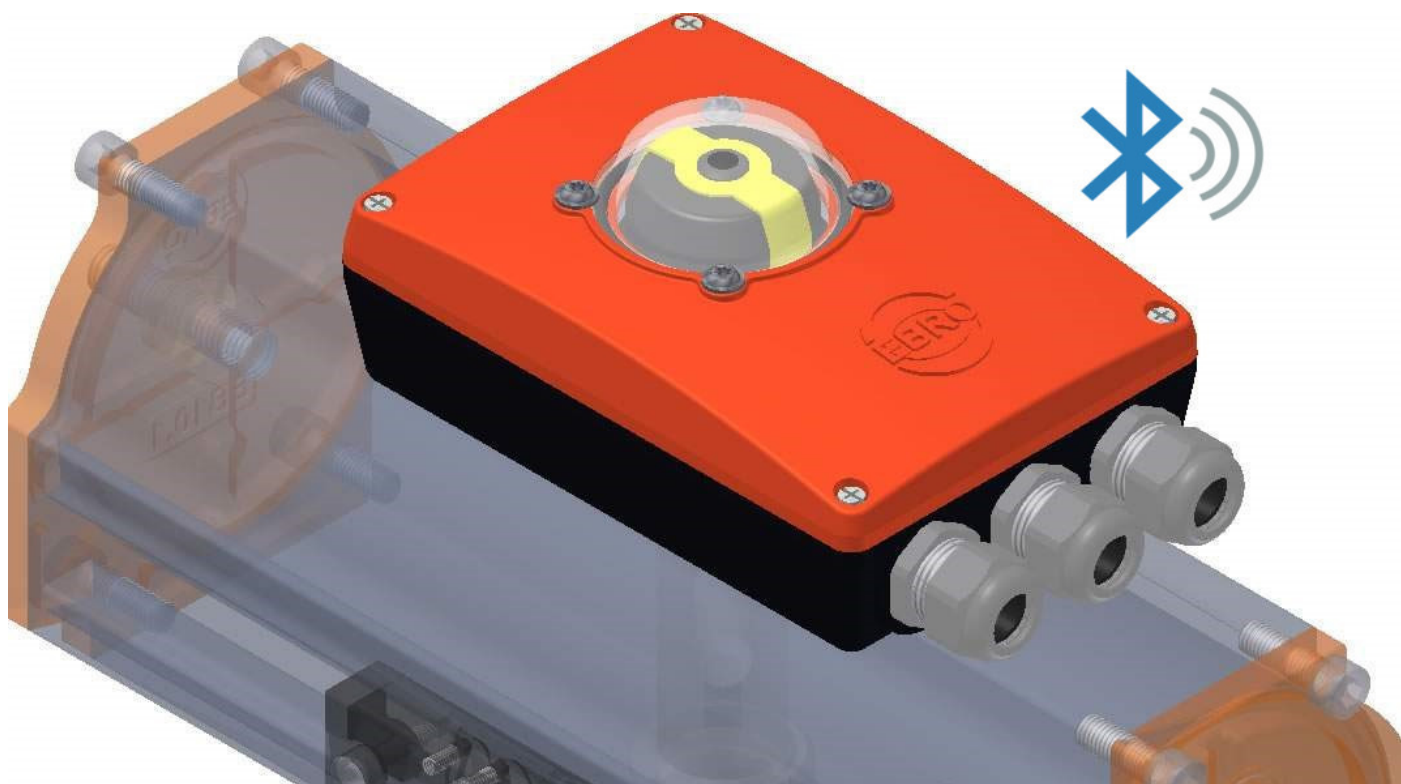

Example illustrations, not all possible type variants are shown!

Original assembly instructions with operating instructions and technical appendix

**in accordance with the EC RED Directive 2014/53/EU
in accordance with the EC EMC Directive 2014/30/EU
in accordance with the EC Machinery Directive 2006/42/EC**

English language version

Revision: 03-04.19

Table of contents

	Page
A) GENERAL INFORMATION	4
A01 OVERVIEW OF TYPES	4
A02 DESIGN OF THE HAZARD SYMBOLS	5
A04 TERMS USED	7
A05 ABOUT THESE OPERATING INSTRUCTIONS	7
A06 NOTE ON COPYRIGHT AND PROPERTY RIGHTS	8
A07 WARRANTY AND LIABILITY	8
A08 LEGAL CONDITIONS	8
A09 NOTES FOR THE OPERATING COMPANY	9
A10 QUALIFIED PERSONNEL	10
A11 INSTRUCTION AND TRAINING	11
A12 MARKING OF THE SBU ADVANCED	11
B) SAFETY INFORMATION	12
B01 GENERAL SAFETY INFORMATION	12
B02 USE FOR THE INTENDED PURPOSE	13
B03 ORGANISATIONAL MEASURES	15
B04 SAFETY INFORMATION FOR THE OPERATING PERSONNEL	15
B05 SAFETY INFORMATION FOR THE OPERATION OF THE SBU ADVANCED	16
B06 SAFETY INFORMATION FOR START-UP/SHUTDOWN, SERVICE AND MAINTENANCE	16
B07 SAFETY INFORMATION FOR WORKING ON THE ELECTRICAL SYSTEM	18
B08 RESIDUAL HAZARDS	20
B09 DANGER DUE TO FORESEEABLE MISUSE	21
C) USAGE CONDITIONS	22
C01 AMBIENT TEMPERATURES	22
C02 ENVIRONMENTAL CONDITIONS	22
C03 INSTALLATION CONDITIONS	22
D) STORAGE, PACKAGING AND TRANSPORT	23
D01 STORAGE	23
D02 PACKAGING	23
D03 TRANSPORT IN GENERAL	23
E) MOUNTING INSTRUCTIONS	24
E01 MOUNTING THE SBU ADVANCED ON THE QUARTER TURN ACTUATOR	26
E02 ELECTRICAL CONNECTION	27
E06 SETTING AND ADJUSTMENT OF THE END POSITION SIGNALLING	31
E07 DISMOUNTING THE SBU ADVANCED	32

F) TEST RUN AFTER INSTALLATION	34
F01 TEST RUN	34
G) PRODUCT DESCRIPTION	36
G01 USE FOR THE INTENDED PURPOSE	36
G02 SCOPE OF DELIVERY	37
H) SERVICE AND MAINTENANCE	38
H01 SERVICE AND MAINTENANCE IN GENERAL	38
H02 MAINTENANCE INTERVALS	40
H03 CLEANING OF THE SBU ADVANCED IN GENERAL	41
I) ERRORS, CAUSES AND REMEDIAL ACTION	42
I01 ERRORS IN GENERAL	42
I02 COLLECTIVE ERROR	43
I03 ERRORS – CAUSE – REMEDIAL ACTION	43
J) DISPOSAL	44
J01 ENVIRONMENTAL PROTECTION	44
K) SPARE PARTS	45
K01 SPARE PARTS IN GENERAL	45
K02 ORDERING SPARE PARTS	45
L) EBRO CONNECT	46
EC DECLARATION OF CONFORMITY	48

Additional information and current Original assembly instructions SBU Advanced as well as current addresses of our branch offices and trade partners can be found at:

www.ebro-armaturen.com

EBRO ARMATUREN Gebr. Bröer GmbH
Karlstraße 8
D-58135 Hagen
☎ +49 (0)2331 904-0
Fax +49 (0)2331 904-111

A) General information

A01 Overview of types

Type	Description
SBU Advanced	Switch box for the acquisition of state signals (0°/90° or closed/open) for use in zones not at risk of explosion.

Solenoid valve:

The solenoid valve connection serves as the terminal point. Only valves with a control voltage of 24 V DC (max. 5 Watt) are permitted for controlling the pneumatic actuator.

A02 Design of the hazard symbols

The hazard symbols are found next to the safety information that indicates particular hazards for persons or material assets. They are uniformly structured in these operating instructions and must be observed without fail.



General hazard



High voltage



Hand injuries



Explosion

Signal word

Meaning

DANGER

Indicates a directly threatening hazard that will lead to very serious personal injuries or even death if the instruction given is not followed precisely.

WARNING

Indicates a possibly hazardous situation that could lead to very serious personal injuries or even death if the instruction given is not followed precisely.

CAUTION

Indicates a possibly hazardous situation or unsafe, hazardous procedures that could lead to personal injuries or damage to the SBU Advanced or its surroundings.

Structure of the safety information

Signal word

Type and source of the hazard



Explanation

Hazard symbol

Measures to avert the danger

Observe the respectively mentioned safety information and be particularly careful in these cases! Also pass on all safety information to other users!

In addition to the notes in these operating instructions, the generally applicable safety and accident prevention regulations must be observed!

A03 Design of the information symbols

You will find the information symbols next to circumstances or activities that ensure the safe, proper and efficient handling of the SBU Advanced if observed. They are all uniformly structured in these operating instructions and must be observed.



Protective gloves



Eye protection

Symbol	Meaning
	This symbol indicates that electrical components and the SBU Advanced must be switched off and secured against being switched on again before service and maintenance.
	This symbol indicates special circumstances that ensure the safe, proper and efficient handling of the SBU Advanced if observed. All information should be followed in the interests of use of the SBU Advanced as intended. Also pass on all safety information to other users!
<ul style="list-style-type: none">•	Work and/or operation steps are marked by the bullet point. The steps must be performed in the order given from top to bottom!
	Components and their installation location inside the SBU Advanced are marked by the rectangular and round key and a letter. Note that the letters are issued again for each new chapter and always begin with A.





Information and symbols attached directly to the SBU Advanced such as warning signs, actuation signs, direction of rotation arrows, component markings, etc. must be observed without fail.

Information and symbols attached directly to the SBU Advanced must not be removed and are to be maintained in a fully legible state!

A04 Terms used

SBU Advanced

The term SBU Advanced is used in the following text for these incomplete machines for acquiring the signals of the 0° and 90° positions of valves actuated by pneumatic quarter turn actuators or linear actuators.

Operating personnel

The term operator is used in the following text for the operating personnel or the user of the SBU Advanced. This group of people has been trained on the SBU Advanced and informed about possible hazards.

A05 About these operating instructions

These operating instructions apply to the SBU Advanced in the standard version. The purpose of the SBU Advanced is to detect the end positions (0° and 90°) of the valves with the help of the actuation of pneumatic quarter turn actuators or linear actuators, to process them with microprocessor assistance and to make them available to an existing interface for further processing.

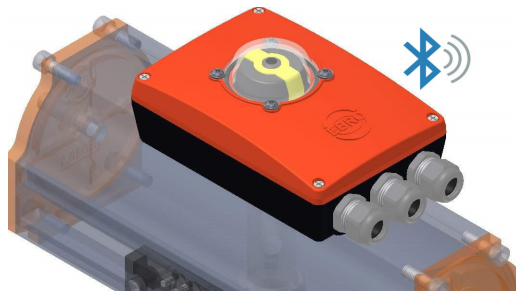

The SBU Advanced in the form delivered by EBRO ARMATUREN is an incomplete machine that is intended to be attached to a pneumatic quarter turn actuator with a VDE/VDI 3845 interface or optional detached for a linear actuator.

You must follow these operating instructions when operating the SBU Advanced.

These operating instructions are intended to be used for safe working on and with the SBU Advanced and are a considerable help for the successful and safe operation of the SBU Advanced.

They contain important information that will help you to operate the SBU Advanced safely, properly and economically and to use the full range of functions of the SBU Advanced. Observing them will help to avoid hazards, to reduce repair costs and downtimes and to increase the reliability and prolong the service life of the SBU Advanced.

In addition, the operating instructions are intended to enable the user to carry out maintenance and repair work on the SBU Advanced himself for daily use. They contain safety information that must be observed. All persons who work on and with the SBU Advanced must have the operating instructions to hand during their work and must observe the information and instructions relevant to them.

The operating instructions must always be complete and in a fully legible condition.

EBRO ARMATUREN Gebr. Bröer GmbH has compiled all the data in this documentation with the greatest of care. Despite that, EBRO ARMATUREN cannot rule out deviations and reserves the right to make technical modifications to the SBU Advanced without prior notice. EBRO ARMATUREN accepts no legal responsibility or liability for any damage that may occur as a result. Necessary changes will be included by EBRO ARMATUREN in subsequent editions.

A06 Note on copyright and property rights

No part of this documentation may be duplicated or made available to third parties without the special permission of EBRO ARMATUREN Gebr. Bröer GmbH. It may only be made available to authorised persons.

This documentation including all of its parts is protected by copyright. Duplication, translation and microfilming as well as storage and processing in electronic systems require the written consent of EBRO ARMATUREN Gebr. Bröer GmbH.

Infringements are punishable by law with obligatory compensation of damages.

All rights to the exercising of commercial property rights are reserved by EBRO ARMATUREN Gebr. Bröer GmbH.

A07 Warranty and liability

Warranty and liability are based on the contractually defined conditions. For the warranty terms, please refer to the Terms and Conditions of Sales and Delivery of EBRO ARMATUREN Gebr. Bröer GmbH. Notify EBRO ARMATUREN GmbH of warranty and guarantee claims in writing immediately after discovery of the defect or error. The guarantee or warranty lapses in all cases in which no liability claims can be made.

Liability and warranty claims lapse in the case of software modifications without the knowledge and consent of EBRO ARMATUREN Gebr. Bröer GmbH.

Illustrations and drawings serve the general exemplification and can differ from the SBU Advanced delivered.

EBRO ARMATUREN GmbH will accept no warranty claims for damage caused by use other than for the intended purpose, improper storage or improper transport.

A08 Legal conditions

The information, data and notes provided in the operating instructions were up to date at the time of going to print.

No claims arising from the data, illustrations and descriptions can be asserted for SBU Advanced units already delivered.

EBRO ARMATUREN Gebr. Bröer GmbH accepts no liability for damage and operational disruptions caused by:

- assembly.
- improper operation and troubleshooting during operation.
- maintenance (service, care, repair).
- improper use.
- unauthorised modifications to the SBU Advanced.
- improper working on and with the SBU Advanced.
- operating and setting errors.
- errors in the programming of the controller.
- disregard of existing standards, guidelines and accident prevention regulations.
- disregard of these operating instructions.

A09 Notes for the operating company

The operating company is any natural or legal entity that uses the SBU Advanced or on whose behalf the SBU Advanced is used.

The operating company is thus the entity responsible for safety.

The operating company or its authorised representative must ensure:

- that all relevant regulations, instructions and laws for the avoidance of accidents and for operational readiness are complied with.
- that, following the installation and connection of the SBU Advanced, the complete SBU Advanced conforms to the relevant directives and that the SBU Advanced conformity for the complex SBU Advanced is established.
- that the necessary protective devices are installed in conjunction with the on-site SBU Advanced.
- that only qualified personnel work on and with the SBU Advanced.
- that the personnel have the operating instructions at their disposal during all corresponding work and adhere to them.
- that unqualified personnel are forbidden to work on and with the SBU Advanced.
- that the necessary accident prevention and safety regulations are adhered to during the assembly or maintenance work on the SBU Advanced.

The operating instructions are to be supplemented by the operating company on account of national regulations for accident prevention and environmental protection, including information on supervising and reporting duties for taking into account special operational conditions, e.g. with regard to work organisation, work processes and the assigned personnel.

In addition to the operating instructions and the mandatory accident prevention regulations applicable in the user's country and at the place of use, the recognised technical rules and/or state of the art for occupational health and safety are to be complied with.

A10 Qualified personnel

Qualified personnel are persons who, on account of their training, experience, instruction and knowledge, are able to carry out the necessary activities on the SBU Advanced. In particular they have knowledge of relevant standards, provisions, accident prevention regulations and operating conditions and have been authorised by the entity responsible for the safety of the SBU Advanced to carry out the respectively necessary work. They must be capable of recognising and avoiding possible hazards.

Semi-skilled personnel trained by EBRO ARMATUREN GmbH may work with the SBU Advanced. In addition, they may instruct other persons in the operation and mode of operation of the SBU Advanced. Otherwise, special knowledge is required for certain tasks and activities. These may only be carried out by trained and skilled workers.

Activities	Instructed persons	Instructed persons with technical training	Electricians	Manufacturer
Installation / setup		•	•	
Initial commissioning		•	•	
Operation	•			
Troubleshooting mechanical		•		
Troubleshooting electrical				•
Cleaning	•			
Maintenance		•	•	
Work on the electrical system			•	
Packaging and transport	•			

A11 Instruction and training

It is your duty as the operating company to inform the operating and maintenance personnel or instruct them about existing safety and accident-prevention regulations as well as about the safety devices existing on the SBU Advanced.

The different technical qualifications of the employees are to be taken into account.

The operating personnel must have understood the instruction. In addition, it must be ensured that attention is paid to the instruction. Only in this way can safety and hazard-conscious working of your personnel be achieved. This should be checked regularly. As the operating company you should therefore have participation in the instruction or training confirmed in writing by each employee.

If there is still a need for training of the operating personnel after handover of the SBU Advanced to the operating company, please contact EBRO ARMATUREN Gebr. Bröer GmbH to discuss the conditions.

A12 Marking of the SBU Advanced

Each SBU Advanced is marked with the following data on the housing or on the type plate:

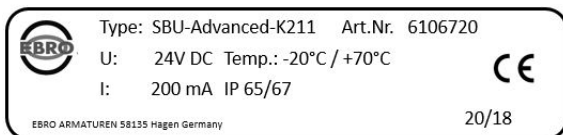

Example of an SBU Advanced standard version (outside of a potentially explosive zone)

The type plate describes the temperature range, electrical data, EBRO article no. and IP protection class applying to the SBU Advanced. In addition, the date of manufacture and the CE mark are also printed on it. So that the installed SBU Advanced remains identifiable, it should not be covered.

B) Safety information

B01 General safety information

These instructions contain safety information on the foreseeable risks involved in the mounting, connection, operation and dismounting of the SBU Advanced.

It is the responsibility of the operating company to supplement this information to cover other, specifically local or process-related risks.

Please contact EBRO ARMATUREN Gebr. Bröer GmbH in case of questions or problems.

The SBU Advanced conforms to the state of the art at the time of delivery and is deemed to be an incomplete machine within the meaning of the Machinery Directive.

The SBU Advanced can be a source of danger to persons, the SBU Advanced itself and other material assets of the operating company if:

- personnel who are unqualified and have not been instructed work on and with the SBU Advanced.
- the SBU Advanced is used improperly and not for its intended purpose.
- the SBU Advanced is incorrectly adjusted, repaired, maintained or connected.

The SBU Advanced must be adjusted and equipped such that, when properly adjusted and equipped and used for its intended purpose in error-free operation, it fulfils its function and does not represent a danger to individuals. Take suitable measures to ensure use for the intended purpose. Operate the SBU Advanced only if it is in perfect condition. Retrofits, modifications or conversions of the SBU Advanced are forbidden as a matter of principle and require consultation with EBRO ARMATUREN Gebr. Bröer GmbH in every case.

B02 Use for the intended purpose

The SBU Advanced serves to acquire the signals for the 0°/90° or closed/open position detection of a valve. The SBU Advanced is mounted on a pneumatic quarter turn actuator with a VDE/VDI 3845 AA2 interface. Quarter turn actuators not having these interfaces require an additional attachment kit for adaptation. The SBU Advanced can also optional be used as a detached unit with linear actuators. The additional interface for two 24 V DC proximity switches allows the two end position sensors of the linear actuator to be electrically connected there and their signals processed by the microprocessor-assisted SBU Advanced. The SBU Advanced is suitable only for the non-explosive zone and may be operated only with a 24 V DC power supply. The further conditions of use are described in more detail in the chapter *Usage conditions*. The SBU Advanced may only be put into operation after the following documents have been read:

- <Explanation of the EU directives>
- These assembly/operating instructions

DANGER



Danger due to use of the SBU Advanced other than for the intended purpose

People can be seriously injured if the SBU Advanced is used improperly or for a purpose other than that intended. Also, the SBU Advanced may sustain damage.

Use the SBU Advanced only for its intended purpose!

Do not modify the SBU Advanced!

Do not exceed the operating voltage!

INFO



Be sure to observe all the information in these operating instructions, in particular the safety information. It must be read and observed before all activities on the SBU Advanced.

Any use, adjustment and variation other than that described in these operating instructions is considered to be improper and contrary to the intended purpose of the SBU Advanced!

This EBRO-SBU Advanced, which

- a) will be installed as a complete functional unit in a complete system
 - directly on a pneumatic quarter turn actuator with the attached interface according to VDI/VDE 3845 AA2 80 mm x 30 mm and 30 mm (max. dia. 30 mm) shaft height,
- b) should normally detect the 0° (closed) and 90° (open) positions.
- c) The microcontroller-assisted switch box has the following interfaces:
 - Terminal point for a 24 V DC solenoid valve
 - Terminal point for two external sensors
 - Terminal point for the closed/open feedback signals
 - Terminal point for a collective error
 - Bluetooth 4.0 LE interface for the visualisation of the operating state and parametrisation options.

B03 Organisational measures

The SBU Advanced has been designed and built in accordance with the state of the art and recognised safety rules. In order to avoid danger to the users and impairment of the SBU Advanced and other material assets, the following organisational measures are to be adhered to:

- observance of the intended purpose of use of the SBU Advanced.
- operation of the SBU Advanced in a technically flawless condition.
- assignment of sufficiently qualified personnel.
- adherence to the maintenance intervals.
- observance and adherence to the hazard signs and markings on the SBU Advanced.
- observance of these operating instructions.

The operating instructions are to be stored permanently and ready to hand near the SBU Advanced. The personnel assigned to carry out tasks on the SBU Advanced must have read the operating instructions, in particular the chapter "Safety information", before starting work. This applies in particular to personnel who only work occasionally on the SBU Advanced.

Spare parts must meet the technical requirements attained during the commissioning of the SBU Advanced. This is guaranteed with original spare parts from EBRO ARMATUREN Gebr. Bröer GmbH. The environment of the SBU Advanced must be kept tidy and clean. Dirt and hampering of the function of the SBU Advanced as well as restrictions in the freedom of movement of the user can lead to errors and accidents.

The SBU Advanced may be operated only by personnel with the appropriate qualifications.

It is the duty of the operating personnel to check the SBU Advanced at regular intervals (at least once per day) for outwardly visible damage and defects. Any changes that occur that are detrimental to safety, including changes in the operational behaviour, must be reported and rectified immediately.

B04 Safety information for the operating personnel

The SBU Advanced may only be used in a technically flawless condition as well as for its intended purpose, in a safety and hazard-conscious manner and in accordance with these operating instructions! All faults, especially those that could affect safety, must be rectified immediately!

Each person assigned to the installation, commissioning, operation or maintenance of the SBU Advanced must have read and understood these operating instructions in their entirety – in particular the chapter *Safety information* – before starting work. This especially applies to personnel who only occasionally work on the SBU Advanced.

No liability will be accepted for damage and accidents that occur due to disregarding the operating instructions.

The relevant accident prevention regulations as well as the other generally recognised safety rules and rules of occupational medicine must be followed.

The responsibilities for the various activities in the context of the operation, service and maintenance of the SBU Advanced must be clearly defined and adhered to. Only in this way can human errors be avoided, in particular in dangerous situations.

The operating company must obligate the operating and maintenance personnel to wear personal protective equipment. This includes in particular safety shoes, protective gloves, safety glasses, protective clothes and, if necessary, ear protection and close-fitting work clothes.

Do not wear long hair hanging loose, loose clothing or jewellery! There is a fundamental risk of injury due to being caught up, pulled in or dragged by moving parts!

If you discover safety-relevant changes to the operational behaviour of the SBU Advanced or faults in the SBU Advanced, it must be shut down immediately and the occurrence is to be reported to the responsible person!

First aid facilities such as first aid kits, eyewash bottles, fire extinguishers, etc. are to be kept within reach! Work may only be carried out on the SBU Advanced by reliable, qualified personnel. The legal minimum age must be observed!

Assign only trained or instructed personnel!

Personnel undergoing training, instruction or general education as well as apprentices may only work on the SBU Advanced under the constant supervision of an experienced, qualified person!

B05 Safety information for the operation of the SBU Advanced

For all work that concerns the operation, retooling or adjustment of the SBU Advanced and its safety devices, as well as its inspection, maintenance and repair, the switch-on and switch-off procedures according to these operating instructions and the information on maintenance must be observed!

The SBU Advanced may only be put into operation in the assembled and ready-to-operate condition.

The SBU Advanced is suitable only for operation in areas that are not at risk of explosion!

Before starting work, the personnel must familiarise themselves with the working environment around the SBU Advanced.

The SBU Advanced must be checked for outwardly visible damage at regular intervals (at least once per day). Changes (including in the operational behaviour) must be reported immediately to the responsible foreman or the works manager.

Shut down and secure the SBU Advanced immediately in case of malfunctions. Have malfunctions rectified immediately by technical personnel who are trained for such work.

B06 Safety information for start-up/shutdown, service and maintenance

The operating personnel must be informed before special work and maintenance are carried out.

The prescribed intervals or those specified in the operating instructions for recurring checks, service or maintenance must be adhered to.

Workshop equipment appropriate for the work is absolutely essential for carrying out the service and maintenance tasks.

If necessary, illuminate service and maintenance areas with additional hand lamps or lamps mounted on stands.

Secure the maintenance area if necessary!

To avoid electric shocks, do not touch any electrical components or damaged, torn and in particular live parts.

During the setting and adjustment work, the support shaft with the end position cams and the remote position indicator may rotate. Therefore, safe working on the SBU Advanced must be ensured. An appropriate safe distance must always be maintained.

Check the seals of the electrical housing regularly and replace them if necessary.

Clean the SBU Advanced and its surroundings at regular intervals.

Screwed connections loosened during maintenance and repair work must always be tightened again afterwards!

Do not stand or work under suspended loads.

If carrying out work at heights of 1.60 m or higher, safe climbing aids and working platforms or other such equipment provided for this purpose are to be used! In the case of work platforms or work at heights greater than 1.0 m, appropriate fall protection must be provided! Keep all grips, steps, railings, landings, platforms and ladders free from dirt!

At the start of service, maintenance and care, free the SBU Advanced from all dirt and residues such as oil, operating materials or care products.

Do not use aggressive or solvent-based cleaning agents. Use lint-free cleaning cloths.

Use only water-based cleaning agents and observe the manufacturer's instructions. Do not use organic solvents as there is a risk of fire and explosion!

Ensure safe and environmentally-friendly disposal of operating and auxiliary materials!

DANGER

Danger due to rotating components.



Very serious injuries due to being crushed, pulled in, caught up or trapped as well as due to abrasion, grazing and cutting.

Assembly, disassembly, setting and adjustment work may be carried out only by technical personnel.

A safe distance must be maintained to rotating parts.

Observe the accident prevention regulations.

DANGER

Danger to life due to high voltage.



Very serious injuries due to electrocution.

The SBU Advanced may only be connected by an electrician.

Switch the SBU Advanced off and secure it against being switched on again.

B07 Safety information for working on the electrical system

The operating voltage required for the system may result in very serious injuries or even death if live parts are touched. If a short circuit occurs there is a danger of sparks being generated, leading to a fire.

The system connection must be adequately dimensioned in order to prevent overloads. Switch the SBU Advanced off immediately in case of faults in the electricity supply.

It is forbidden to work on live active parts of the SBU Advanced.

The SBU Advanced must be in a safe condition and is to be kept in this condition. The SBU Advanced must be inspected regularly. Defects such as loose connections, etc. must be reported and rectified immediately. The switch box is to be kept closed at all times. Only authorised personnel are allowed access to it for inspection and maintenance.

The SBU Advanced must be protected against indirect contact in accordance with its voltage, type of use and place of operation so that protection against hazardous contact voltages exists in the case of a fault in the SBU Advanced.

DANGER

Danger to life due to high voltage.



Very serious injuries or death due to electrocution or effects on medical implants.

Risk of falling due to electric shock.

The SBU Advanced may only be connected by an electrician.
Switch the SBU Advanced off and secure it against being switched on again.

Electrostatic charging may occur due to friction of the media in the pipeline and due to the possibly high pressures. This charging can adversely affect the SBU Advanced. The SBU Advanced must therefore be adequately earthed.

WARNING

Operational malfunction due to electrostatic charging.



Malfunctions of, or damage to components.

The SBU Advanced may only be connected by an electrician.

The SBU Advanced must be earthed.

DANGER

Danger due to rotating components.



Very serious injuries due to being crushed, pulled in, caught up or trapped as well as due to abrasion, grazing and cutting.

Assembly, disassembly, setting and adjustment work may be carried out only by technical personnel.

A safe distance must be maintained to rotating parts.

Observe the accident prevention regulations.

NOTE

Use personal protective equipment.



When dealing with hazardous materials, the personal protective equipment specified in the safety data sheets must be used.

Use the personal protective equipment.



B08 Residual hazards

The hazards emanating from the SBU Advanced occur when working inside the actual limits of the SBU Advanced if you have to put the SBU Advanced into operation for work, e.g. in the case of:

- maintenance.
- retooling.
- fault-finding and troubleshooting.

When carrying out service work, retooling or maintenance in which you have to put the SBU Advanced into operation, enlist the help of a second person who can switch the SBU Advanced off in an emergency.

Work with extreme care and attentiveness.

A residual risk remains when operating the SBU Advanced even when all safety regulations are followed. All persons who work on and with the SBU Advanced must be aware of the residual risks and follow the instructions designed to prevent these residual risks leading to accidents or damage.

DANGER

Danger due to missing safety devices.

Very serious injuries due to moving components.



If safety devices have to be dismantled or disabled for setup and tooling work, all work must be carried out with deliberation and care!

Any kind of routine in the operating sequence is to be avoided!

B09 *Danger due to foreseeable misuse*

It is the responsibility of the operating company to ensure that the SBU Advanced is used for its intended purpose by protecting it against foreseeable misuse and considering this in the safety consideration of the entire machine.

- It is forbidden to operate the SBU Advanced outside of the minimum or maximum operating conditions with regard to temperature, atmosphere and voltage.
- Operation with the switch box open is forbidden.
- Operation with modified actuating elements for signalling the end positions is forbidden.
- The disconnection of live contact and plug connections is forbidden.
- The SBU Advanced must not be disconnected from the earthing system.

DANGER

Danger due to misuse.



Very serious injuries due to moving components.

Assembly, disassembly, setting and adjustment work may be carried out only by technical personnel.



A safe distance must be maintained to rotating parts.

Very serious injuries or death due to electrocution.

The SBU Advanced may only be connected by an electrician.

The SBU Advanced must be earthed.

C) Usage conditions

C01 Ambient temperatures

Ambient temperature in area of use: -20 °C to +70 °C

Trouble-free operation of the SBU Advanced is guaranteed within this temperature range.

The mode of operation can no longer be guaranteed at temperatures above and below the temperatures specified above.

C02 Environmental conditions

Provided the individual components are assembled correctly, the SBU Advanced attains a protection class according to DIN of IP65/IP67/IP68.

Environmental media, in particular chemically aggressive media, can attack seals, hoses, cables and plastic.

C03 Installation conditions

The SBU Advanced should be mounted only in an area that meets the requirements for the temperatures and environmental conditions. The general directives for workplaces are also to be complied with. The SBU Advanced is not suitable for potentially explosive areas.

D) Storage, packaging and transport

D01 Storage

If you do not install the SBU Advanced immediately, ensure suitable storage conditions in dry, dust-free, frost-free indoor rooms protected against sunlight. Wrap the SBU Advanced in cardboard, plastic or film packaging.

In order to keep the unused SBU Advanced in a functional condition even over a maximum period of six months, please observe the following storage conditions:

- the storage room should be dry and free from dust.
- the storage temperature should be between + 5 °C and + 40 °C.
- the SBU Advanced should be stored on a level floor.
- the SBU Advanced should be protected against inadvertent movements and damage.
- the SBU Advanced should be protected against static discharge.

D02 Packaging

The complete SBU Advanced from EBRO ARMATUREN Gebr. Bröer GmbH is packed safely and fit for purpose in accordance with the transport route and destination.

INFO



Note.

On arrival at the destination the completeness of the shipment must be checked immediately against the shipping documents and packing lists; the intactness of the shipment must also be checked.

EBRO ARMATUREN Gebr. Bröer GmbH is to be notified immediately in case of complaints.

D03 Transport in general

Unless agreed otherwise, the SBU Advanced will be delivered fully factory-preassembled by EBRO ARMATUREN Gebr. Bröer GmbH.

For the transport, observe the specified weights and dimensions in the delivery documents of the SBU Advanced.

The SBU Advanced should be kept in the factory packaging until use or installation. The specified storage conditions must be adhered to.

DANGER

Danger due to incorrect transport or incorrect attachment.



Very serious damage to the SBU Advanced.

Do not suspend the SBU Advanced on attachment devices as there are no attachment points for this.

Ensure safe manual transport of the SBU Advanced.

Keep the SBU Advanced in the original factory packaging until reaching the place of use.

E) Mounting instructions

When mounting the SBU Advanced, the safety information in these operating instructions and the safety regulations applicable at the operating company's place of installation must be observed. The mounting or installation location must have a sufficient load-bearing capacity and should be free from vibrations.

The SBU Advanced should be mounted only in an area that meets the requirements for the temperatures and environmental conditions. The general directives for workplaces are to be complied with. Also observe the installation conditions specified in these operating instructions.

The SBU Advanced is assembled and adjusted in the factory for the purpose of use that you ordered. This purpose of use thus also corresponds to the intended purpose of use of the SBU Advanced.

Before installing the SBU Advanced, the intended purpose of use must be compared once again with the installation situation. The installation must be approved by the operating company and may only be carried out by qualified personnel.

The actuation of the SBU Advanced is only permitted when it is fully mounted on a pneumatic quarter turn actuator.

DANGER

Danger of the upper limbs being crushed.



Very serious injuries when actuating the SBU Advanced if it is not fully mounted on a depressurised pneumatic quarter turn actuator.

Before switching on the SBU Advanced, all components and connections must be fully mounted by qualified personnel.

The quarter turn actuator should be depressurised and secured against uncontrolled actuation.

Proceed with the utmost caution when installing the SBU Advanced and avoid damage to its components.

DANGER

Danger due to damaged components.



Very serious injuries due to moving components.

Very serious injuries or death due to electrocution.



Operating instructions - SBU Advanced

The operating company must ensure that the SBU Advanced and the pipework or quarter turn actuator are earthed via a secure earth connection to an earthing point. This particularly applies where insulating seals and screw connections made of non-conductive materials are used.

The bleeder resistance must be $< 10^6 \Omega$.

The operating company must ensure that the SBU Advanced is connected via an electrostatically conductive pipe connection or via a separate earthing point.

WARNING

Operational malfunction due to electrostatic charging.



Malfunctions of, or damage to components.

The SBU Advanced may only be connected by an electrician.

The SBU Advanced must be earthed.

E01 Mounting the SBU Advanced on the quarter turn actuator

The SBU Advanced is suitable for direct mounting on quarter turn actuators with the mounting interface according to VDI/VDE 3845 AA2 80 mm x 30 mm, shaft height 30 mm (max. dia. 30 mm). Adapters are required for all other interfaces. The SBU Advanced may only be operated with the accessories foreseen and approved by EBRO ARMATUREN Gebr. Bröer GmbH.

DANGER

Risk of injury in case of improper mounting.



Mounting may only be carried out by authorised technical personnel using suitable tools!

Risk of injury due to inadvertently switching on the plant and uncontrolled restarting.

Secure the plant against inadvertent actuation.
Ensure controlled restarting after mounting.

The SBU Advanced should be mounted as follows:

- Unpack the SBU Advanced from the factory packaging at the installation location.
- Check the SBU Advanced for transport damage.
- Check the SBU Advanced for damage.
- In case of outdoor installation of SBU Advanced units, measures may need to be taken to ensure operation as intended. These include the "Diaphragm element" option for switch box ventilation or rain roofs and possibly enclosures of an adequate protection class.
- Determine the mounting position of the device (parallel to the actuator).
- Open the switch box cover.
- Align the drive shafts (groove) and switch box shaft (tongue).
- Check the flush fitting of the insert seals on the underside of the switch box housing.
- Push the switch box onto the drive shaft.
- Fasten the switch box to the actuator with 4 cheesehead screws and spring washers.
- Close the switch box cover again if the electrical connection is not to be made immediately.

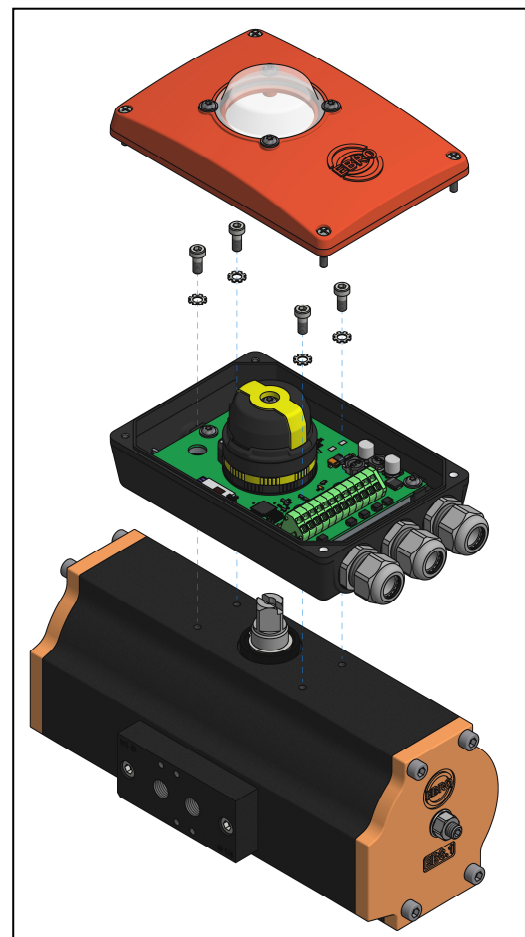

E02 Electrical connection

Switch the SBU Advanced off and secure it against being switched on again! Connect the electrical supply cables in the control box, observing the terminal assignment in the circuit diagram.

Connect all connections according to the legal regulations and the VDE directives.

Make sure that cable cross sections and fuses are adequately dimensioned in accordance with the power consumption.

Metallic cable glands must be connected to the earthing system. Unused holes for cable glands must be sealed with blanking plugs.

The attachment of wire end ferrules must always be done with suitable crimping tools to ensure constant quality of the crimping.

Measures may need to be taken against external influences if the SBU Advanced is installed outdoors.

These could be, for example, rain roofs or an enclosure. It is the duty of the company operating the SBU Advanced to check this.

The potential equalisation of the SBU Advanced takes place via the piping or via one of the three fixing screws of the PCBs.

Only separate cable glands suitable for the application may be used for the cable entries. Connecting threads in the switch box that are not required are sealed with suitable separately certified screw plugs.

The installation and maintenance may only be carried out by an **electrician**; refer here in particular to the chapter "Safety".

DANGER

Danger to life due to high voltage.



Very serious injuries or death due to electrocution.

The SBU Advanced may only be connected by an electrician.

Switch the SBU Advanced off and secure it against being switched on again.

Electrostatic charging may occur due to friction of the media and due to the possibly high pressures. This charging can adversely affect the SBU Advanced. The SBU Advanced must therefore be adequately earthed.

WARNING

Operational malfunction due to electrostatic charging.



Malfunctions of, or damage to components.

The SBU Advanced may only be connected by an electrician.

The SBU Advanced must be earthed.

The operating company must therefore ensure that the SBU Advanced and the pipework or quarter turn actuator are earthed via a secure earth connection to an earthing point. This particularly applies where insulating seals and screw connections made of non-conductive materials are used.

The bleeder resistance must be $< 10^6 \Omega$.

The operating company must ensure that the SBU Advanced is connected via an electrostatically conductive pipe connection or via a separate earthing point.

Terminal assignment

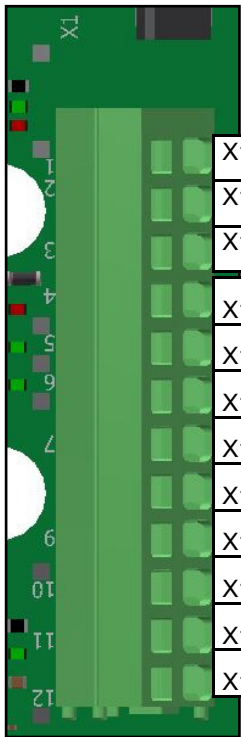

X1.1	PE
X1.2	GND
X1.3	+24 V DC ±10%

X1.4	Collective error
X1.5	Valve is OPEN
X1.6	Valve is CLOSED
X1.7	PE
X1.8	PE
X1.9	Valve GND
X1.10	Valve GND
X1.11	Valve +24 V DC (max. 5 W)
X1.12	Valve +24 V DC (max. 5 W)

Terminal	Customer connection
X1.1	PE
X1.2	Power supply GND
X1.3	Power supply +24 V DC
X1.4	
X1.5	
X1.6	
X1.7	PE
X1.8	
X1.9	Valve power supply GND
X1.10	
X1.11	Valve power supply +24 V DC
X1.12	
X2.1	Sensor power supply GND
X2.2	Sensor power supply +24 V DC
X2.3	Sensor 2 input
X2.4	Sensor 1 input

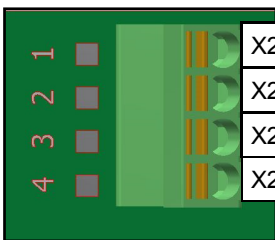

X2.1	GND
X2.2	+24 V DC
X2.3	Sensor 2
X2.4	Sensor 1

LED signalling

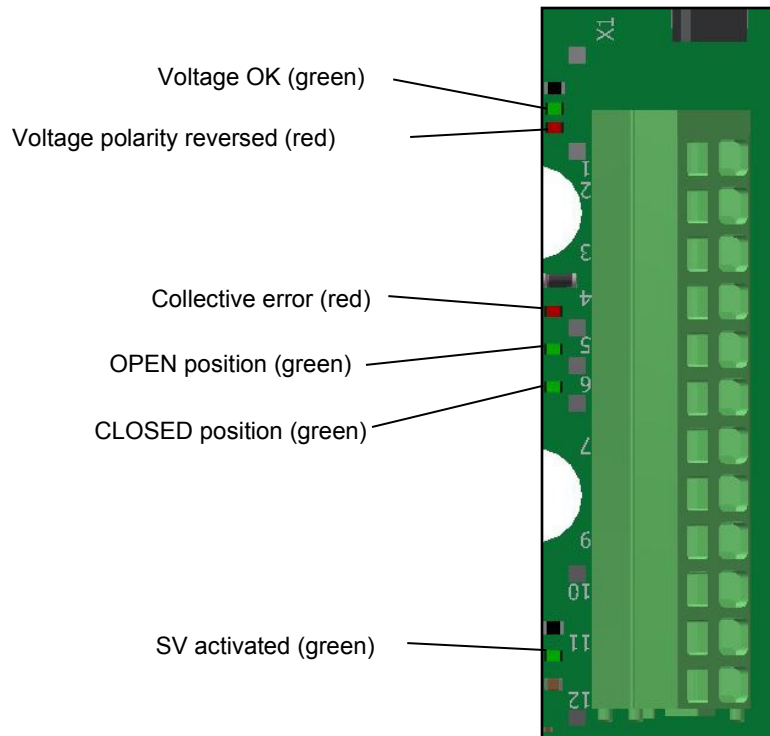

Connection of the operating company's signal cables

Operating voltage:

Terminal	Assignment	Signal
X1.1	Potential equalisation	PE
X1.2	Operating voltage -	GND
X1.3	Operating voltage +	+ 24 V DC \pm 10% max. residual ripple 10%

Signal outputs:

Terminal	Assignment	Signal
X1.4	Switching output – collective error	+ 24 V DC referenced to GND (max. 300 mA)
X1.5	Switching output – valve is OPEN	+ 24 V DC referenced to GND (max. 300 mA)
X1.6	Switching output – valve is CLOSED	+ 24 V DC referenced to GND (max. 300 mA)

Valve

Terminal	Assignment	Signal
X1.7	Potential equalisation	PE
X1.8	Potential equalisation	PE
X1.9	Solenoid valve power supply GND	GND
X1.10	Solenoid valve terminal point GND	GND
X1.11	Solenoid valve signal +	+24 V DC
X1.12	Solenoid valve terminal point + (max. 5 W)	+24 V DC

Signal inputs (optional):

Terminal	Assignment	Signal
X2.1	Sensor supply -	referenced to operating voltage GND
X2.2	Sensor supply +	+ 24 V DC referenced to GND (max. 200 mA)
X2.3	Switching input – valve is OPEN	+ 24 V DC switching input
X2.4	Switching input – valve is CLOSED	+ 24 V DC switching input

Jumper

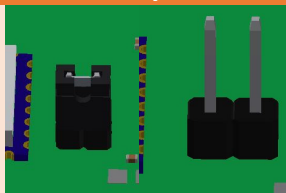
Jumper	+3.3 V reference for	Set	Not set
	Power supply for Bluetooth module	Bluetooth module active	Bluetooth module inactive

E06 Setting and adjustment of the end position signalling

During the setting and adjustment work, the support shaft with the end position cams and the remote position indicator may rotate. An appropriate safe distance must always be maintained.

DANGER



Danger due to rotating components.

Very serious injuries due to being crushed, pulled in, caught up or trapped as well as due to abrasion, grazing and cutting.

Assembly, disassembly, setting and adjustment work may be carried out only by technical personnel.

A safe distance must be maintained to rotating parts.

Observe the accident prevention regulations.

The setting and adjustment work may only be carried out by **instructed persons who have received technical training**; refer here in particular to the chapter "Safety".

DANGER



Danger to life due to high voltage.

Very serious injuries or death due to electrocution.

The SBU Advanced may only be connected by an electrician.

Switch the SBU Advanced off and secure it against being switched on again.

The actuation rings of the SBU Advanced are adjusted as follows:

- Close the valve or move the quarter turn actuator to the CLOSED position.
- Loosen the fixing screw (1).
- Adjust the black actuation ring (6) on the support shaft (7) so that the actuation magnet is placed directly above the sensor. When the power supply is connected the "closed" LED lights up.
- Open the valve or move the quarter turn actuator to the OPEN position.
- Adjust the yellow actuation ring (5) on the support shaft (7) so that the actuation magnet is placed directly above the sensor. When the power supply is connected the "open" LED lights up.
- Push the spacer ring (4) onto the support shaft (7).
- The cap (3) must be placed on the support shaft (7) such that it fits over the square of the shaft.
- Engage the position indicator (2) in the cap so that the indicator position corresponds to the position of the butterfly disc.
- Tighten the fixing screw (1).

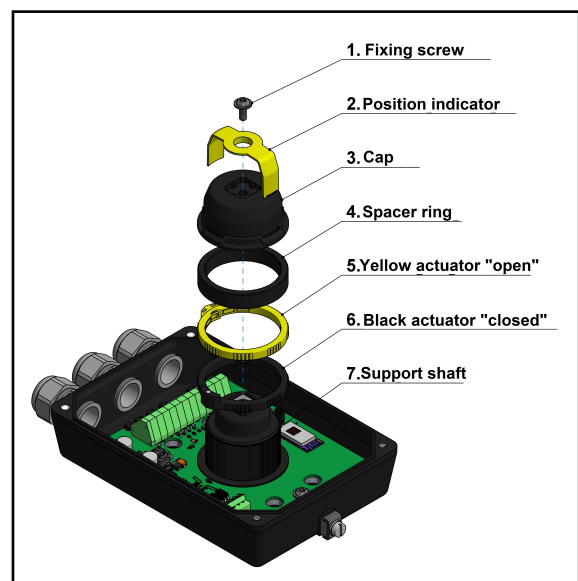
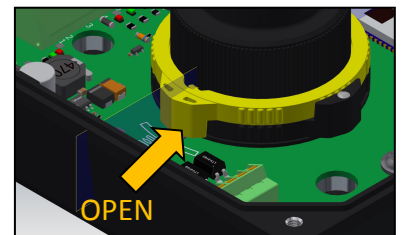

E07 Dismounting the SBU Advanced

When dismantling the SBU Advanced, the safety information in these operating instructions and the safety regulations applicable at the operating company's place of installation must be observed.

The removal must be approved by the operating company and may only be carried out by qualified personnel.

Proceed with the utmost caution when removing the SBU Advanced and avoid damage to its components. The SBU Advanced should be dismantled as follows:

- Take the SBU Advanced out of service, switch it off and secure it against being switched on again!

NOTE



Switch the SBU Advanced off and secure it against being switched on again for all work, before service, during adjustment and maintenance.

Depressurise the pneumatic quarter turn actuator and secure it against being pressurised.

DANGER



Danger to life due to high voltage.

Very serious injuries or death due to electrocution.

The SBU Advanced may only be connected by an electrician.

Switch the SBU Advanced off and secure it against being switched on again.

DANGER



Danger due to uncontrolled start-up of the pneumatic quarter turn actuator.

Very serious injuries due to incorrectly connected pneumatic quarter turn actuator or uncontrolled start-up.



Very serious injuries due to being crushed, pulled in, caught up or trapped as well as due to abrasion, grazing and cutting.

All components and connections must be checked before switching on the pneumatic system.

- Make sure that the SBU Advanced is switched off.
- Make sure that the removal of the SBU Advanced has been approved.
- Inform yourself about the safety regulations at the dismantling location. If you need to carry out welding or grinding work you must first obtain a welding and grinding permit – a so-called welding permit – from the operating company.
- Use the personal protective equipment (PPE) prescribed for the work during the dismantling of the SBU Advanced.

Operating instructions - SBU Advanced

- Move the butterfly of the valve to the CLOSED position so that the valve is fully closed.
 - Make sure that the pneumatic actuator is depressurised.
 - Secure the SBU Advanced appropriately against slipping, tipping over or falling down.
-

DANGER

Danger due to incorrect attachment.



Very serious damage to the SBU Advanced.

Do not suspend the SBU Advanced on attachment devices as there are no attachment points for this.

Ensure safe manual transport of the SBU Advanced.

Ensure that the SBU Advanced is safely packed.

- Unscrew and remove the cover, release all the electrical cables and pull them out of the housing.
- Undo the four interior hex socket-head screws and pull the SBU Advanced off the quarter turn actuator.
- Remove the four loosened screws from the interior.
- Screw the cover back onto the lower part and secure the SBU Advanced in a suitable transport box.

F) Test run after installation

F01 Test run

The SBU Advanced delivered has been manufactured, factory-preset and tested for the technical data specified in the order.

Nevertheless you must ensure the perfect function after full installation of the SBU Advanced. Therefore, be sure to carry out and document the following steps before commissioning.

- Check that all components and connections have been mounted correctly and firmly.
- Check the proper mounting of the SBU Advanced on the pneumatic quarter turn actuator.

DANGER

Danger due to incorrect adjustment or indication.



Serious damage to the SBU Advanced during operation.

A false indication or feedback represents a hazard.

Make sure that the OPEN and CLOSED positions of the valves correspond to the controller.

INFO

Note.



Observe the adjustment and indication of the valve and actuator.

The setting of the CLOSED end stop of a new SBU Advanced should not be changed as long as the quarter turn actuator is in the CLOSED position.

Refer to the information in these operating instructions for readjustment.

DANGER

Danger to life due to high voltage.



Very serious injuries or death due to electrocution.

People could come into contact with live parts

The SBU Advanced may only be connected by an electrician.

Carry out the test run only with the switch box closed.

DANGER

Danger due to uncontrolled start-up of the pneumatic quarter turn actuator.



Very serious injuries due to incorrectly connected pneumatic quarter turn actuator or uncontrolled start-up.

Very serious injuries due to being crushed, pulled in, caught up or trapped as well as due to abrasion, grazing and cutting.



All components and connections must be checked before switching on the pneumatic system.

- Check the earthing of the SBU Advanced.
- Switch the SBU Advanced on and carry out a test run. Make sure that when control pressure is applied, the respective valve or quarter turn actuator is driven to the intended end position with the corresponding control commands "CLOSED" and "OPEN".

G) Product description

G01 Use for the intended purpose

The SBU Advanced is intended to be used in conjunction with pneumatic quarter turn actuators for valves. It serves to detect the signals for the state "Open"/"Closed" or position 0° and 90°.

The SBU Advanced is a microcontroller-assisted switch box. It has four interfaces. These are:

- Connection terminals for the feedback signal OPEN/CLOSED & collective error (exceeding the set operating parameters)
- Connection terminals for wiring a solenoid valve coil
- Optional Connection terminals for wiring external sensors (e.g. for the use of linear actuators)
- Bluetooth 4.0 interface for the visualisation of the operating states or the setting of the operating parameters using the free EBRO Connect app (available in the Apple App Store and Play Store).

The mechanical adaptation to the pneumatic actuator is done directly at the connection point for positioners and signal devices according to VDI/VDE 3845 AA2 80 mm x 30 mm and 30 mm shaft height (max. dia. 30 mm). Mounting kits according to VDI/VDE 3845 with different bracket dimensions are available for other attachments.

The SBU Advanced is used only in an area that is not potentially explosive.

The SBU Advanced may only be put into operation after the following documents have been read:

- <Explanation of the EU directives>
- These assembly/operating instructions

Failure to observe this <intended purpose of use> represents gross negligence and relieves the manufacturer EBRO-Armaturen of its product liability.

DANGER



Danger due to use of the SBU Advanced other than for the intended purpose

People can be seriously injured or killed if the SBU Advanced is used improperly or for a purpose other than that intended. Also, the SBU Advanced may sustain damage.

Use the SBU Advanced only for its intended purpose!

Do not modify the SBU Advanced!

INFO



Be sure to observe all the information in these operating instructions, in particular the safety information. It must be read and observed before all activities on the SBU Advanced.

Any use, adjustment and variation other than that described in these operating instructions is considered to be improper and contrary to the intended purpose of the SBU Advanced!

G02 *Scope of delivery*

The SBU Advanced was conceived and assembled at EBRO ARMATUREN Gebr. Bröer GmbH and is suitable for detecting the signals of the CLOSED / OPEN state of a pneumatic quarter turn actuator. In the form supplied by us as an incomplete machine, the SBU Advanced is intended to be mounted on a pneumatic quarter turn actuator.

The scope of delivery generally includes this device and the associated original assembly and operating instructions.

Immediately upon receipt of the SBU Advanced, check that it corresponds to your order and is complete.

Complain immediately:

- to the delivery company if there is visible transport damage.
- to EBRO ARMATUREN GmbH if there are visible defects or if anything is missing.

H) Service and maintenance

H01 *Service and maintenance in general*

Before commencing with any service and maintenance work, read the entire chapter *Safety information*. When procuring spare and wearing parts, original parts from EBRO ARMATUREN Gebr. Bröer GmbH and from the manufacturers of bought-in parts are to be used. Please note that spare parts not supplied by the respective manufacturer have not been tested and approved. The installation and/or use of such parts may therefore negatively change structurally-related properties of the SBU Advanced and thus impair its active or passive operational safety.

The manufacturer accepts no liability whatsoever for damage caused by the use of non-original parts and accessories.

The necessary work and activities on the SBU Advanced may only be carried out by qualified personnel; refer also to the chapter *Qualified personnel*.

The safety information given must be observed without fail and applies to all sub-chapters.

The maintenance must be approved by the operating company and may only be carried out by qualified personnel.

CAUTION

Damage to and malfunctions of the SBU Advanced due to a lack of maintenance.



Material damage to the SBU Advanced and possibly shorter service life.

Service and maintain the SBU Advanced at the specified intervals!

Observe shift operation!

DANGER

Danger to life due to high voltage.



Very serious injuries or death due to electrocution.

The SBU Advanced may only be connected by an electrician.

Switch the SBU Advanced off and secure it against being switched on again.

DANGER

Danger due to uncontrolled start-up of the pneumatic quarter turn actuator.



Very serious injuries due to incorrectly connected pneumatic quarter turn actuator or uncontrolled start-up.

Very serious injuries due to being crushed, pulled in, caught up or trapped as well as due to abrasion, grazing and cutting.



Make sure that the pneumatic quarter turn actuator is depressurised before commencing with maintenance.

All components and connections must be checked before switching on the pneumatic system.

NOTE



Switch the SBU Advanced off and secure it against being switched on again with a lock!

Switch the electrical components and the SBU Advanced off and secure them against being switched on again for all work, before service, during adjustment and maintenance.

See chapter A11 on maintenance!

H02 Maintenance intervals

The service life is limited to 10 years or 1,000,000 switching cycles at the most.

This documentation must be available in case of maintenance or repair work by the manufacturer.

Element	Maintenance activity	Maintenance intervals			Information
		Before each shift	Daily	Every six months	
Complete SBU Advanced	Inspection	•	•		Report changes in the operating behaviour immediately and have them rectified!
Check cable glands for firm seating	Inspection			•	Check cable glands every 6 months for damage or improper use.
Check cable connection for firm seating	Inspection			•	Check the terminal connections of the cables every 6 months.
Complete SBU Advanced	Cleaning			•	All dirt must be cleaned off at least every 6 months!

H03 Cleaning of the SBU Advanced in general

Depending on the environment, the SBU Advanced may occasionally be exposed to a mixture of oil, dust and other foreign particles. The operation and function of the SBU Advanced can be negatively affected by these deposits.

In order to avoid these malfunctions you must adhere to the maintenance intervals and clean the SBU Advanced from the outside at least every 6 months.

DANGER

Danger due to components moving in an uncontrolled manner.



Very serious injuries due to being crushed, pulled in, caught up or trapped as well as due to abrasion, grazing and cutting.

The SBU Advanced must be switched off and secured against being inadvertently switched on again before any cleaning work.

Do not carry out cleaning during running operation.

CAUTION

Danger due to incorrect or aggressive cleaning agent.



Injuries or damage to the SBU Advanced.

The safety data sheets for the cleaning agent must be available and observed.

Use only a dry cloth and if necessary a commercially available cleaning agent.

DANGER

Danger to life due to high voltage



Very serious injuries or death due to electrocution.

Fluid can penetrate into the switch box if spray water with too high a pressure is used. People could come into contact with live parts.

Switch the SBU Advanced off and secure it against being switched on again.

The SBU Advanced may only be connected by an electrician.

Dust layers on the components of the SBU Advanced could impair the exchange of heat with the ambient air. This can lead to a build-up of heat. In order to avoid an impermissible temperature increase above the maximum permissible surface temperature, any deposits or dust layers must be removed.

Dust layers are to be removed by vacuum cleaning before the layer thickness reaches 5 mm.

I) Errors, causes and remedial action

I01 Errors in general

Before commencing with troubleshooting, read the chapter *Safety information*. The safety information given must be observed without fail and applies to all sub-chapters.

DANGER

Danger to life due to high voltage.



Very serious injuries or death due to electrocution.

The SBU Advanced may only be connected by an electrician.

Switch the SBU Advanced Pro off and secure it against being switched on again.

DANGER

Danger due to uncontrolled start-up of the pneumatic components.



Very serious injuries due to incorrectly connected pneumatic components or pneumatic components that start up in an uncontrolled manner.

Very serious injuries due to being crushed, pulled in, caught up or trapped as well as due to abrasion, grazing and cutting.



Make sure that the pneumatic quarter turn actuator is depressurised before commencing with maintenance.

All components and connections must be checked before switching on the pneumatic system.

NOTE



Switch the SBU Advanced off and secure it against being switched on again for all work, before service, adjustment and maintenance.

Depressurise the pneumatic quarter turn actuator and secure it against being pressurised.

102 Collective error

Errors are signalled by the flashing of the red Error LED and the switching of the Collective Error output X1.6.

No error messages have any effect on the current program sequence.

The error is reset once the cause of the error has been rectified.

103 Errors – Cause – Remedial action

Errors that can be signalled by the SBU Advanced are:

Error	Cause	Remedial action
Collective error	Runtime monitoring: The set running time is exceeded. Default value: 0 s (deactivated)	Check the following components: - Valve switched - Actuator function Check compressed air supply Check the position of the cam plate. Check for jamming in the pipeline. The fault is automatically reset as soon as the repeated ride is within the time tolerance.
	Max. switching cycles: Max. set switching cycles reached. Default value: 0 n (deactivated)	Check the number of switching cycles performed. Reset or increase the counter.

All error messages are deactivated with the setting value "0".

J) Disposal

J01 Environmental protection

Contribute to the protection of the environment by recycling valuable raw materials and thus preserving resources.

In all other cases we refer you to the disposal regulations of the respective countries.

What is to be disposed of?	Material	How is it to be disposed of?
Transport material	Pallets	Back to the manufacturer or freight forwarder
Packaging	Paper and cardboard boxes	Put in the paper recycling
	Plastics	Put in the plastic recycling
Cleaning cloths Oil and grease	Fabric, oils and greases	Oily and greasy waste
Components	Controller	Put in the electronic scrap
	Electronic devices and components	Put in the electronic scrap
	Metal	Metal recycling
	Plastics	Put in the plastic recycling

CAUTION

Danger due to operating resources or hazardous materials.



Serious personal injuries or serious damage to the environment.

The safety data sheets for the operating resources and hazardous materials must be available and observed.

Use the personal protective equipment stipulated in the safety data sheet when handling the respective hazardous material.

For all work on and with the SBU Advanced, comply with the legal obligations for avoiding waste and for proper recycling and disposal in accordance with the safety data sheet!

In particular in the case of installation repair and maintenance work, water pollutants such as lubricating greases and oils must not contaminate the floor or get into the sewer! These materials must be stored, transported, caught and disposed of in suitable containers!

K) Spare parts

K01 Spare parts in general

When procuring spare and wearing parts, original parts from EBRO ARMATUREN Gebr. Bröer GmbH and from the manufacturers of bought-in parts are to be used. Please note that spare parts not supplied by the respective manufacturer have not been tested and approved. The installation and/or use of such parts may therefore negatively change structurally-related properties of the SBU Advanced and thus impair its active or passive operational safety.

The manufacturer accepts no liability whatsoever for damage caused by the use of non-original parts and accessories.

The list of spare and wearing parts can be found in the appendix to these operating instructions.

K02 Ordering spare parts

The following details must be supplied with each spare part order:

- Type.
- Article number.
- Order number.
- ID no. or drawing no. (parts catalogue).

If these four points are disregarded we cannot guarantee prompt handling of the spare parts order.

L) EBRO Connect

This chapter describes the user interface of the EBRO Connect App in more detail.

Start screen

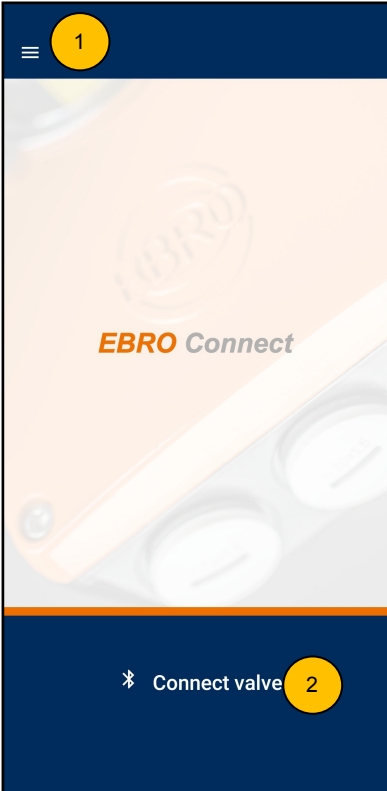

- 1 Menu selection
- 2 request button overview page
- 3 Enter password initial password: 0000

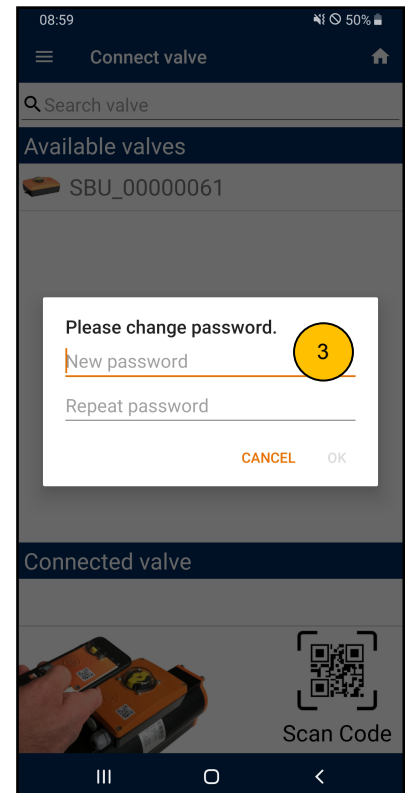
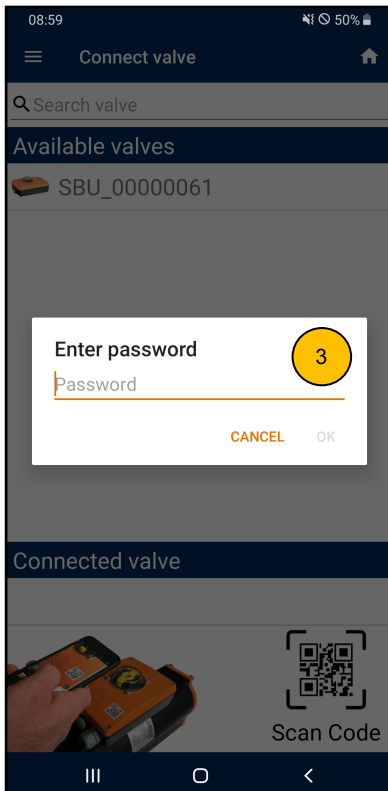
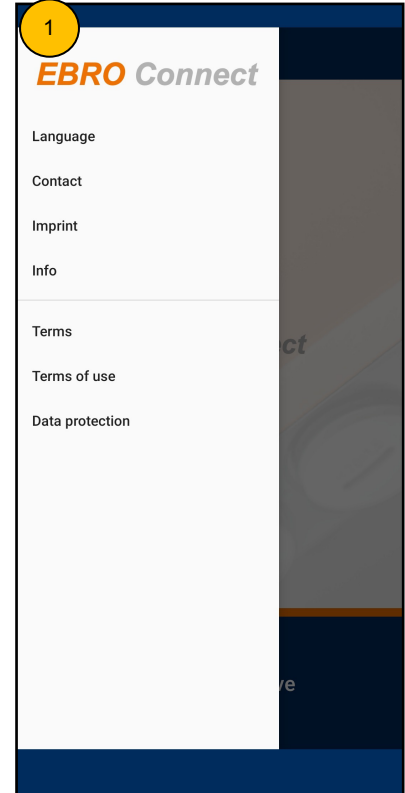

Overview page

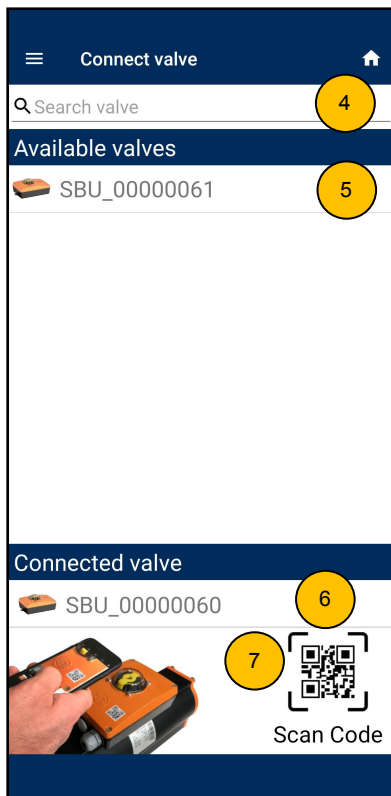

- 4 Search box
- 5 Units available within range
- 6 Currently connected unit
- 7 Button for a possible QR-code scan

- 8 Quick Buttons - BT disconnect, Share menu, Home button
- 9 Digital nameplate of the SBU Advanced
- 10 Current status and device information
- 11 Select categories

Category Status

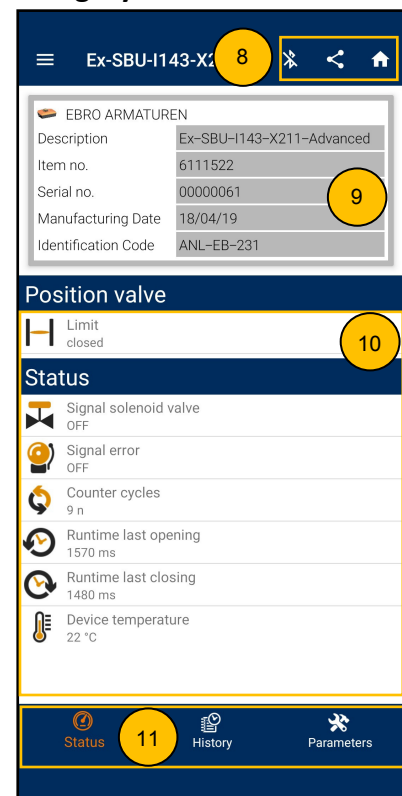

Category History

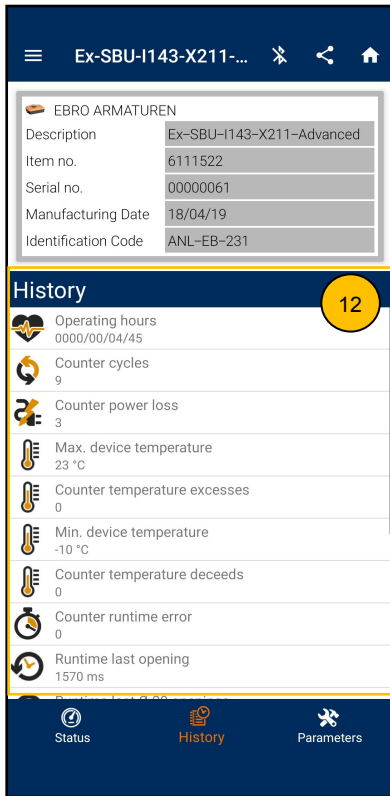

12 Additional device information and events

13 Parameter settings

Category Parameter

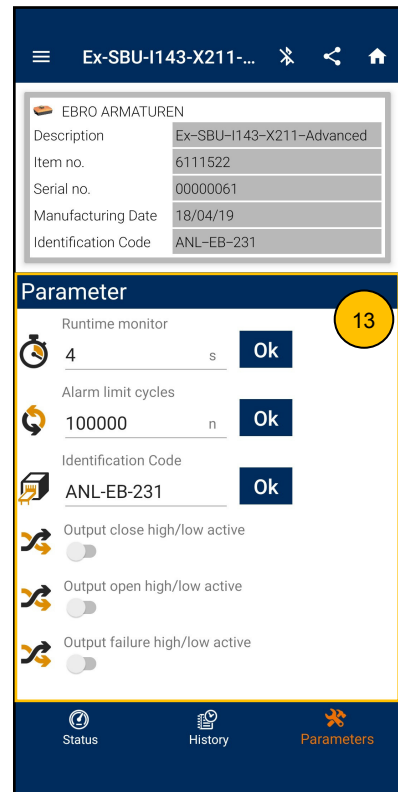

EC Declaration of conformity

Declaration in accordance with EC Directives

KE_SBUADV00

Rev00/2018-10/AF

The manufacturer

EBRO Armaturen

Gebr. Bröer GmbH
Karlstrasse 8
58135 Hagen
Deutschland



Declares that the switchbox unit
series SBU-Advanced-XXXX

are manufactured in accordance with the requirements of the following standards:

EN 301 489-1 V2.1.1 (2017-02)
EN 55032 +C1 (2015/2016)
EN 61000-4-2 (2009)
EN 61000-4-3 +A1+A2 (2006/2008/2010)
EN 61000-4-4 (2012)
EN 61000-4-6 (2009)
ETSI EN 300 328 V2.1.1
IEC 60950-1:2005 (2nd Ed.) + Am1:2009 + Am2:2013
EN 60950-1:2006 + A11:2009 + A1:2010 + A12:2011 + A2:2013

The following product documents are available:

Planning documents, technical data sheets, catalogue pages

These products conform to the following directives:

Radio Equipment Directive 2014/53/EU (RED)
Electromagnetic compatibility 2014/30/EU (EMC)
Machinery Directive 2006/42/EC

1. The products are an "incomplete machine" in the sense of article 2 g) of this directive
2. The table overleaf lists whether and how the requirements of this directive are fulfilled
3. This declaration is the mounting declaration in the sense of this directive

For conformity with the above- named directives, the following apply:

1. The user must comply with the <correct use> as defined in the "Original mounting and operating instructions" (BA SBU-Advanced) included in the delivery and must follow all notices in these instructions.
Failure to comply with these instructions can – in serious cases – release the manufacturer from product liability.
2. Commissioning of the Limit Switches Box is not permitted until conformity of the system in which the Limit Switches Box is installed with all the above- mentioned EU directives is declared by the person responsible. A specific declaration is included in delivery for the above - named actuator.

Hagen, October 2018

sgd. Lydia Bröer
CEO

EBRO Armaturen, Gebr. Bröer GmbH
Karlstrasse 8
D-58135 Hagen

