

Digital Positioner EP200

The microprocessor-controlled Positioner EP200 is used for analog (4 ... 20 mA) control and feedback of pneumatic actuators. It offers extended functionality of advanced positioner, such as Autostart for the determination of the best control parameters, and comfortable in-the-field operation.

Additional equipment:

- Integrated inductive limit switches, independent of device electronics



- Easy local operation with three key pads
- Multi-Lingual full text graphical LCD
- Load 300 Ω
- Low air consumption
- Stroke 8 to 120 mm (optional up to 260 mm)
- Angle range up to 95 degree
- Supply air pressure up to 6 bar (90 psig)
- Single acting or double acting
- Position Feedback 4-20 mA and Alarm, galvanically separated
- Mechanical travel indicator
- Reverse polarity protection and Interlock diode
- Autostart with self-calibration
- Attachment to rotary actuators according to VDI/VDE 3845
- Protection class IP 65 and NEMA 4X

Accessories:

- Gauge attachment for supply air and outputs
- Booster relays

Repair and maintenance operations must be carried out by qualified personnel!

TABLE OF CONTENTS

CHAP: CONTENT	PAGE	CHAP: CONTENT	PAGE
1	METHOD OF OPERATION	3	
1.1	General	3	
1.2	Block diagram	3	
1.3	Operation.	3	
1.4	Operating Modes	4	
2	LABELS	5	
3	DESIGN.	6	
3.1	Accessories	7	
4	MOUNTING TO ROTARY ACTUATORS.	8	
5	SYSTEM CONFIGURATION	10	
5.1	Application	10	
5.2	Split Range	10	
6	ELECTRICAL CONNECTION	11	
8	START-UP	12	
8.1	Setting by means of local keys	12	
8.2	Operation.	12	
8.3	Configuration	13	
8.4	Description of menus	18	
9	DECOMMISSIONING	31	
10	SAFETY REQUIREMENTS.	32	
11	TROUBLE-SHOOTING GUIDE	33	
12	MAINTENANCE	38	
13	OPTIONS	39	
13.1	Limit switch	39	
13.2	Additional Inputs / Outputs	40	
14	DIMENSIONS	41	
	ORDER CODES	42	

1 METHOD OF OPERATION

1.1 General

The intelligent positioner EP200 **1** and the pneumatic actuator **2** form a control loop with the setpoint value w (from master controller or control system), the output pressure y and the position x of the actuator on valve **3**.

The positioner can be attached to both linear and rotary actuators.

Actuators with spring force are controlled by a single acting positioner. Actuators without spring force are controlled by a double acting positioner.

For the supply air, we recommend the FOXBORO ECKARDT FRS923 filter regulator.

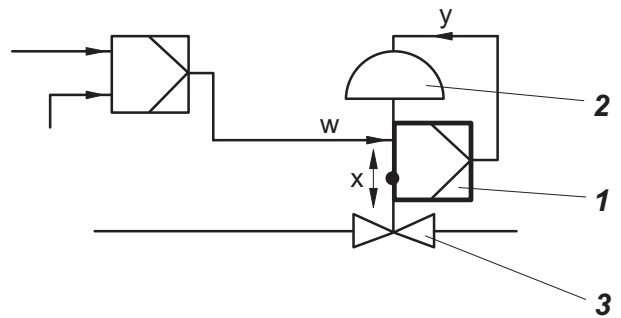

1.2 Block diagram

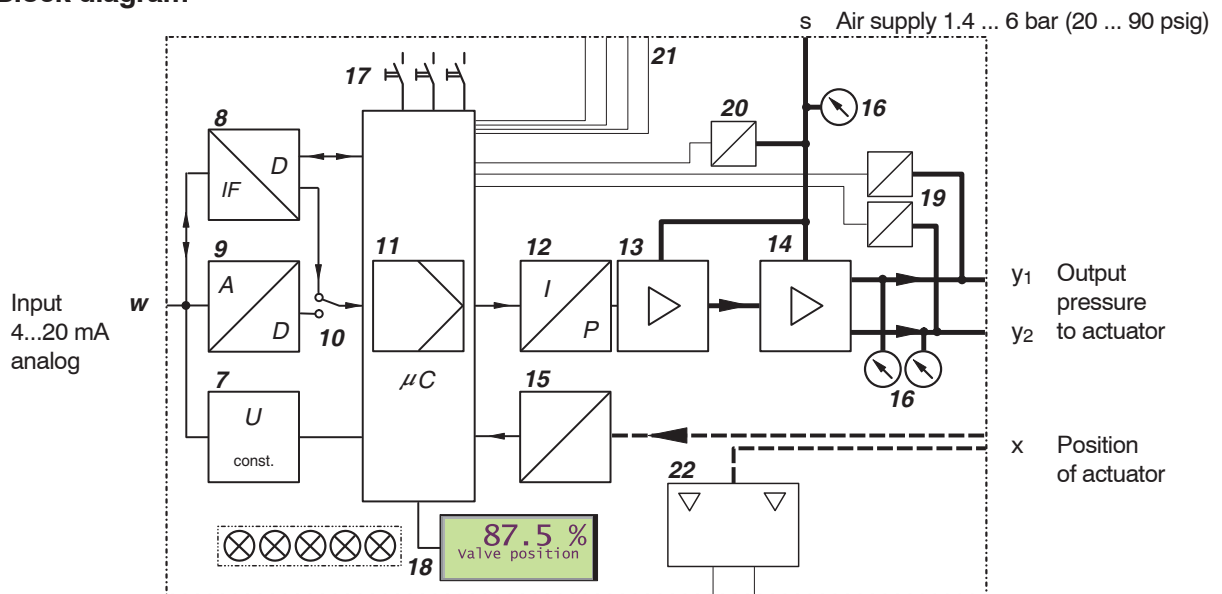

1.3 Operation

With the intelligent positioner with input signal 4-20 mA, the supply takes place via the power signal adjacent to the input.

By means of voltage converter **7**, derivation of the internal supply of the electronics takes place. The power value is measured, in A/D transformer **9** converted, and directed via switch **10** to digital controller **11**.

The output of controller **11** drives the electro-pneumatic converter (IP-module) **12**, controlling a pre-amplifier **13**, the single acting (or double acting) pneumatic power amplifier **14**. The output of the amplifier **14** is the output pressure y to the actuator.

The pneumatic amplifiers are supplied with supply air s 1.4 to 6 bar (20 to 90 psig).

The position x of the actuator is sent to the control unit **11** by the position sensor (conductive plastic potentiometer) **15**.

Optional inputs / outputs **21** (two binary outputs; a 4-20 mA output and alarm; control inputs for 'Open/Close' and 'Hold last value') enable additional diagnostic indications and possible intervention.

The mechanical limit switch **22** (optional) enables independent alarm signals.

Adjusting, start-up of the positioner as well as the demand for internal information can be made using the local keys **17** with indication given by LCD **18**.

1.4 Operating Modes

Operation of the positioner is divided into individual 'operating modes'. Operating modes may change depending on, for example, key commands or internal calculations. The different operating modes are described in abbreviated form below. See also page 36, Phase Diagram.

INITIALIZE:

Upon power-up or Reset (pressing of the 3 keys simultaneously), several self-tests are conducted. Individual steps in the self-test process are indicated by the LCD.

If no error occurs the device moves to OUT OF SERVICE, if it is still in a delivery condition; AUTOSTART has to be performed. If AUTOSTART was done already, the device will go to IN OPERATION.

If faults are detected, the code of the faulty self-test will remain (see page 33). If error reoccurs after reset, the device is probably defective and should be sent in for repair.

DEVICE FAULT:

Device faults are detected during cyclical self-test. The device can no longer be operated.

This could be caused by a jammed menu key, defective program memory, etc. (see chapter "Trouble-shooting"). By reset this state disappears until the same error is detected again.

If a device error occurs repeatedly, the device should be sent in for repair.

IN OPERATION:

After performing an AUTOSTART, the device moves to IN OPERATION.

It will always, even after restarting or resetting, move back to IN OPERATION.



OUT OF SERVICE:

The EP200 in delivered condition is configured in such a way that it will remain OUT OF SERVICE after power-up until moving to IN OPERATION via the manually initiated function AUTOSTART.

In the device state OUT OF SERVICE, the menu entering mode remains active at all times. If a device has been IN OPERATION already and is removed from an actuator and mounted to another, it is recommended to take the device out of operation via RESET CONFIG (Menu 9.1) prior to disconnecting the device from the first actuator.

This enables the next actuator to be started in the delivered condition (see chapter 8).

CALIBRATE:

During an AUTOSTART function the device is in condition CALIBRATION. The actuator is moved up- and downward several times, and the device could be busy for a few minutes. Subsequently, the device moves to IN OPERATION.

MESSAGE:

The EP200 continuously supervises important device functions. In the event that limit values are exceeded or operational problems occur, messages are signaled via the LCD.

The message with the highest priority will be indicated first. With key DOWN additional messages can be called up, with key UP the measuring values can be retrieved. It is possible at all times to reach the menu by pressing the menu keys to possibly eliminate the problem by performing suitable menu functions. Further references may be found in chapter "Trouble-shooting".

Possible operator interventions are described in chapter: START-UP.

Definitions

- Angle range** is the rotary range of rotary actuator.
- 0 % position** is the mechanical impact at actually closed valve (caution if using handwheel and mechanically adjustable stroke limitation!)
- 100 % position** is the mechanical impact at actually open valve.
- Closing limit** is a lower limit set via software. In normal operation the valve will not close more than set here.
Attention: In the event of failure of the auxiliary energy no controlling is possible, therefore the springs in the actuator will move the valve into safety position (for single-acting actuator).
- Opening limit** is a upper limit set via software. In normal operation the valve will not close more than set here.
Attention: In the event of failure of the auxiliary energy no controlling is possible, therefore the springs in the actuator will move the valve into safety position (for single-acting actuator).
- Normal operation** (= IN SERVICE) means that the position is controlled to the 4-20 mA input signal.

2 LABELS

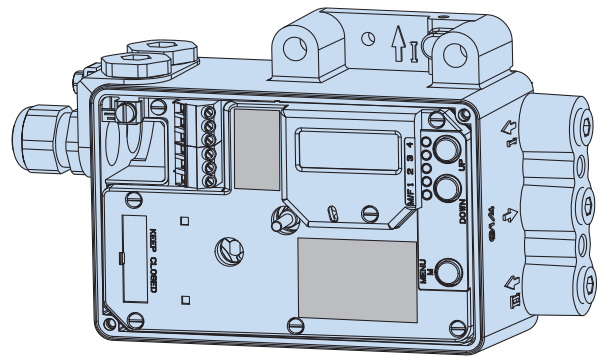
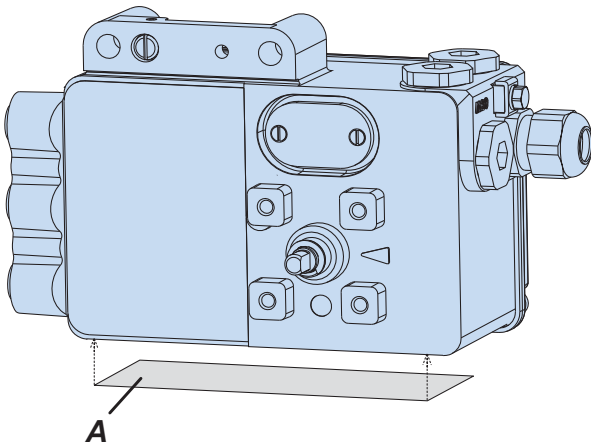

A Nameplate

Nameplate (Example)

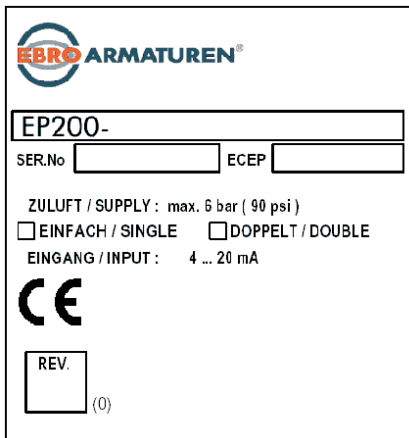

- EP200 equipment specification, Model Code
- SER.No serial number
- ECEP number for special equipment

3 DESIGN

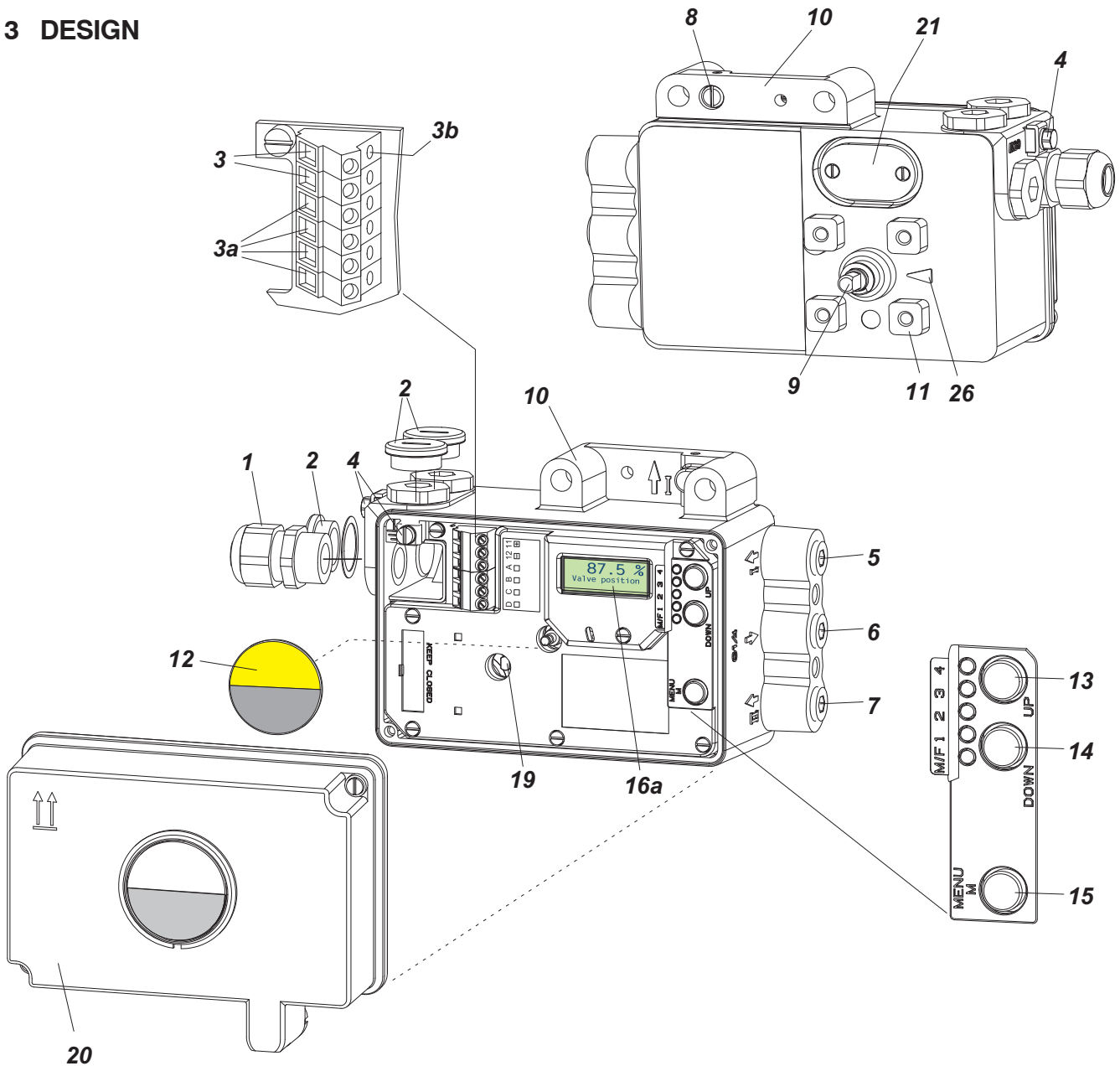

- 1 Cable gland M 20x1,5
- 2 Plug, interchangeable with Pos. 1
- 3 Screw terminals (11 / 12) for input (w)
- 3a Screw terminals for options
- 3b Test sockets Ø 2 mm, integrated in terminal block
- 4 Ground connection
- 5 Female thread G 1/4 for output I (y1)
- 6 Female thread G 1/4 for air supply (s)
- 7 Female thread G 1/4 for output II (y2)
- 8 Direct attachment hole for output I (y1)
- 9 Feedback shaft

- 10 Connection manifold for attachment to stroke actuators
- 11 Connection base for attachment to rotary actuators
- 12 Travel indicator
- 13 Key **UP**
- 14 Key **DOWN**
- 15 Key **M** (Menu)
- 16a LCD with true text in 3 different languages
- 19 Fixing shaft for limit switch
- 20 Cover with window to 12
- 21 Air vent, dust and water protected
- 26 Arrow is perpendicular to shaft 9 at angle 0 degree

3.1 Accessories

When mounting, check the proper seating of the O-rings and bolt on the accessories with the two M8 bolts. Unused outputs are closed by means of plastic plugs.

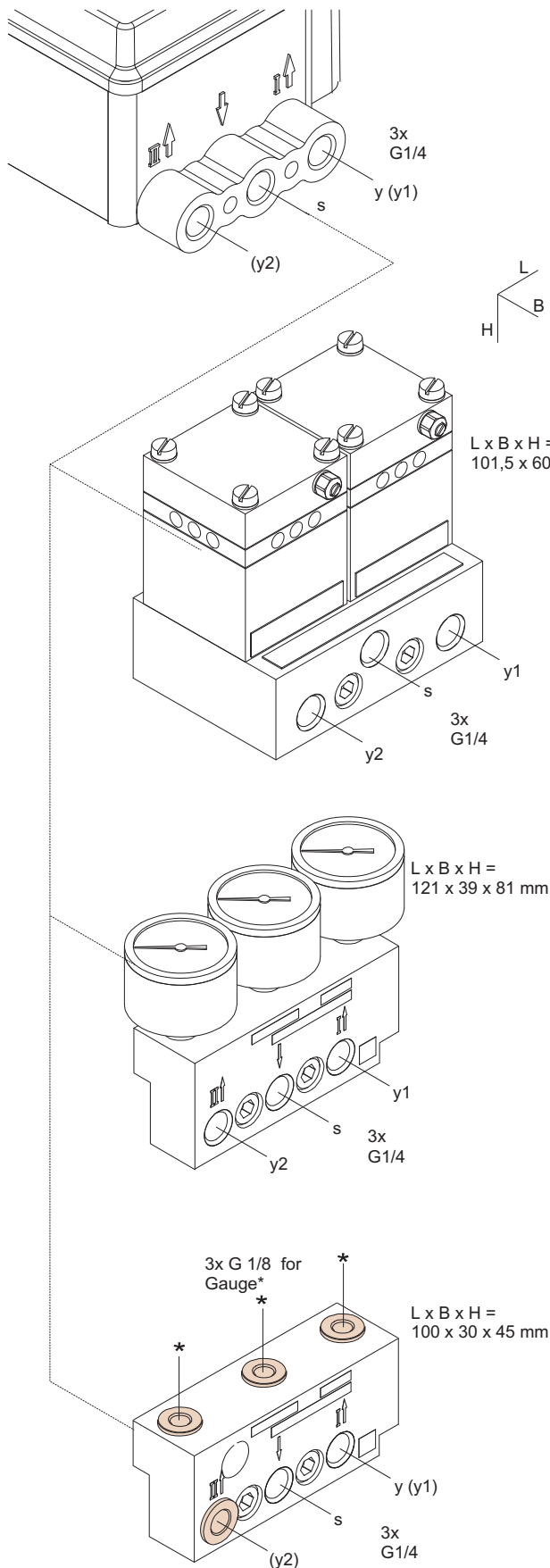

L x B x H =
101,5 x 60 x 100,5 mm

Code LEXG -G1
Booster for positioner

L x B x H =
121 x 39 x 81 mm

Code LEXG -M1
Connection manifold for positioner
with pressure gauges for
supply air s, outputs y1 and y2

L x B x H =
100 x 30 x 45 mm

Code LEXG -N1
Connection manifold positioner
with threads G 1/8 for pressure gauges
for supply air s, outputs y(y1) and (y2)
(supplied without pressure gauges)

* Unused threads for pressure gauges are closed by means of plastic lock screws.

4 MOUNTING TO ROTARY ACTUATORS

Applicable to rotary actuators that meet the VDI/VDE 3845 standard for mounting. Installation position of positioner: Mount the positioner so that the pneumatic connections are in the same direction as the longitudinal drive axis of the actuator as shown below.

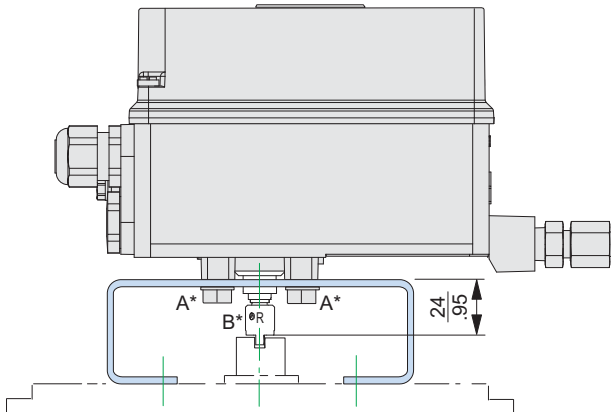

Attention: The feedback shaft **9** of the EP200 has no mechanical stop, therefore may spin 360 degrees. The permissible rotation angle range is between +50 and -50 degrees around the arrow at the housing concerning the flat area of the feedback shaft (also see detail page 9 bottom). Since a rotary actuator has a rotary angle of about 90 degrees the mounting as described in the following must be carried out very precisely.

Attachment of the positioner to the actuator is made by using the rotary adaptor kit EBZG -R.

The side outputs I (or I and II) are used. The rear output I is closed by means of a lock screw.

Pneumatic connections: Do not use Teflon tape for sealant. The fine fibres could disturb the function of the EP200. Use only Loctite® #243 for sealant ¹⁾.

Screw-type glands for electrical connections are used as needed. Any unused threaded holes are closed by plugs.

Caution! Prevent accumulation of water in the instrument in this mounting position by sealing cable entry against water. Provide a continuous supply of dry instrument air.

1) Apply only to male thread.

2) Failsafe position: Actuator moves in this defined position when the electrical supply fails

4.1 Preparation of positioner

Valve must be in failsafe position²⁾ and the direction of rotation of the actuator drive shaft must be known. These items are extremely important for proper functioning. These items can be checked as follows in case they are not clear:

- In the single-acting actuator the force of the installed spring closes. The pressure-less actuator is in failsafe position. Through manually feeding compressed air it can be seen whether the actuator drive shaft rotates to the left or to the right. Without electrical power, $y_1=zero$.
- In the double-acting actuator (without spring reset) both air chambers are basically equal. Failsafe position can be either "open" or "close". Therefore, indication of the failsafe position has to be determined by engineering. Then the direction of rotation may be determined by manual feeding of compressed air. Without electrical power, $y_1=zero$ and $y_2=supply$.

Threaded pin **2** is screwed into actuator drive shaft **1** for subsequent centering of the rotary adaptor **3**. The attachment console is mounted to the rotary actuator (see illustration left).

Attachment diagram for bracket (view from below)

Reference points A* see illustration left

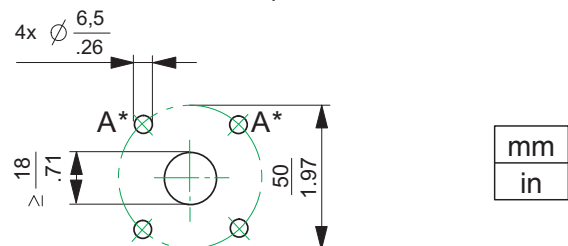

Coupling piece

Reference points B* see illustration left

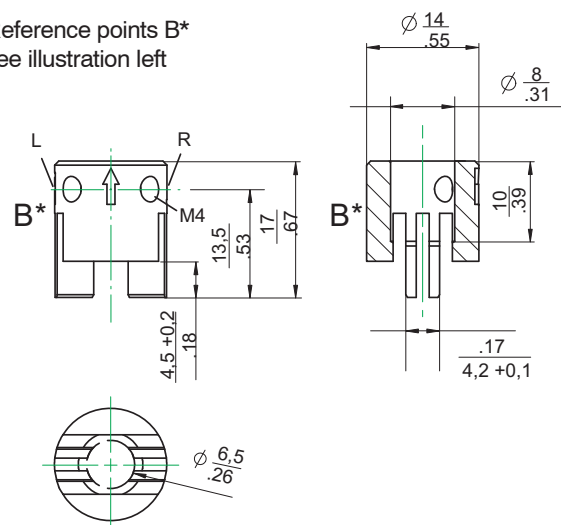

4.2 Preparation of the actuator

The feedback shaft **9** of the EP200 has no mechanical stop, therefore may spin 360 degrees. The permissible rotation angle range is between +50 and -50 degrees around the arrow at the housing concerning the flat area of the feedback shaft (also see detail below).

First turn the feedback shaft **9** with the flat area to the 50 % position marked with the arrow **10**.

- For attachment to a counter-clockwise or *left* turning actuator turn the feedback shaft 45° counter-clockwise to the 0 % position. See Fig. L.
- For attachment to a clockwise or *right* turning actuator turn the feedback shaft 45° clockwise to the 0 % position. See Fig. R.

Now do not adjust the feedback shaft any longer!

Then screw the threaded pin **4** into a threaded hole of the coupling piece **3**, so that the threaded pin points to the flat area of the feedback shaft, while the catch of the coupling piece is aligned with the groove in the drive shaft **1**.

Now place the prepared coupling piece with two washers **5** on the feedback shaft **9** of the positioner against the stop. Note:

When the product temperature rises, the drive shaft **1** becomes longer. Therefore, the coupling piece must be mounted so that approx. 1 mm (0.04 in.) of clearance results between the drive shaft and the coupling piece.

This is achieved by placing an appropriate number of washers **5** on the feedback shaft stub **9** before attaching the coupling piece. Two washers should result in a clearance of 1 mm.

Now screw and tighten the threaded pin in the coupling piece against the flat part of the feedback shaft (do not screw against thread!).

Finally turn the feedback shaft in such a way that the arrow of the coupling piece points to the arrow of the EP200 housing.

Beginning and end positions of the actuator drive shaft **1** and feedback shaft **9** are marked in the illustrations below by arrows for the respective direction of rotation.

The feedback shaft is now in the normal position corresponding to the failsafe position of the actuator.

4.3 Mounting of positioner

EP200 and actuator are in failsafe position.

Attach the EP200 on the console in such a way that the catch of coupling piece **3** is guided into the groove of shaft **1**. Use threaded pin **2** to center and align the positioner to the actuator. Be careful not to shift shafts **1** and **9** and that both shafts are exactly flush.

Fasten the positioner to the bracket by means of 4 lock washers and 4 screws M6 x 12.

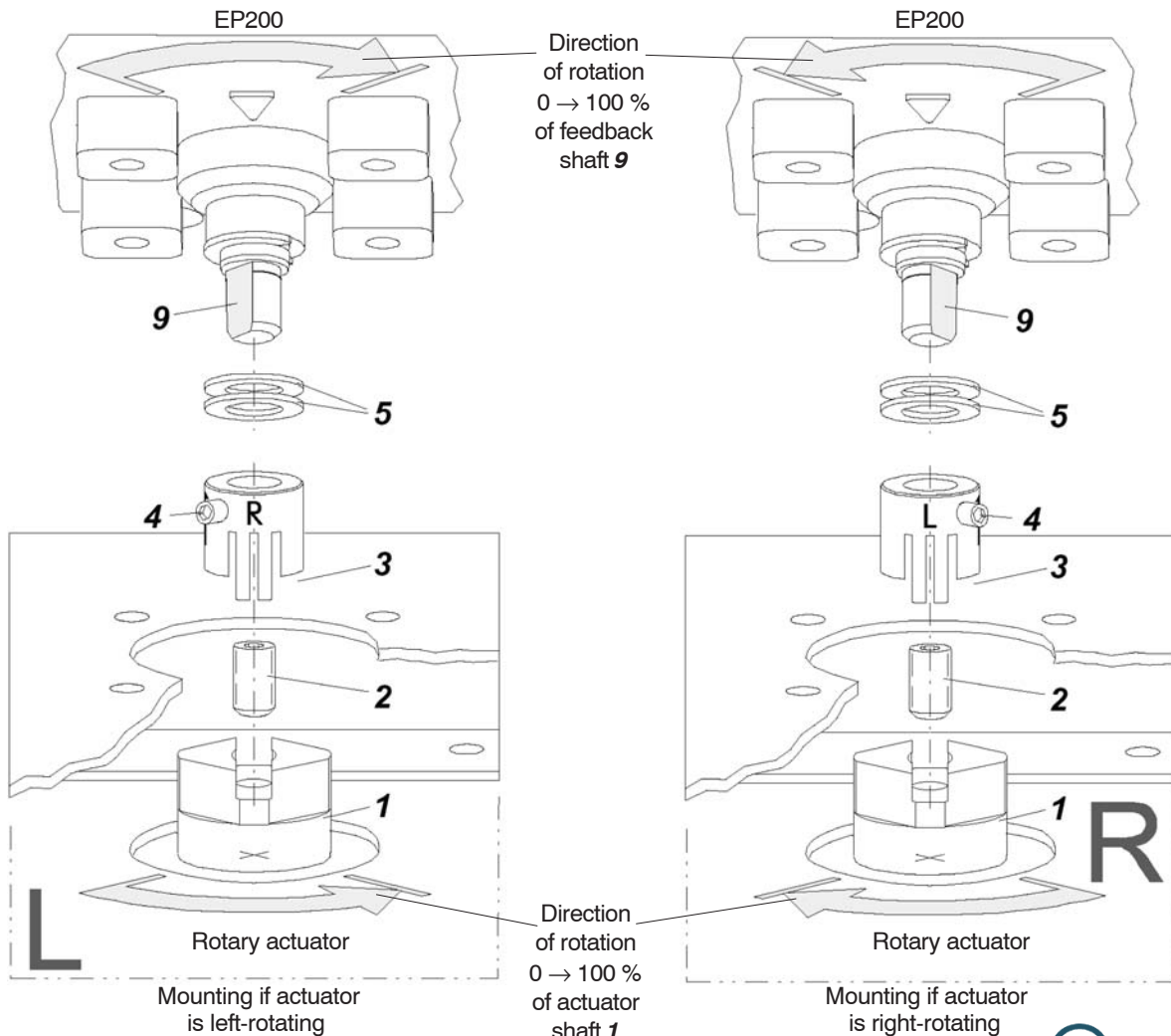

5 SYSTEM CONFIGURATION

The safety requirements must be observed!

5.1 Application

The EP200 can be connected directly to the 4 to 20 mA output of the process control system or controller. Load RL about 320 ohms.

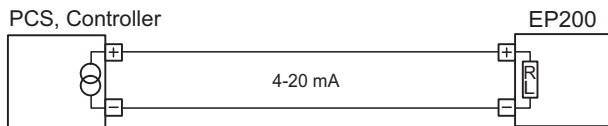

The following devices may be used:

Device	Input Load R2	Drives load RL at output	drives n EP200
TV228	< 100 Ω	700 Ω	2 pcs.
II949	RL+200 Ω	580 Ω	1 pc.
MTL4048	RL+450 Ω	750 Ω	2 pcs.
MTL787S+	RL+260 Ω	1200 Ω	3 pcs.

5.2 Split range

If several actuators are to be controlled from an identical conduct variable and carry out full stroke only in a certain portion of this conduct variable, an individual EP200 is to be provided for each actuator the zero and span of which can be set to the respectively desired partial range of the conduct variable.

The positioners are electrically switched in series. It is important that the permissible load of the process control system or controller is not exceeded (RL of an EP200 approx. 320 Ohm).

The output voltage (idle voltage) must be > 8.5 V per connected positioner. The total line capacitance is not to exceed 1 μF.

Example: 2-fold split range

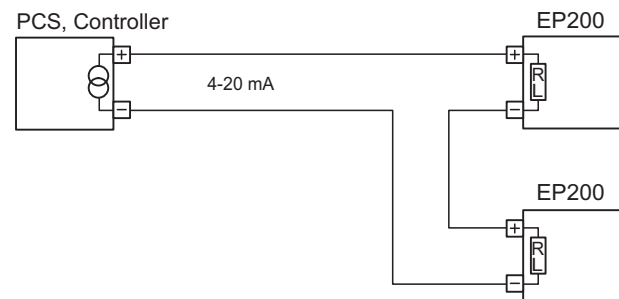

Setting of the positioners is described in page 23.

6 ELECTRICAL CONNECTION

The safety requirements in chapter 10 must be observed!

The cable is guided through gland **1**. Do not insert cable from top; if necessary use opening relocated by 90°. The gland is suitable for cable diameters of 6–12 mm (0.24–0.47 in).

Tightly seal cable entry. Unused cable glands are to be tightly sealed by means of filler plugs.

The input line is connected to screw terminals **3** marked 11+ and 12–.

Terminal	Signal
11+	Input Setpoint value w (4...20 mA)
12–	Input Setpoint value w (4...20 mA)
31+	Analog output 4...20 mA, Pos. feedback
32–	Analog output 4...20 mA, Pos. feedback

Analog output 4...20 mA: ext. supplied

The screw terminals are suited for wire cross- sections of up to 0.3–2.5 mm² (22–14 AWG).

At the side of the screw terminals are integrated test sockets Ø 2 mm (0.08 in).

For enhancement of EMC-protection by connection to a local ground the internal and external ground terminal **4** can be used.

Note: When connecting shielded cable connect the cable shield only to the system! Do not connect the cable shield to the positioner!

There are no jumpers in the device.

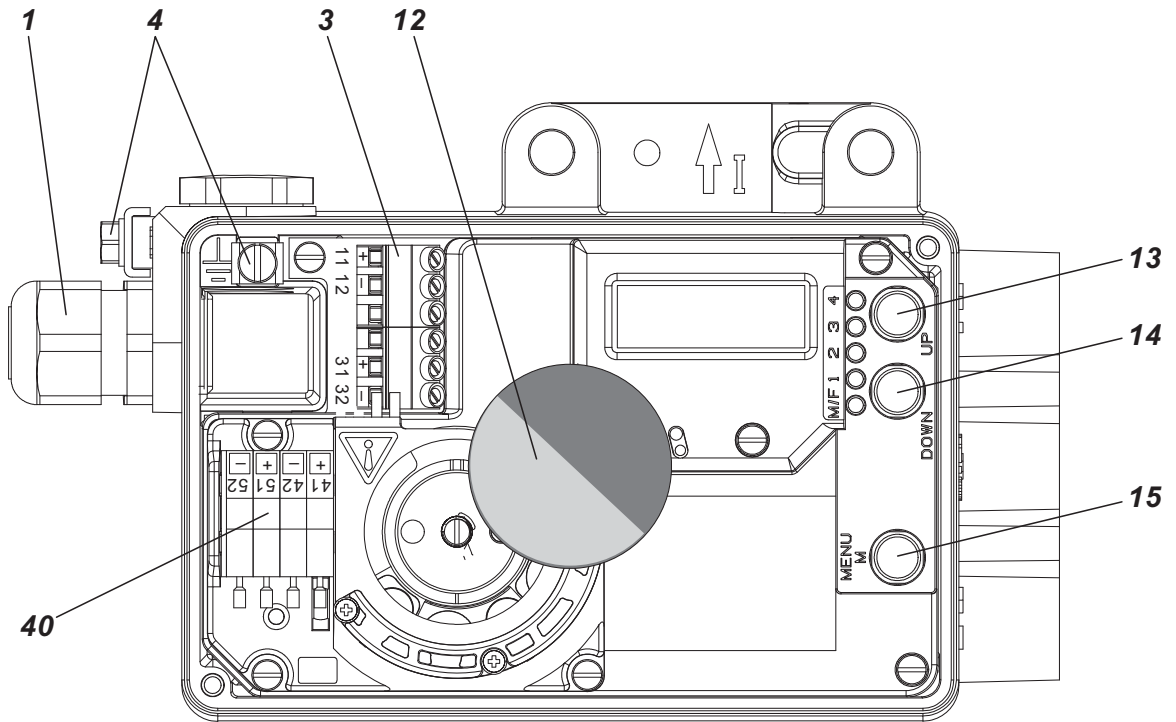

Optional equipment 'limit switch' (Pos. **40**)

EP200-x-T, U, via inductive sensor	
Terminal	Signal
41 +	AG1
42 –	AG1
51 +	AG2
52 –	AG2

AG: Binary output ext. supplied

8 START-UP

General

Before starting the positioner the EP200 has to be mounted to the actuator; power and air supply must be connected. The supply air connection must have sufficient capacity and pressure of 1.4 - 6 bar (20...90 psig) and should not exceed the maximum operating pressure of the actuator.

Attention: Configuration may interfere with operation of the actual process !

The EP200 is generally set by the 3 local keys with housing cover open. During configuration it is recommended that there is no flow through the valve. For **Initial Start-up** it is to configure 'Actuator system, Mounting side' (see menu 1) , then a Autostart or a short Autostart (see menu 2 and 10). After selection of the gear ratio, plug the Travel indicator **12** on the pointer shaft in the desired position. When placing the housing cover, note that the vent opening is directed downward.

8.1 Setting by means of local keys

The setting is made with the three buttons:



- M** (Menu) start menu / end menu
UP / DOWN counting up/down of menu numbers resp. parameter numbers
UP + DOWN simultaneously: confirm at start, or when entering, storing, or verifying
M + UP + DOWN simultaneously: Reset = new start of EP200, thereafter initialization

To view the menu or the device status is the full text LCD display.

The display on the LCD is in plain text:

```
SRD Main Menu
1 Mounting
2 Autostart
3 Valve Action
```

Note: If there is no response using the local key-pad (message 1 appears) make sure that the Write Protection is not set ! Remove the write protection using the special FDT/DTM configuration software.

Warning: When pressing the buttons during configuration, do not touch the rear part of the positioner at any time!
 Risk of injury !

8.2 Operation

After Power ON

INIT: After power on of the input signal, or after reset, the EP200 initializes, and the various components of the electronics are checked and started. (The stored data of the positioner not affected, and remains unchanged). The current status is stated on the LCD in clear text. Initialization after positioner start-up takes approx. 3 sec, then the EP200 goes

- into operation (Autostart has already been done) or
- to configuration, selection of LCD text language (default is English language) ...

```
9.9 Menu Lang
9.9.1 English
9.9.2 Deutsch
9.9.3 (Francais)
```

Select with keys
 UP or DOWN and confirm
 with UP+DOWN (together)

... selection of display orientation ...

```
9.10 LCD Orient
9.10.1 Normal
9.10.2 Flipped
```

... then automatically continued to configuration:

```
SRD Main Menu
1 Mounting
2 Autostart
3 Valve Action
```

8.3 Configuration

MENU: The various specifications for configuration are arranged in menus:

Menu	Description
1	Actuator system, mounting side
2	Autostart, Short Autostart
3	Valve function
4	Characteristic of setpoint
5	Limits and Alarms
6	Parameter for position controller
7	Manual setting of pneumatic output
8	Manual setting of valve position
9	Calibration functions for workshop

In Operation

After accomplished autostart, the EP200 automatically goes IN OPERATION. (Additional parameters can be configured through pressing of menu key M.)

On the LCD display the process variable is indicated.

87.5 % Valve position

Through pressing of keys UP or DOWN, additional information can be retrieved from the EP200:

Valve position
 Travel position
 Input current
 Digital setpoint
 Stem setpoint
 Input pressure
 Output pressure1
 Temperature
 Travel sum
 Valve cycles
 Operation hours
 TAG Number
 TAG Name

Certain data and menus are available only with the corresponding options.

Manual Operation

Through twice pressing of keys UP+DOWN (together), the EP200 goes into manual operation mode, where the valve position can be set manually (see Menu 8). Exit of menu by pressing twice of key M.

Diagnostics during Operation

If the diagnostics determines an occurrence, this is indicated in the bottom line:

87.5 % Valve position Ctrl diff error

MESSAGE: The EP200 recognizes an occurrence which the user must eliminate by taking suitable steps in order to continue with operation. This can be e.g. a wrong configuration or missing supply air.

ERROR: During self-testing the EP200 recognized an error and is no longer operable.

Other menu structure and representation

On the following pages, the further operation of the menu and the presentation with the full-text LCD is treated in detail.

Operation with local keys

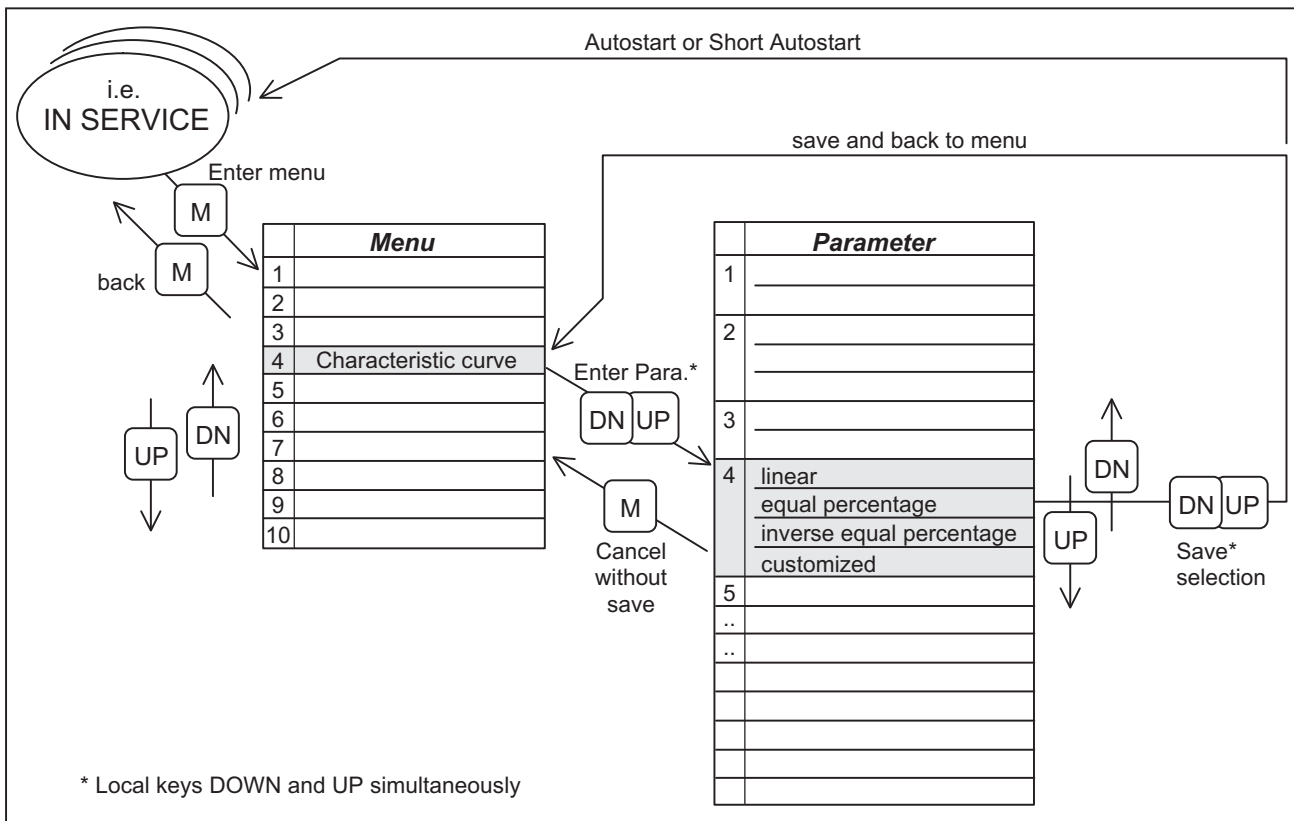

- Enter the **Menu** mode by pressing the M key, and Menu 1 appears.
- Select the desired Menu item by pressing the UP or DOWN key, see table. Each press of the key moves one menu item forward (or back).
- Pressing the UP+DOWN (together) key confirms the selected menu item and enters the **Parameter** change mode for the selected menu item. To set a parameter see table **Parameter** on next page.
- Leave **Menu** mode by pressing M key again. If device remains in menu mode it still is OUT OF SERVICE and AUTOSTART has to be initiated. If the instrument is IN OPERATION, the display with the valve position appears. If a menu was selected and no further keys are pressed thereafter, the EP200 switches automatically back to operation after some minutes.

Menu structure for EP200

Main Menu

Menu / Display	Factory configuration	Description
1 Mounting		
1.1 Lin left	✓	Linear actuator, left-hand or direct mounting
1.2 Lin right		Linear actuator, right-hand mounting
1.3 Rot cclockw		Rotary actuator, opening counter-clockwise
1.4 Rot clockw		Rotary actuator, opening clockwise
2 Autostart		
2.1 Endpoints		Adaptation to the mechanical stops only
2.2 Standard		Autostart recommended for standard application
2.3 Enhanced		Optimized control behaviour compared to Standard Autostart
2.4 Smooth resp.		Extended Autostart, Dampened control behaviour for e.g. smaller actuators
2.5 Fast resp.		Extended Autostart, Undampened control behaviour for e.g. larger actuators
3 Valve Action		
3.1 Positioner		Action of Positioner:
3.1.1 Direct	✓	Valve opens with increasing setpoint value
3.1.2 Reverse		Valve closes with increasing setpoint value
3.2 Feedback		Action of Feedback unit:
3.2.1 Direct	✓	Increasing current with increasing valve position
3.2.2 Reverse		Decreasing current with increasing valve position
4 Character		
4.1 Linear	✓	Linear characteristic
4.2 Eq Perc 1:50		Equal percentage characteristic 1:50
4.3 Quick open		Inverse equal percentage characteristic 1:50 (quick opening)
4.4 Customer		Custom characteristic (configuration via DTM)
5 Limits/alarms		
5.1 Lower limit	0 %	Closing limit is set to input value
5.2 Cutoff low	1 %	0 %-tight sealing point is set to input value
5.3 Cutoff high	100 %	100 %-tight sealing point is set to input value
5.4 Upper limit	100 %	Opening limit is set to input value
5.5 Splitr 0 %	4 mA	Split range 0 % : input value corresponds to 0 %
5.6 Splitr 100 %	20 mA	Split range 100 %: input value corresponds to 100 %
5.7 Lower Alarm	-10 %	Lower position alarm on output 1 is set to input value
5.8 Upper Alarm	110 %	Upper position alarm on output 2 is set to input value
5.9 Valve 0%	4 mA	Configuration of rated-stroke of 0 % at 4 mA
5.10 Valve 100%	20 mA	Configuration of rated-stroke of 100% at 20 mA
5.11 Stroke Range	x° / 20mm	Configuration of nominal travel
5.12 Temp unit	°C	Configuration of the temperature unit °C or °F
6 Parameters		
6.1 Gain closing	15	P: Proportional gain for 'close valve'
6.2 Gain opening	2	p: Proportional gain for 'open valve'
6.3 Res time cl	7.5	I: Integration time for 'close valve'
6.4 Res time op	2.4	I: Integration time for 'open valve'
6.5 Rate lim cl	0.35	T63: Setting time for 'close valve'
6.6 Rate lim op	0.35	T63: Setting time for 'open valve'
6.7 Control gap	0.1	Permitted neutral zone for control difference
7 Output		Manual setting of IP-Module for testing of pneumatic output
8 Setpoint		Manual setting of valve position:
8.1 12.5% Steps		Setpoint changes of 12.5% steps by using push buttons Up or Down
8.2 1% Steps		Setpoint changes of 1 % steps by using push buttons Up or Down
8.3 Do PST		Starts the Partial Stroke Test, with the given parameters by DTM
9 Workbench		
9.1 Reset Config		Resetting of configuration to settings "ex factory"
9.2 Calib. 4 mA		Calibrate input current to 4 mA
9.3 Calib. 20 mA		Calibrate input current to 20 mA
9.4 Calib. -45°		Calibrate position measuring value to -45°
9.5 Calib. +45°		Calibrate position measuring value to +45°
9.6 Reset all 1	✓	Resetting of configuration and Calibration (!) to "ex factory" settings for single-acting output
9.7 Reset all 2		Resetting of configuration and Calibration (!) to "ex factory" settings for double-acting output
9.8 Go online		Service function: Start of controller without Autostart. Not recommended for regular use
9.9 Menu Lang		Language on LCD:
9.9.1 English	✓	Standard English
9.9.2 Deutsch		Standard German
9.9.3 Français		Preselected / freely definable third language
9.10 LCD orient		Orientation of LCD:
9.10.1 Normal		Normal orientation of writing on LCD
9.10.2 Flipped		Reverse orientation of writing on LCD
9.11 Cal. Feedbk		Calibration of output current of position transmitter:
9.11.1 Cal 4mA		Calibration of the 0 % at 4mA
9.11.2 Cal. 20mA		Calibration of the 100 % at 20mA
10 not used		

Additional Parameters

The following parameters are accessible via communication only:

Parameter	ex factory
Control difference limit value	5 %
Control difference response time	1 min
Sealing hysteresis	0.5 %
Failsafe-Aktion	OFF
Power-up action	IN SERVICE
Parameter write protection	OFF
Alarm limit for total strokes	90 Mio.
Alarm limit for total cycles	90 Mio.
Dead band for valve cycles	1 %
Set value source: Model Code xFxx	digital
Set value source: all others	analog
Upper pre-alarm	100 %
Lower pre-alarm	0 %
Hysteresis for position alarms	0.5 %

Complete parameter list see FDT/DTM Software.

**Configuration of 0 and 100 %
Rotary actuators**

Valid for single and double acting

Configuration requested					
MENU 1: "Mounting"				MENU 3: "Valve Action"	
1.1	1.2	1.3	1.4	3.1	3.2

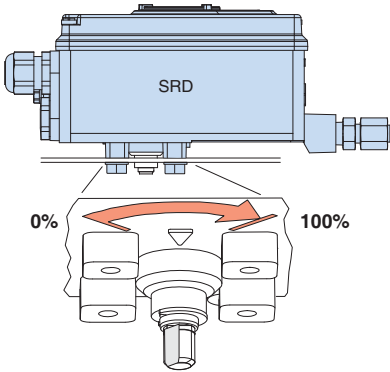
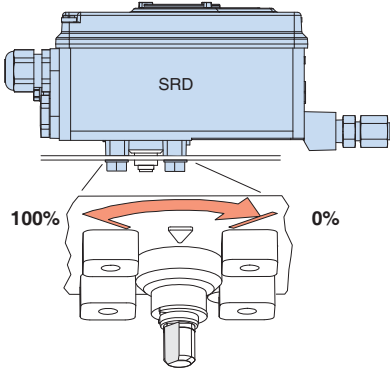
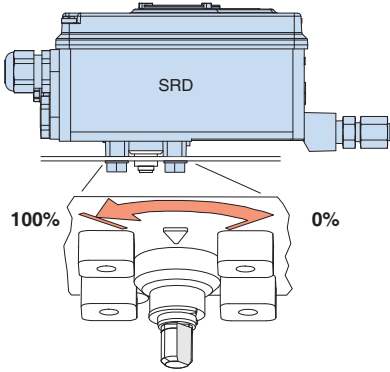
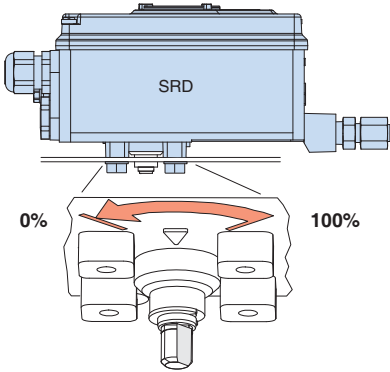
Configuration of 0 and 100%	Request Action	Linear Left	Linear Right	Rot cclockw	Rot clockwise	Direct	Reverse
	4 mA = 0% 20 mA = 100%			✓		✓	
	4 mA = 100% 20 mA = 0%			✓			✓
	4 mA = 0% 20 mA = 100%				✓	✓	
	4 mA = 100% 20 mA = 0%				✓		✓
	4 mA = 0% 20 mA = 100%				✓	✓	
	4 mA = 100% 20 mA = 0%				✓		✓
	4 mA = 0% 20 mA = 100%			✓		✓	
	4 mA = 100% 20 mA = 0%			✓			✓

8.4 Description of menus

Because of optimised local operation, for configuration neither PC nor control system is required.

In case operation via local keys is not possible
check if write protection is set.
Change via FDT/DTM software.

Menu 1: Actuator system, Mounting side

```
SRD Main Menu
1 Mounting
2 Autostart
3 Valve Action
```

Confirm with keys **UP+DOWN**

Start picture "Mounting side"; further with **UP** key

```
1 Mounting
1.1 Lin left
1.2 Lin right
1.3 Rot cclockw
```

```
1 Mounting
1.2 Lin right
1.3 Rot cclockw
1.4 Rot clockw
```

For an optimal actuator adaptation the EP200 has to be configured whether it is a rotary or a linear actuator.

The positioner of the **rotary** actuator can work directly with the linear position sensor value.

There are rotary actuator types opening in the counter clockwise direction and others opening in the clockwise direction. This also has to be signaled to the Positioner.

For rotary actuators opening the valve during **counter clockwise** (left) rotation.

For rotary actuators opening the valve during **clockwise** (right) rotation.

Menu 2: Autostart

```
SRD Main Menu
1 Mounting
2 Autostart
3 Valve Action
```

```
2 Autostart
2.1 Endpoints
2.2 Standard
2.3 Enhanced
```

```
2 Autostart
2.3 Enhanced
2.4 Smooth resp.
2.5 Fast resp.
```

```
2 Autostart
SRD991 Vers.xx
Get end points
```

```
2 Autostart
SRD991 Vers.xx
Get motor gain
```

```
2 Autostart
SRD991 Vers.xx
Control params
```

```
2 Autostart
SRD991 Vers.xx
Get valve speed
```

Selection between different Autostart modes (change with key UP or DOWN):

Autostart:

To automatically adapt the positioner to the valve. Geometric data of the actuator is determined and optimally assigned to control parameters. If the "Standard" Autostart does not result in stable regulation, another Autostart mode - depending upon actuator - should be selected. At **initial start-up**, an Autostart should always be performed.

Attention: Autostart overwrites previous control parameters!

2.2 Ready for "**Standard**" Autostart:

With key UP or DOWN to other Autostart modes:

2.1 Ready for "**End points**" Autostart:

Serves for automatic adjustment of the EP200 to the mechanical end points

2.3 Ready for "**Enhanced**" Autostart:

To the optimization of the controller parameters in relation to standard mode

2.4 Ready for "**Smooth response**" Autostart:

Extended, damped controller parameters for e.g. smaller drives

2.5 Ready for "**Fast response**" Autostart:

Extended, undamped controller parameters for e.g. larger drives

After selection and start (by pressing the UP+DOWN keys) the function can be followed at LCD.

Duration on a valve position can take some time depending on actuator volume, air supply, pressure, etc.

Moving direction, mechanical starting and ending positions are determined by one or several passages of valve position range.

Ramps are entered and control system parameter is determined (ratio position / valve size).

Jumps are entered for determination of control parameters.

Determination of positioning speeds.

Determined values are saved; previous values are superscribed. The EP200 is IN SERVICE again with the detected new parameters.

Menu 3: Mode of Action

```
SRD Main Menu
1 Mounting
2 Autostart
3 Valve Action
```

```
3.1 SRD
3.1.1 Direct
3.1.2 Reverse
```

Function of the positioner is set at:

3.1.1 "Normal" if increasing input signal is to initiate increasing output signal.

3.1.2 "Reverse" if increasing input signal is to initiate decreasing output signal.

Menu 4: Characteristic of setpoint

```
SRD Main Menu
2 Autostart
3 Valve Action
4 Valve Char.
```

```
4 Valve Char.
4.1 Linear
4.2 Eq Perc 1:50
4.3 Quick open
```

A relationship between the input signal and valve position is set.

4.1 "Linear". See Fig.

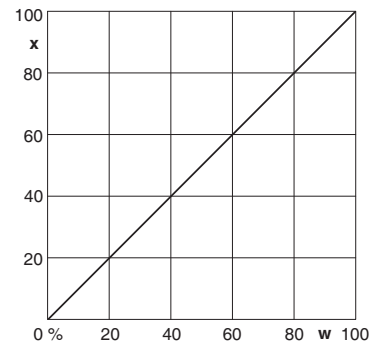

```
4 Valve Char.
4.1 Linear
4.2 Eq Perc 1:50
4.3 Quick open
```

4.2 "Equal percentage": Results in an equal percentage characteristic line with a position ratio of 1:50 for a valve of linear characteristic.

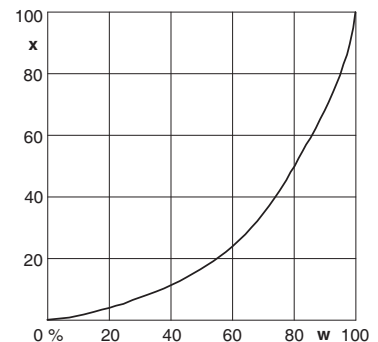

```
4 Valve Char.
4.1 Linear
4.2 Eq Perc 1:50
4.3 Quick open
```

4.3 "Inverse equal perc.": Results in an inversely equal percentage characteristic line with a position ratio of 50:1 for a valve of linear characteristic.

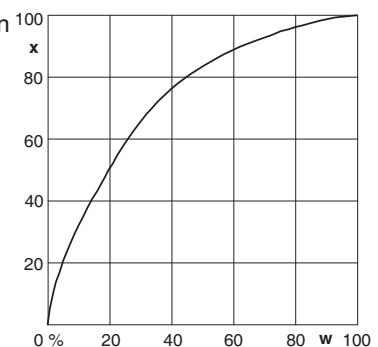

```

4 Valve Char.
4.2 Eq Perc 1:50
4.3 Quick open
4.4 Custom
    
```

```

- - - - 1 LED 4 lights up
    
```

“User defined characteristic”:
 A characteristic line entered via communication (not via local keys) with 2 to 22 supporting points) is activated.
 A linear characteristic is factory set.

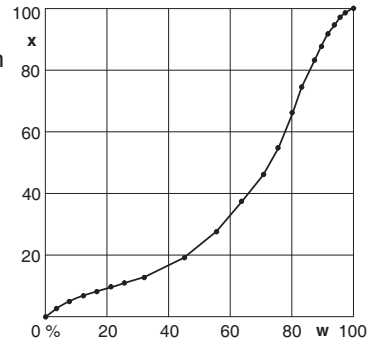

Menu 5: Limit and Alarms of valve

```

SRD Main Menu
3 Valve Action
4 Valve Char.
5 Limits/Alarms
    
```

Note:

With versions with LCD, the values for Limits and Alarms can be adjusted stepwise locally in “clear text” with keys UP or DOWN.
 With versions with LED and HART or “without communication”, the corresponding current of the valve is rated via analog output and entered with keys UP+DOWN.
 With versions with communication, the values can be configured also with corresponding software.

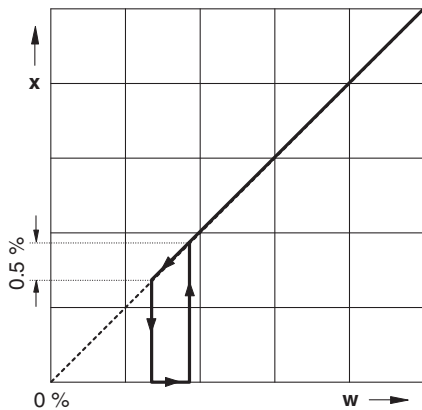

Sealing tightly, linear characteristic line

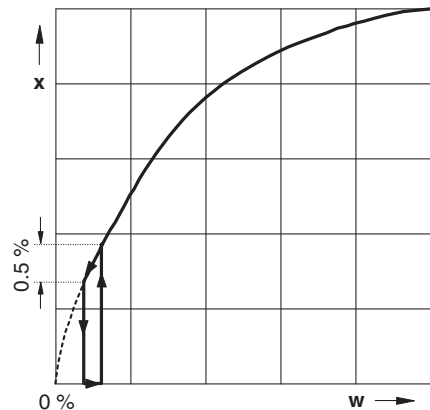

Sealing tightly, inversely equal percentage

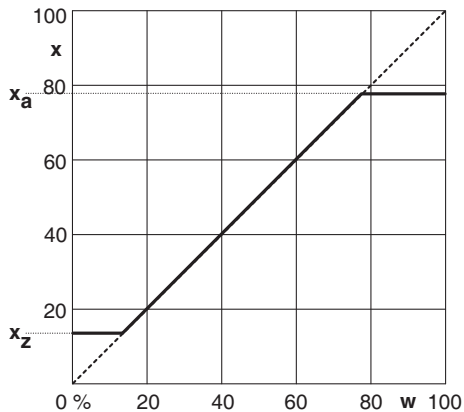

Opening limit x_a , Closing limit x_z , linear characteristic

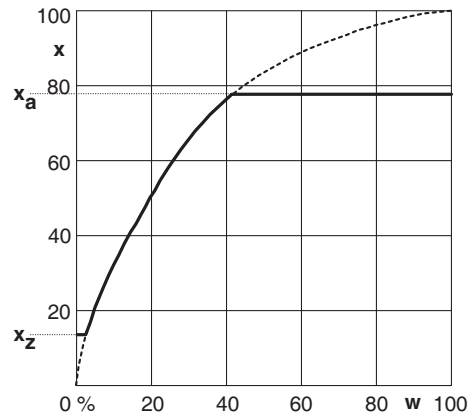

Opening limit x_a , Closing limit x_z , inversely equal percentage characteristic

```
5 Limits/Alarms
5.1 Lower limit
5.2 Cutoff low
5.3 Cutoff high
```

```
5.1 Lower limit
2.0 %
```

```
5 Limits/Alarms
5.1 Lower limit
5.2 Cutoff low
5.3 Cutoff high
```

```
5.2 Cutoff low
3.0 %
```

```
5 Limits/Alarms
5.1 Lower limit
5.2 Cutoff low
5.3 Cutoff high
```

```
5.3 Cutoff high
97.0 %
```

```
5 Limits/Alarms
5.2 Cutoff low
5.3 Cutoff high
5.4 Upper limit
```

5.1 Setting Lower limit ("closing limit")

The positioner provides that IN SERVICE the valve position does not close any further than defined by the closing limit. If the setpoint value is lower than this limit, message 12 is produced.

By pressing of UP or DOWN keys, the value is adjusted and confirmed with keys UP+DOWN. The keys have Autorepeat: By pressing and holding of a key UP or DOWN, the value is counted upward, after some time in larger steps.

Example: Lower limit is set to 2 %.

5.2 Setting Cutoff low ("0% seal-tight point")

If a 0% seal-tight point is given, in case the setpoint is deviated lower (e.g. 3 %), the EP200 provides the pneumatic output to press the valve into its seat with full force in order to tightly seal valve.

As soon as the command value is 1%* higher than this seal-tight value, the position again follows the command value.

* This ist the "Seal-tight hysteresis", factory set at 1 %. The value may be changed via communication.

5.3 Setting Cutoff high ("100% seal-tight point")

If a 100% seal-tight point is pre-set and in case a certain set value is exceeded (e.g. 97 %), the EP200 provides that the pneumatic output presses the valve 100 % into its seat with full force.

This function makes sense for 3-way valves.

Also both seal-tight points can be used in order to tightly close the respective shut-off path during partial operation.

By pressing of UP or DOWN keys, the value is adjusted and confirmed with keys UP+DOWN. The keys have Autorepeat: By pressing and holding of a key UP or DOWN, the value is counted upward, after some time in larger steps.

Example: Cutoff high is set to 97 %.

5.4 Setting Upper limit ("opening limit")

The EP200 provides that IN SERVICE the valve position does not open any further than defined by the opening limit. If the set value is exceeded, message 13 is produced.

Definitions

Stroke, stroke range of the membrane actuator is defined for rotary actuator as **angle, angle range**.

0 % position is the mechanical impact at actually closed valve (caution if using handwheel and mechanically adjustable stroke limitation!)

100 % position is the mechanical impact at actually open valve.

Closing limit is a lower limit set via software. In normal operation the valve will not close more than set here. Attention: In the event of failure of the auxiliary energy no controlling is possible, therefore the springs in the actuator will move the valve into safety position (for single-acting actuator).

Opening limit is a upper limit set via software. In normal operation the valve will not close more than set here. Attention: In the event of failure of the auxiliary energy no controlling is possible, therefore the springs in the actuator will move the valve into safety position (for single-acting actuator).

Normal operation (= IN SERVICE) means that the position is controlled to the 4–20 mA input signal.

Split Range

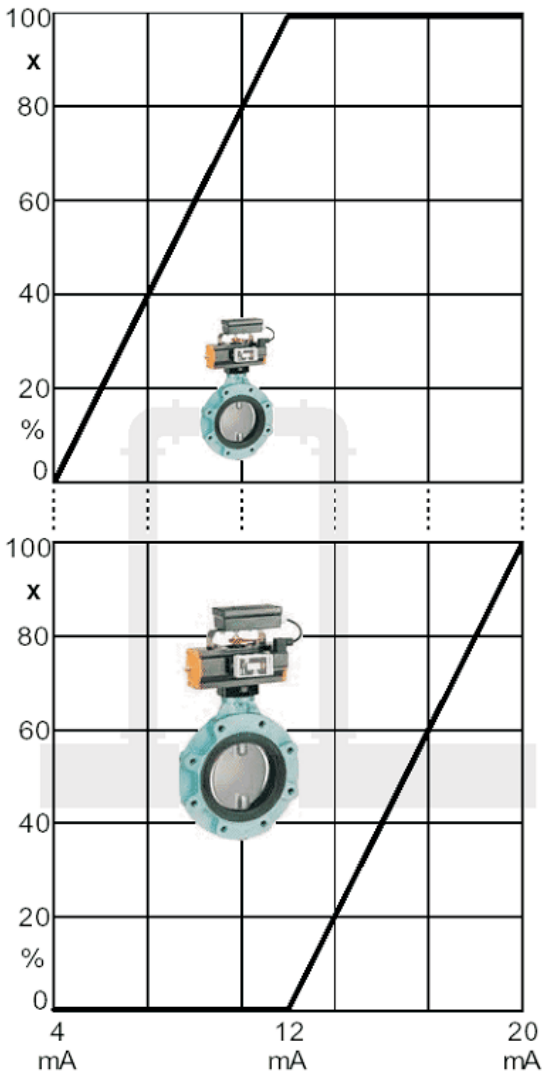

Split Range is useful if an additional control range is demanded which cannot be covered by one valve only. A valve of smaller nominal size can be applied overtaking the smallest quantities; a parallel mounted valve of bigger nominal size takes on the larger quantities.

With conventional positioners, this function is realized through serial connection of the instruments and allocation of individual regulating ranges (see illustration).

With EP200 with analog setpoint value, this can be adjusted with menus 5.5 and 5.6.

Example: At low current, only the smaller valve positions; from approx. 40 % the large valve is added

```

5 Limits/Alarms
5.4 Upper limit
5.5 Splitr 0 %
5.6 Splitr 100 %
    
```

5.5 Split Range 0 %

LCD: By pressing of keys UP or DOWN the value is adjusted and confirmed with keys UP+DOWN.

```

5 Limits/Alarms
5.4 Upper limit
5.5 Splitr 0 %
5.6 Splitr 100 %
    
```

5.6 Split Range 100 %

LCD: By pressing of keys UP or DOWN the value is adjusted and confirmed with keys UP+DOWN.

The keys have Autorepeat: By pressing and holding of a key UP or DOWN, the value is counted upward, after some time in larger steps.

```

5.6 Splitr 100 %
10.4 mA
    
```

Example: An input current of 10.4 mA has to correspond to a valve position of 100 %.

```
5 Limits/Alarms
5.6 Splitr 100 %
5.7 Lower Alarm
5.8 Upper Alarm
```

```
5 Limits/Alarms
5.6 Splitr 100 %
5.7 Lower Alarm
5.8 Upper Alarm
```

```
5.8 Upper Alarm
91.3 %
```

```
5 Limits/Alarms
5.9 Valve 0 %
5.10 Valve 100 %
5.11 Stroke
```

```
5 Limits/Alarms
5.9 Valve 0 %
5.10 Valve 100 %
5.11 Stroke
```

```
5.10 Valve 100 %
98.4 %
Confirm
```

```
5 Limits/Alarms
5.10 Valve 100 %
5.11 Stroke
5.12 Temp unit
```

```
5.11 Stroke
30.0 mm
1 in = 25.4 mm
```

```
5 Limits/Alarms
5.10 Valve 100 %
5.11 Stroke
5.12 Temp unit
```

5.7 Setting Lower Alarm

When falling below the set value underneath the entered alarm limit, an alarm is activated. Message 12 (see page 51) is generated. To switch off the alarm setting, enter the value -10%.

5.8 Setting Upper Alarm

When surpassing the set value above the entered alarm limit, an alarm is activated. Message 13 is generated. To switch off the alarm setting, enter the value +110%.

By pressing of keys UP or DOWN, the value is adjusted and with keys UP+DOWN confirmed. The keys have Autorepeat: By pressing and holding of a keyUP or DOWN, the value is counted upward, after some time in larger steps.

Example: Upper Alarm set to 91.3 %.

5.9 Valve Limits

At Autostart the EP200 determines the real limits of the actuator (which generally are a little larger then specified on the specification sheet). An actuator with 30 mm stroke, could display a real stroke of 33 mm. In order to produce a precise relationship between the input signal and the stroke, the tolerances of the actuator can be compensated with menus 5.9 and 5.10. At unchanged 0 %, the actuator could be moved until exactly 30 mm are reached. Through execution of function 5.10, the current position can be declared as 100 % and at a setpoint value of 50 %, the actuator will run on exactly 15 mm.

For new configuration of the strokes at 0% or 100%, the valve must be run in the corresponding position and then must be confirmed.

5.9 Setting Valve 0 %

The actual position of the actuator is declared as 0 %.

5.10 Setting Valve 100 %

The actual position of the actuator is declared as 100 %.

By pressing of keys UP or DOWN, the value is adjusted and with keys UP+DOWN confirmed. The keys have Autorepeat: By pressing and holding of a keyUP or DOWN, the value is counted upward, after some time in larger steps.

Example: The actual valve position 98.4 % is to be counted as 100 %.

5.11 Setting Stroke with stroke actuators

The EP200 measures with its feedback lever always only an angle and by means of its tangent function, a linear stroke of 0 to 100 % is calculated therefrom. In order to indicate as well a real stroke in mm, the full stroke at 100 % can be entered in this menu. The LCD display will then indicate the actual position in mm (or inch).

(Changing of display to "inch" via communication.)

By pressing of keys UP or DOWN, the value is adjusted and with keys UP+DOWN confirmed. The keys have Autorepeat: By pressing and holding of a keyUP or DOWN, the value is counted upward, after some time in larger steps.

Example: Stroke range of valve is to be 30 mm.

5.12 Temperature unit

Selection of temperature indication in °C or °F.

Menu 6: Parameter for Position controller

Along with the determination of the actuator geometry and control parameters the suitable setting parameters for the position controller are determined via function AUTO- START in Menu 2. Assessment of a control behavior generally is very subjective. Partially a quick response is requested without consideration of the overshoot width, partially a very smooth swinging is requested with minor overshoot.

We basically recommend to first perform the execution of the automatic setting via AUTOSTART in Menu 2 in order to achieve a stable control behavior. Corrections may then be made from the determined values. In rare cases AUTOSTART cannot find the optimal setting for the respective application. See "Remarks for controller optimization" following table 4.

A further optimization may follow by repeating AUTOSTART.

SRD Main Menu
4 Valve Char.
5 Limits/Alarms
6 Parameters

Seven control parameters are combined in Menu 6 each availing of a sub-menu. 15 different values may be selected in each of these and pressing of UP+DOWN be entered in the position controller as constant. Controller type is a PI controller.

Parameter-Designation	Valve is opening	Valve is closing	Unit
Proportionate amplification KP	P ↑	P ↓	-
Integration time constant	Tn ↑	Tn ↓	sec
Positioning time	T63 ↑	T63 ↓	sec
Dead band for control diff.	GAP	GAP	% of span

The dead band prevents (at the expense of accuracy) that the valve in the controlled condition constantly moves around the setpoint. This reduces harm to the mechanical parts of the actuator and, in particular, the valve packing.

6 Parameters
6.1 Gain closing
6.2 Gain opening
6.3 Res time cl

etc.

6 Parameters
6.4 Res time op
6.5 Rate lim cl
6.6 Rate lim op

6 Parameters
6.5 Rate lim cl
6.6 Rate lim op
6.7 Control gap

Selection of sub-menus:

Following selection of the sub-menu the codes for the parameter values (table 4) can be selected by pressing UP+DOWN:

Table 4: Allocation of the parameter values to coding:

Code	In LCD shown values: [in Menu Nr.]			
	P ↑ [6.2] P ↓ [6.1]	Tn ↑ [6.4] Tn ↓ [6.3] (sec)	T63 ↑ [6.6] T63 ↓ [6.5] (sec)	Dead band [6.7] (%)
1	2	1	0.1	0
2	2.66	1.33	0.15	0.12
3	3.50	1.75	0.25	0.16
4	4.7	2.4	0.35	0.22
5	6.3	3.2	0.5	0.3
6	8.4	4.2	0.75	0.4
7	11.2	5.6	1.15	0.53
8	15	7.5	1.75	0.7
9	20	10	2.6	0.94
10	26.6	13.3	3.9	1.25
11	35.5	17.8	5.9	1.67
12	47.3	23.7	8.85	2.22
13	63.1	31.6	13.3	2.96
14	84.2	42.1	20	3.95
15	112.2	- off -	30	5.3

Remarks to Controller Tuning

If AUTOSTART does not find the optimum setting the following may be the result:

- A) slow response to setpoint, long positioning time or long neutral time
- B) continuous oscillation following setpoint jump
- C) wide and high overshoot

For the assessment of the control 12.5 % jumps in both directions may be performed in Menu 8. The valve dynamics may be observed at LCD or the mechanical indicator.

Prior to changing parameters for valve dynamics a number of items are to be checked, see below. The pneumatic output can be operated directly without controller via Menu 7 and the valve movement may be assessed.

In case of behavior A) check:

1. Is the Proportionate gain P ↑ (Menu 6.1) or P ↓ (Menu 6.2) too small?
Remedy: Increase parameters according to Table 4.
2. Is the air pressure high enough to possibly overcome the actuator spring force and friction?
Remedy through increasing air pressure.
3. Is the actuator volume high, possibly requiring an increased air capacity for fast valve movement?
Remedy: through booster, see accessories, or spool valve option.

(Continued on next page)

4. Was AUTOSTART performed in Menu 2 and did messages 8 resp. 9 occur (messages, see table page 35)?
Remedy: "AUTOSTART" in Menu 2 resp. observe information in table, page 35.
5. Has the parameter for the positioning time been set at a value too high?
Remedy: decrease both parameters "T63" in Menu 6.5 or 6.6 .
6. Is valve packing too tight resulting in a very high friction?
7. Is the supply air filter blocked?
Remedy: Clean filter or exchange.
8. Has the supply air been contaminated by small oil drops, particulate or are pneumatic parts possibly blocked?
Remedy: exchange pneumatic parts; possibly use a suitable air supply station.

Behaviors B) and C) check:

1. Is the air capacity possibly too high, e.g. through spool valve or booster?
Remedy: Work, if necessary, without booster or use version without spool valve.
2. Has the air supply pressure been set too high?
Remedy: reduce pressure install pressure reducer.

Changing valve dynamics during behavior A):

If valve has a high friction (for example, often the case in small rotary actuators due to low air supply pressure or due to a valve seat packing which is too tight) then the valve position gets stuck after a setpoint jump and possibly is re-controlled via the resetting time T_n , possibly after quite some time has elapsed.

Basically, the following is possible:

- a) to accept a remaining deviation
- b) to accept some response procedures (such as remaining in over-response for a short time, and remaining below setpoint and trailing).

When deciding a), " T_n " should become ineffective, table value (15). Compensating " $P(kp)$ " should be increased until the setpoint jumps reach the setpoint within a short period of time and without significant over-response (adapt to both movement directions).

When deciding b) start as in a) above. Thereafter " T_n " is reswitched and decreased until the setpoint deviation has been re-controlled within a short period of time and without long after-response (adapt in both movement directions). It is recommended to maintain the T_n 's for both directions about the same.

If a post oscillation occurs after a setpoint jump, " T_n " is selected too small, possibly " $P(kp)$ " was selected too large.

The positioning time " $T63$ ", also called valve damping, does not have an effect during AUTOSTART in Menu 2, however, setpoint jumps in Menu 8 reach the position controller in a damped condition which then is not easily stimulated to oscillation. This behavior is also true for the setpoint input. This enables setting the controller to higher " $P(kp)$ " values without producing oscillations in the process. On one side this helps the position control to level disturbances due to friction, changes in load or air supply pressure changes faster. On the other hand it helps the superimposed valve control circuit that neutral times in the valve control route do not have such a big effect (stability in valve control circuit).

Changing valve dynamics during behavior B):

Increase " T_n " for both movement directions, possibly turn-off and proceed as described in behavior A) alternative b).

Menu 7: Pneumatic output (for trouble-shooting)

```
SRD Main Menu
5 Limits/Alarms
6 Parameters
7 Output
```

```
7 Output
□□□_____]
```

etc.

Serves to check the pneumatic parts of the positioner and the right valve piping by directly applying current to the IP module with the UP and DOWN keys (no control; software limit values such as "stroke limits" or "tight closing" are ignored).

The current of the IP module is increased by about 3% in 32 steps. By measuring the output pressure generally the following characteristic line of the IP module is achieved. The ramp also may be more steep or flat depending on the air supply pressure.

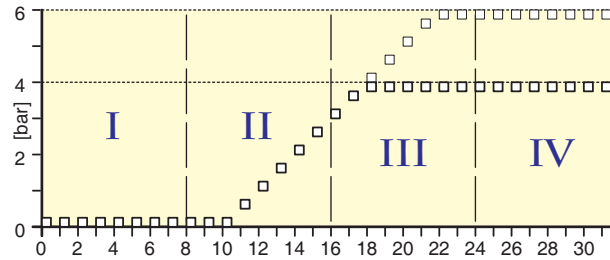

The pneumatic works precisely, if the actuator begins movement in section II and runs latest in section IV into the end position.

If no reaction is shown, check:

- does air supply exist? - is plug connected to IP module?

If these items are okay, possibly the electronics or a pneumatic part is defective.

After leaving this menu (by pressing the M key or UP+DOWN) the actual setpoint is automatically restarted.

Menu 8: Manual setting of valve position

```
SRD Main Menu
6 Parameters
7 Output
8 Setpoint
```

```
8 Setpoint
8.1 12.5% Steps
8.2 1% Steps
```

```
8 Setpoint
□_____] 12.5 %
Pos. 12.5 %
```

etc.

```
8 Setpoint
8.3 Do PST
8.1 12.5% Steps
8.2 1% Steps
```

For the purpose of checking the control reaction of the actuator to a setpoint jump can be observed via the indicator. As far as the device is IN SERVICE the UP/DOWN keys can initiate jumps of 12.5 % (or 1 %) each. The starting value for Menu 8 is always the current setpoint value.

If the control behavior is to be improved, this can be reached by performing a complete Autostart (see Menu 2) or through manual tuning (see Menu 6).

After leaving this menu the existing setpoint value at the input is automatically restarted.

This menu point can also be called up under normal operating conditions, by twice pressing of key M.

8.3 Do PST

With this function, the Partial Stroke Test is started, with the given parameters by DTM. If the test is passed back to the menu.

If the PST is not passed, the error message "PST error" appears on LCD.

Menu 9: Calibration functions (for workshop)

```
SRD Main Menu
7 Output
8 Setpoint
9 Workbench
```

```
9 Workbench
9.1 Reset Config
9.2 Calib 4 mA
9.3 Calib 20 mA
```

The following calibration functions must only be performed by trained personnel.

```
9 Workbench
9.1 Reset Config
9.2 Calib 4 mA
9.3 Calib 20 mA
```

```
9 Workbench
9.1 Reset Config
9.2 Calib 4 mA
9.3 Calib 20 mA
```

Factory calibrations are carried out with sufficient accuracy and remain unchanged during life time. However, an alignment may become necessary in some cases after servicing hardware components.

9.1 Reset Configuration to “ex factory” settings

It is possible to restore the configuration existing at time of delivery via this function. This may become necessary if it is unclear what had been changed per menu or in the event that a positioner was taken from one actuator and mounted to another actuator.

Following this function the device is turned to condition OUT OF SERVICE. This has to be followed by Autostart for the purpose of adapting the calibration to the actuator and to start IN SERVICE.

The parameters of the factory setting are listed in table “Menu Structure”.

The calibration of the input current or position sensor makes sense, if after exchange of the electronics, the valve position is inaccurately displayed.

Calibration of input current

Serves to equalize possible inaccuracies in the complete current loop.

9.2 Calibration of input current to 4 mA

The present input current value is taken over as “4 mA” when pressing keys UP+DOWN.

9.2 Calibration of input current to 20 mA

The present input current value is taken over as “20 mA” when pressing keys UP+DOWN.

```

9 Workbench
9.6 Reset all 1
9.7 Reset all 2
9.8 Go Online
    
```

```

9 Workbench
9.6 Reset all 1
9.7 Reset all 2
9.8 Go Online
    
```

```

9 Workbench
9.6 Reset all 1
9.7 Reset all 2
9.8 Go Online
    
```

```

9 Workbench
9.7 Reset all 2
9.8 Go Online
9.9 Menu Lang
    
```

```

9.9 Menu Lang
9.9.1 English
9.9.2 Deutsch
9.9.3 (Français)
    
```

```

9 Workbench
9.8 Go Online
9.9 Menu Lang
9.10 LCD Orient
    
```

```

9.10 LCD Orient
9.10.1 Normal
9.10.2 Flipped
    
```

```

9.10 LCD Orient
9.10.1 Normal
9.10.2 Flipped
    
```

```

9 Workbench
9.9 Menu Lang
9.10 LCD Orient
9.11 Cal feedbk
    
```

```

9.11 Cal feedbk
9.11.1 Cal 4mA
9.11.2 Cal 20mA
    
```

9.6 Resetting of Configuration and Calibration to “ex factory” settings

For the exchange of the electronics the device must be configured whether the pneumatic output is single-acting or double-acting so that the controller shows the correct behavior during the next start-up.

9.6 Resetting of Configuration and Calibration to “ex factory” settings – for single-acting pneumatic output

The factory calibration for single-acting pneumatic output is restored when pressing UP+DOWN keys simultaneously.

9.7 Resetting of Configuration and Calibration to “ex factory” settings – for double-acting output

The factory calibration for double-acting pneumatic output is restored when pressing UP+DOWN keys simultaneously.

9.8 Go Online without Autostart

In principle, the first startup runs an Autostart in which the EP200 is optimally adapted to the actuator, then the EP200 goes online and begins to regulate.

This service function sets the EP200 directly online, without an Autostart. Only for test purposes. Not recommended for regular use.

9.9 Selection of menu language

One of three of the programmed languages can be selected.

Ex-factory the active language is always English. Changing to one of the other two languages, can also take place during operation.

The third menu language can be selected and was already programmed in the factory according to customer order. If a different third menu language is desired, then the language file can be downloaded from the website:

<http://www.foxboro-eckardt.eu/download/PLFselector.html>

Thereafter download the file from the PC via FDT/DTM-Software onto the EP200.

9.10 LCD Orientation

Display normal or turned by 180°.

9.11 Calibration of Option "Position Feedback 4-20 mA"

Connect 24 V DC to the terminals of this option (see page 40) and insert a precise ampmeter into this loop.

Selecting "Cal. 4 mA" should result a current of 4 mA. Calibrate with keys UP or DOWN. Confirm with keys UP+DOWN.

Selecting "Cal. 20 mA" should result a current of 20 mA. Calibrate with keys UP or DOWN. Confirm with keys UP+DOWN.

8.5 Setting of the travel indicator

The mechanical travel indicator is coupled to the feedback shaft of the positioner by a gear. The gear has two selectable ratios¹⁾ 1 : 2 and 1 : 6.

Selecting gear ratio:

For rotation angles of the feedback shaft less than 30° select a ratio 1 : 6. This gear selection amplifies the feedback shaft rotation angle six times and for example, a 20° angle is shown as 120°.

For rotation angles greater than 30° select a ratio of 1 : 2. This gear selection amplifies the shaft rotation angle by a factor of two and for example, a 45° angle is shown as 90°.

For rotary actuators the rotation angle is equal to the rotation angle of the actuator. Consequently, a 90° rotation angle will result in a 180° display angle for the 1 : 2 gear ratio.

Setting gear ratio:

Remove the travel indicator **12**. Pull out the pin **12b** for a ratio 1 : 2 or push in the pin for a ratio 1 : 6. Use a smooth turning operation to free the gears and to set the pin **12b** against the stop. See illustration.

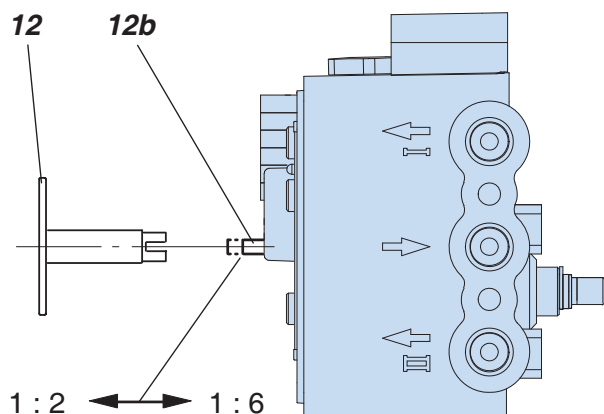

Turn the travel indicator **12** to the desired position, put it on the gear shaft against the stop and pinch the wire ring for secure coupling.

9 DECOMMISSIONING

Before decommissioning the unit, disconnect the supply air and the electrical input signal.

After disconnecting the electrical input signal the last confirmed configuration of the positioner is preserved in the memory.

Exchange of device

If a temporary decommissioning of the EP200 and a later mounting to another actuator has to be carried out, before disconnecting, we recommend to Reset Configuration in Menu 9.1. So the default settings "Ex-Factory" are re-activated. This facilitates a later recommissioning.

1) The values are rounded for making easier calculations.
The exact ratios are 1 : 1.83 and 1 : 6.28 .

10 SAFETY REQUIREMENTS

10.1 Accident prevention

This device complies with regulations for the prevention of accidents **Power-Driven Work Aids** (VGB 5) of 1st October 1985.

In option "limit switch" do not touch control vane during operation – danger of injuries!

10.2 Electrical safety

This instrument satisfies the conditions for safety class III, overvoltage category I according to EN 61010-1 or IEC1010-1.

Any work on electrical parts must be done by qualified personnel if any supply is connected to the instrument.

The instrument must be used for its designated purpose and connected in accordance with its connection diagram. Locally applicable installation regulations for electrical equipment must be observed, e.g. in the Federal Republic of Germany DIN VDE 0100 resp. DIN VDE 0800. The instrument contains no built-in fuses.

The instrument must be operated with safety extra low voltage SELV or SELV-E.

Safety precautions taken in the instrument may be rendered ineffectual if the instrument is not operated in accordance with the Master Instructions.

Limitation of power supplies for fire protection must be observed due to EN 61010-1, appendix F or IEC 1010-1.

10.3 EMC and CE

In order to ensure EMC protection, the black electronic cover made of conductive plastic has to be screwed to the housing.

10.4 Lightning protection

The isolation of the circuits to housing is tested up to 500 V AC.

The device is secured against energy discharges up to 1000 V sym / 2000 V asym.

From plant side, external lightning protection must be provided to ensure that these voltages are not exceeded.

11 TROUBLE-SHOOTING GUIDE

The components of the positioner are under constant surveillance by the installed micro controller. Detected errors are displayed in LCD.

Certain conditions (such as "Stroke limitation active") are displayed in LCD as message.

11.1 Errors detected during initialization

After start-up or reset several initialization phases are passed through which are shown in LCD. If this phase stops an error was detected.

If after renewed reset ¹⁾ the indicator stops at error code the device is probably defective and should be sent to the manufacturer for repair. Stating the error code will be helpful to the Repair and Service Dept.

LCD Error Codes in true text

Description
Micro controller functional test
Micro controller RAM test
Micro controller ROM test
initialize operating system
initialize monitor
initialize interfaces
initialize timer
initialize EEPROM
initialize data
initialize ADC
initialize communication
initialize local operation
start background process
check options and start
start operating system

11.2 Errors detected during self-test

During cyclical self-test certain components of the device are under constant surveillance. At trouble detection in the electronics, the display shows the error, and output y1 becomes pressureless ('fail safe position').

If after reset ¹⁾ the display shows the error again, the device is probably defective and should be sent to manufacturer for repair.

1) Execute reset by simultaneous pressing M+UP+DOWN keys, or by turn-off and restart of input signal

11.3 Messages

	Description of message / LCD text	Remedy
	Write protected	
Message 1: write protection	Parameter and functions are write-protected	Can be changed via Configurator, FDT/DTM Software
	Bad config CRC	
Message 2: Parameter	Invalid, undefined parameter values	Reset of configuration to factory setting in Menu 9.1
	Calib invalid	
Message 3: Calibration	Incomplete calibration or entering value resp. calibration value outside of permissible tolerance range	Repeat calibrations in Menus 9.2 ... 9.5
	Ill loop current	
Message 4: Input current outside of operating range	Check nameplate (INPUT) for correct version Message appears at input current under approx. 3.8 mA or above approx. 22 mA	check supply voltage, exchange EP200 if necessary
	Pot problem	
Message 5: Position sensor	Position sensor input recognizes error	check 3-pole plug at electronic board check cable to sensor check sensor (Potentiometer: 5k +20% -0%)
Positioner already calibrated, dismantled and supply. If you supply (4-20 mA or with a fieldbus) a positioner not mounted and bring the potentiometer out of range, the message will appear and remain till the potentiometer goes again in range and the error is validate with push button.	Position not within permissible rotation angle range. Lower deviation of the original 0% and exceeding of the original 100%, which have been determined by Autostart.	Check feedback lever mounting (flat area points to arrow on housing)
	During Autostart a change of the direction of movement was found	Acknowledge with UP+DOWN keys, then o.k.
		Check further possible reasons: valve seat worn-out; spindle lock out-of-line; carrier unit on spindle lock is damaged (for determination of valve position).
	IP motor problem	
Message 6: I/P-converter output	Connection I/P converter to electronic board faulty	check 2-pole plug at electronic board check cable to the I/P converter check I/P converter to detect short circuit or interruption
	No supply press	
Message 7: Air supply / pneumatic error	Detection: spring closes: w > 2 %, but position < 1 % spring opens: w < 98 %, but position > 99 % without spring: no actuator change in direction of position signal	check air supply pressure lead cable separated possibly poor control parameters are set pneumatic parts blocked

	Description of message / LCD text	Remedy
Autostart err 1		
Message 8: AUTOSTART defective	Air supply too low	Check air supply
	Feedback lever (linear actuator) or Coupling (rotary actuator) incorrectly linked. Potentiometer moves out of operating range of $\pm 47\%$ of 0° position	Check mounting. Flat area points to arrow on housing
	Coupling (rotary actuator) incorrectly linked (R and L interchanged)	Check mounting
	Pneumatic output to actuator closed or untight/ When direct mounting onto FlowTop or FlowPak, the screw plug y1-d is not removed.	Check pneumatic connections
	Mechanical stops not determinable	Check spring movement of actuator / check air supply / Check mounting
	When using a booster or spool valve, no control parameters can be determined, since air capacity is too high.	Device version is not suitable for this actuator; select version with smaller air capacity or remove booster.
	Control parameter too high since air capacity is too high (in general, oscillation in valve movement)	Use a booster or the version with spool valve. Reduce control parameter prop.-gain (Menu 6.1 and 6.2) to Code 10 = value 26.6.
Possibly incomprehensible configuration data	Reset configuration, see Menu 9.1	
Autostart err 2		
Message 9: AUTOSTART defective	Configuration to single-acting instead of double-acting actuator	Initialize factory calibration for double-acting in Menu 9.7
Optionboard err		
Message 10: Disturbances at Option board	Configured status of the EP200 deviates from existing version (e.g. Option board has been inserted subsequently).	Check if correct option board has been connected Confirm message and thereby new instrument version.
	Bad contact	Connections to terminals interchanged Check connections Tighten electronics
	Defective	Exchange option board
Ctrl diff error		
Message 11: Remaining control deviation	Actuator problems (high friction or blocked)	Check actuator
	Insufficient air supply	Check air supply / air filter
	Insufficient parameters for position controls, for example, amplification too small	Check control parameter, check pneumatic components
	IP module or pneumatic amplifier defect	Check in Menu 7; replace if necessary
Lower stroke lim		
Message 12: configured closing limit has been reached	If this is desired, the message may be ignored, of course.	If not, the setting has to be checked in Menu 5.1 or via communication
Upper stroke lim		
Message 13: configured opening limit has been reached	If this is desired, the message may be ignored, of course.	If not, the setting has to be checked in Menu 5.4 or via communication

	Description of message / LCD text	Remedy
Maintainance		
Message 14: Maintenance required	Operating point of controller is outside of permissible tolerance	Pneumatic components have to be checked and if necessary readjusted. Filters are possibly blocked and have to be replaced
Unforeseen		
Message 15:	Not defined	

Phase Diagram of Operating Modes EP200

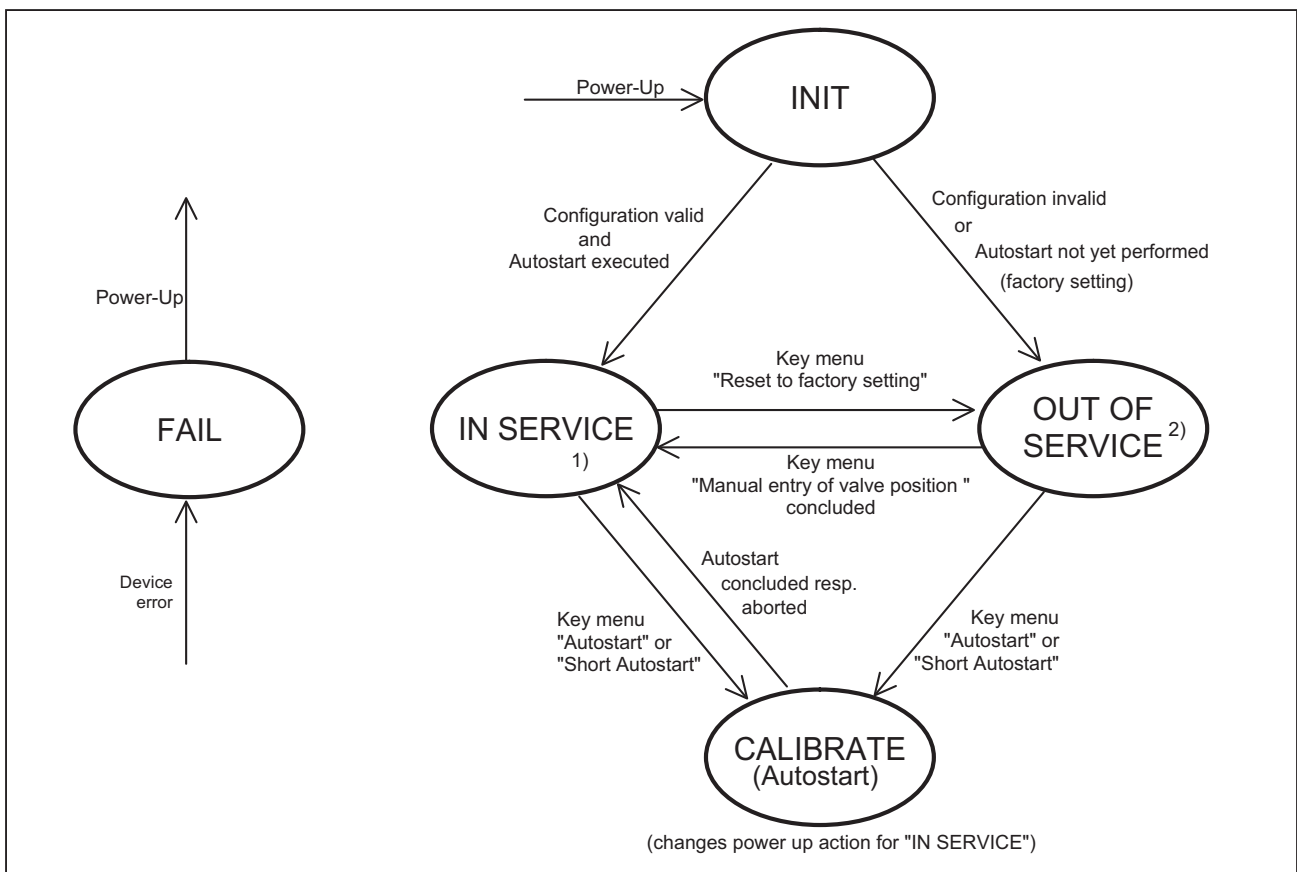

- 1) Menu indication may be turned on resp. off. Messages can be constantly shown.
- 2) Menu indication or message are constantly on

The respective oval shape indicates op-mode. Mode of operation changes in direction of arrow if described conditions are met.
 Key / menu "xxx" : Operation via local keys
 Power-Up: Return of the supply voltage or RESET

11.4 Diagnosis without LED or LCD inform

Fault	Possible cause	Solution
Positioner not operational using key pads	No input signal at 11, 12	Connect input signal
	Local operation blocked (write protection)	Remove blockage via communication
	No automatic power up (Reset)	Reset device with keys
	A key got jammed	Release cover screws, check menu functions, retighten cover
	Failure in the positioner	send device to manufacturer
Autostart not completed (> 45 min)	Actuator volume too large	stop Autostart and carry out extended Autostart, see chapter 8.4, Menü 2 or apply booster
	Failure in the positioner, otherwise Message 8, 9	carry out Autostart again, see chapter. 8.1 and 8.4, Menu 2 carry out Reset configuration send device to manufacturer
	Autostart remains stagnant for a longer time (>10 min) in step 1 or 2 (LED 1 or 2 lights up), otherwise message 8	Feedback lever (at stroke actuator) incorrectly mounted. Verify installation of feedback lever, see chapt. 4; flat part points to arrow on housing Coupling piece (at rotary actuator) incorrectly turned (R and L mixed up): Verify direction of rotation, see chapt. 4; flat part points to arrow on housing
	Autostart remains stagnant for a longer time (>10 min) in step 3 (LCD: shows "Control params")	At large volume actuators the Autostart can possibly remain stagnant for a longer time (>10 min) in step 3, prior to continuing in step 4
Actuator does not react to a change in the input signal	No Autostart performed.	Perform Autostart
	Positioner is not IN OPERATION	Switch positioner IN OPERATION, see chap. 8.2 resp. Autostart or via Configurator
	Setpoint source is configured wrong	Correct configuration via configurator
Actuator does not attain the closed or opened position	Autostart not carried out	carry out Autostart
	Supply pressure too low	check supply air pressure
	Travel limit is set Message 12, 13	check settings, see chapter 8.4, Menu 5
	Angle position linearization, positioner action or characteristic curve is set incorrectly (e.g. 'Custom', but values are missing)	check settings, see chapter 8.4, Menus 1, 3, 4
Unstable behavior, position control circuit oscillates	Autostart incomplete, therefore, control parameters not suitable	carry out complete Autostart, see chapter 8.4, Menu 2
	Small actuator volume but high air capacity	see chapter 8.4, Menu 6, reduce gain (P parameters)
	Friction on valve packing too great	loosen packing gland slightly or replace
	IP module or Pneumatic amplifier defective	change module, pneumatic amp
Actuator reacts too sluggishly	air capacity insufficient	attach booster
	gain set too low	see chapter 8.4, Menu 6
	positioning time T63 set too high	reduce positioning time, see chapter 8.4 Menu 6
No communication possible	Input voltage too low	Eliminate voltage drop
	Faulty protocol, communicator and device type do not match	Check configuration of devices
	Wrong electronics unit	change device

12 MAINTENANCE

12.1 General

The EP200 requires no periodical maintenance. When replacing components during repair work, the safety requirements must be observed!

12.2 Supply filter replacement

An obstructed supply filter can be replaced. Unscrew the air supply fitting, remove the filter and exchange the filter with a new one.

12.3 Removal of the electronics unit



WARNING

To avoid any personal injury resulting from bursting of parts, **take off air supply** before any removal of electronic board.

Pull off the travel indicator **12**. To remove the electronics unit **40**, loosen the 7 screws on the front.

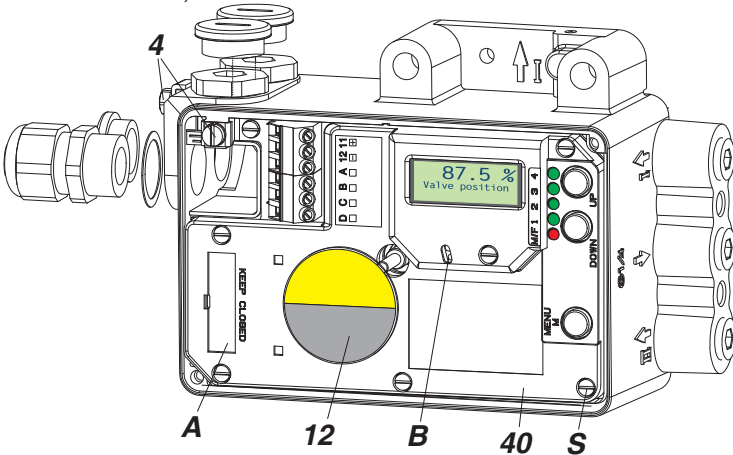

Lift the electronic vertically upward. Disconnect the plugs **41** and **42** (see illustration) from the board. Do not use tools to remove plugs, because components could be damaged. Tight-fitting plugs can be easily removed by tilting them diagonally inward before pulling them off.

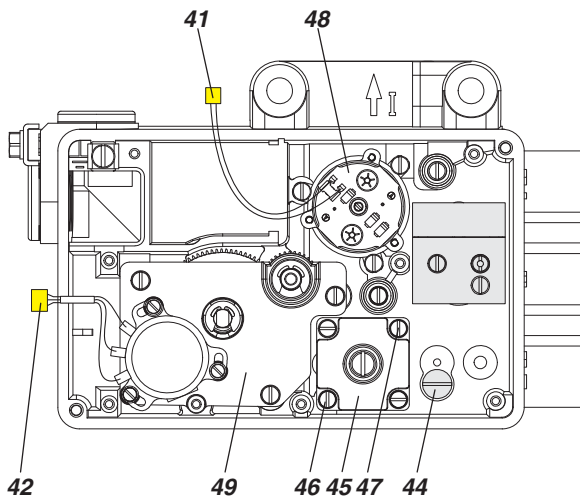

Connect the plugs **41** and **42** to the new electronics unit **40** and attach the new unit by using the 7 screws on the front (attention with the cables).

12.4 Replacement of mechanical and pneumatic units

First remove the electronics unit **40**. After the exchange always Autostart has to follow.

The exchange like also the change of preamplifier, amplifier, IP module and position feedback unit with potentiometer may be accomplished only by qualified personnel or by one of our service partners. The inappropriate exchange or a wrong calibration of the pneumatics components can lead to the fact that a correct regulation of the position control no more cannot be placed to safe. We recommend to exchange the entire unit against an exchange unit.

12.4.1 Amplifier replacement

Unscrew the pneumatic amplifier **43** from the base plate. Screw on new amplifier. Replace the O-rings between the amplifier and base plate. Use 3 O-rings for a single-acting amplifier and 5 O-rings for a double-acting amplifier.

12.4.3 Preamplifier replacement

Unscrew the preamplifier **45** from the base plate by removing screws **46** and **47**. Replace the 4 O-rings between preamplifier **45** and the base plate and install the new preamplifier.

12.4.4 IP module replacement

Unscrew the IP module **48** from the base plate and replace with a new IP module. Replace the O-ring between the IP module and the base plate and install the new IP module.

13 OPTIONS

13.1 "Limit switch"



WARNING

To avoid any personal injury do not touch control vanes during operation.

Remove three screws **A** including tooth lock washer from plastic cover.

Attach limit indicator **B** so that the flattened shaft end **19** contacts the groove of the limit indicator shaft in the positioner.

Attach limit indicator by means of three longer screws **C** and washers.

Test: the coupling shaft at back of positioner should easily be turnable, thereby also moving the vanes of the limit indicator. If this is not the case, loosen screws **C** and flush-align the shafts of positioner and limit switch (turn coupling shaft several times).

Replace short travel indicator **12** by long travel indicator.

Screw high cover **28** (or standard cover with insert frame) on housing.

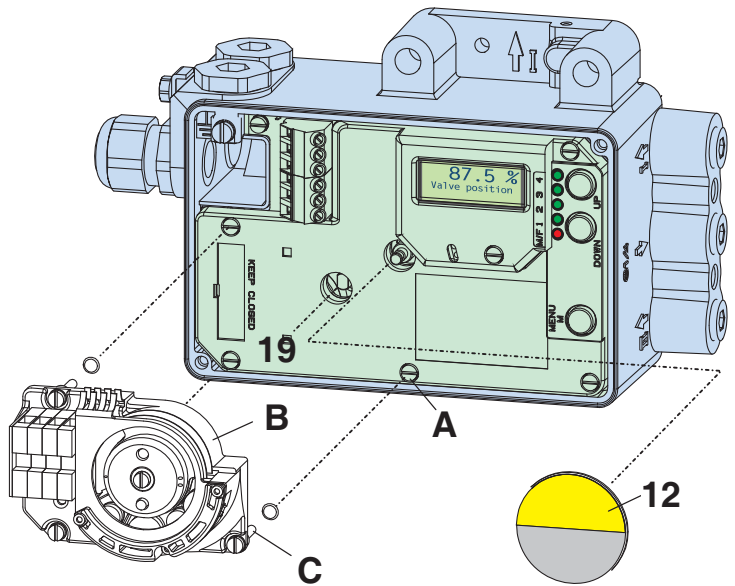

Switch functions

Feedback lever, feedback shaft and the control vanes are all connected to each other, without an intermediate transmission. The control vanes are therefore moving simultaneously with the same angle rate as the feedback lever. The length of the control vane corresponds with the swing angle of 120°.

Both control vanes are located on different planes. Each control vane can be seen independently from the other, because each has its own sensor.

By adjusting the screws, the control vanes can be adjusted relatively to the angle rate, so that e.g. one vane dives into and another dives out of the sensor (see illustration).

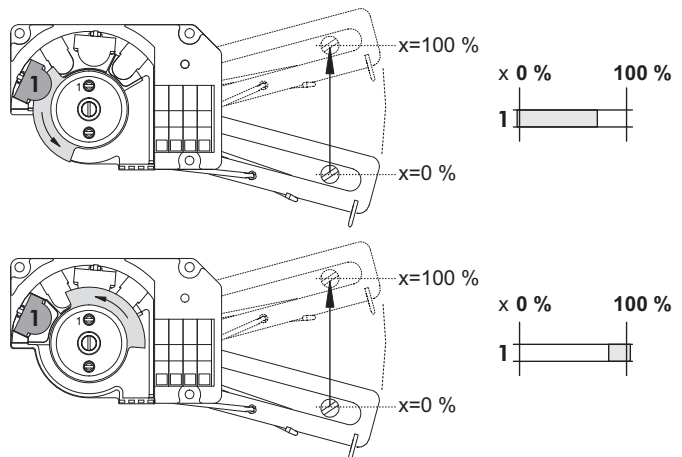

Setting limit switch trigger points

First loosen screw **S** until disc **D** is no longer blocked by bolt **B**. Then turn disc by 90°, until set screws **1** and **2** are accessible.

Set trigger point switch GW1:

Turn screw **1** at mark (•), until desired switch behavior is reached.

Set trigger point switch GW2:

Turn screw **2** at mark (••), until desired switch behavior is reached.

To fix switch points turn disc again by 90°, until the bolt catches, then fasten tight the center screw **S**.

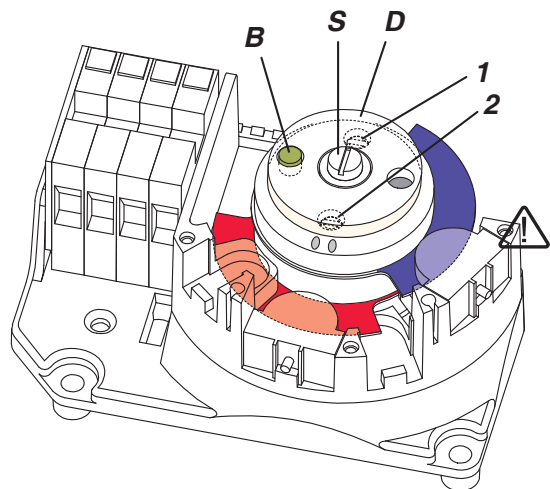

Levels of control vanes (illustration without cover)

13.2 Additional Inputs / Outputs

Option “Position feedback and alarm”

The **analog** output for **position feedback** indicates the valve position 0 to 100 % as current signal 4 to 20 mA. Signal range is 3.8 to 20.5 mA, at fault approx. 0.5 mA.

The **binary** output for **Alarm** will be activated in the following cases:

- Calibration error
(for example due to break-up of calibration) Message 3
- Output outside of limits determined during Autostart
(Check mounting of feedback lever) Message 5
- Circuit to potentiometer is disturbed
(cable plugged?) Message 5
- Circuit to IP module is disturbed
(cable plugged?) Message 6
- No actuator movement; Message 7
- Remaining control deviation (packing is too tight?)
Message 11

Signal range: 1 mA resp. 4...6 mA, at fault < 50 μ A.

In the event of disturbances in the electronics of the EP200 the Watchdog circuit is activated. The binary output for alarm signalizes this as “cable failure”.

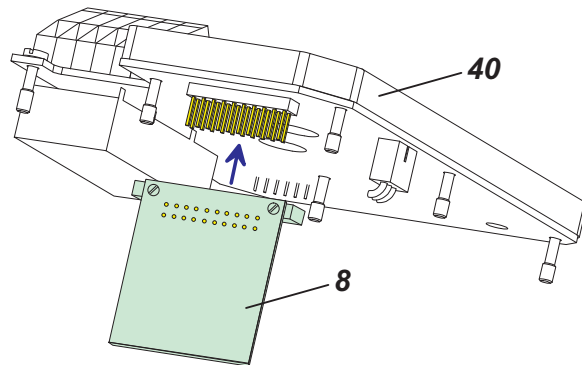

14 DIMENSIONS

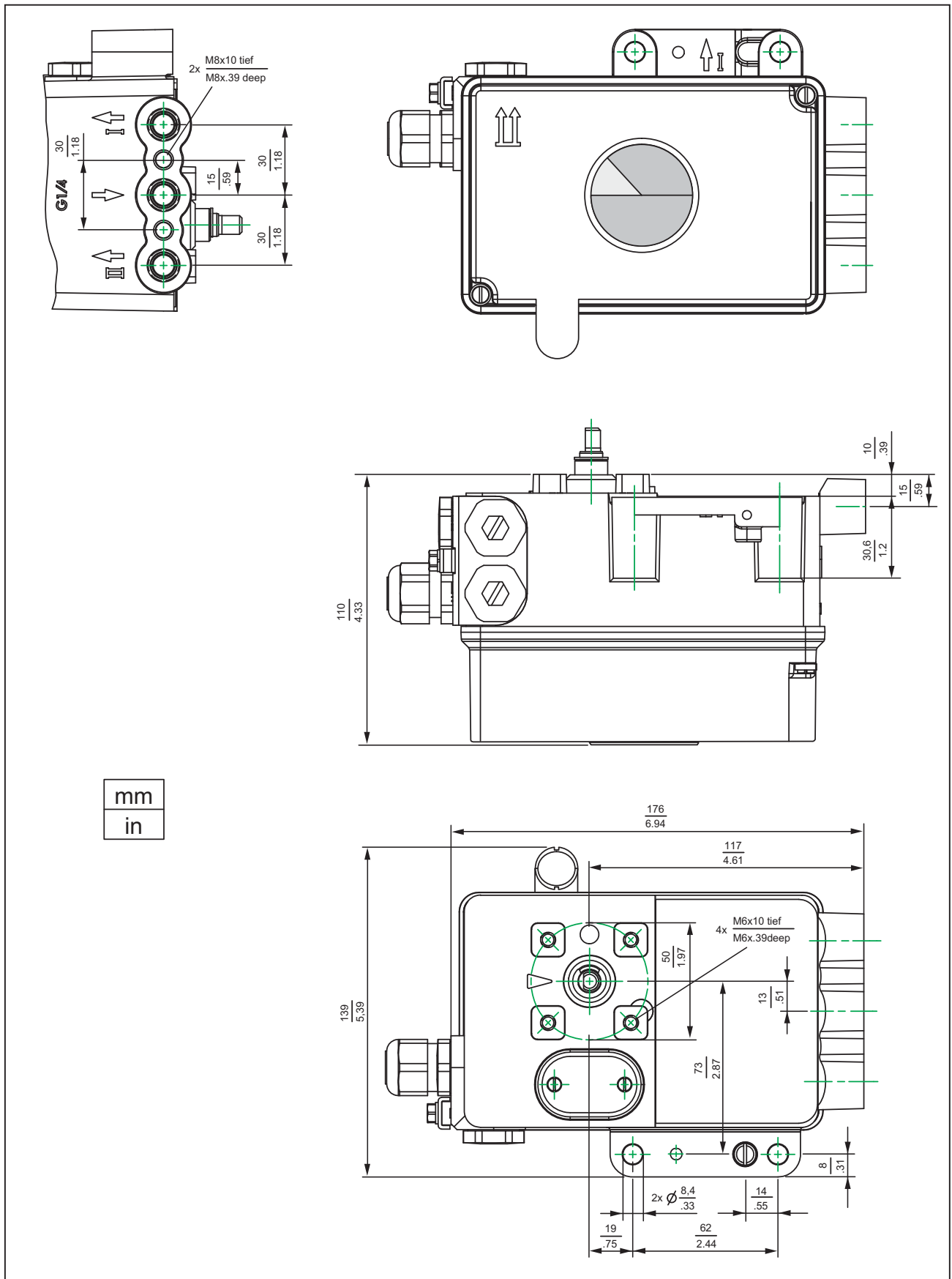

mm
in

ORDER CODES

Digital Positioner	EP200-				
Version					
Single Acting		E			
Double Acting		D			
Analog Position Feedback					
without			0		
Signal Output 4...20 mA			F		
Built-In Limit Switch					
without				S-	
Inductive Limit Switch - Intrinsic Safe (Standard Version)				T-	
Inductive Limit Switch - Intrinsic Safe (Security Version)				U-	
Inductive Limit Switch - Three Wire Version				R-	
Electrical Classification					
without					ZZZ

Subject to alterations - reprinting, copying and translation prohibited. Products and publications are normally quoted here without reference to existing patents, registered utility models or trademarks. The lack of any such reference does not justify the assumption that a product or symbol is free.

EBRO ARMATUREN, Gebr. Bröer GmbH
 Karlstrasse 8
 D-58135 Hagen • Germany
 Tel.: +49 (0)2331/904-0 www.ebro-armaturen.com
 Fax: +49 (0)2331/904-111 post@ebro-armaturen.com

Version 10.2012