

QUALITY FEATURES

PNEUMATIC ACTUATORS

SPRING UNITS

Single-acting actuators are equipped with two spring cups, so that the actuator can clearly be recognised as single-acting. Six different spring units are available, depending on the actuator size. The springs are prestressed, allowing the spring units to be replaced safely and easily.

PISTON GUIDE

Sliding pads and piston rings made of UHMWPE ensure low-friction piston guidance and prevent metallic contact between piston and cylinder.

CYLINDER

The piston bearing surface of the cylinder tube is precisely machined and anodised. The result: good wear resistance and consistently high efficiency in continuous operation.

SHAFT BEARING

The multiple shaft bearing reduces friction losses to a minimum and guarantees high efficiency.

SCOTCH YOKE CONCEPT

The structurally-dependent lever action is optimally matched to the torque curve.

NAMUR CONNECTION BLOCK

The NAMUR connection block can be rotated by 180° in order to change the function of the solenoid valve from "Normally closed" to "Normally open".

CORROSION-RESISTANT SCREW CONNECTIONS

All screw connections are stainless steel, thus guaranteeing corrosion protection and safe connection even with aggressive recirculating air.

PINNED DOUBLE YOKE

The pinned fitting of the double yoke guarantees backlash-free force transmission and protects the shaft from blow-out.

ADJUSTABLE LIMIT STOPS

The piston limit stop can be adjusted very precisely within a range of $\pm 3^\circ$.

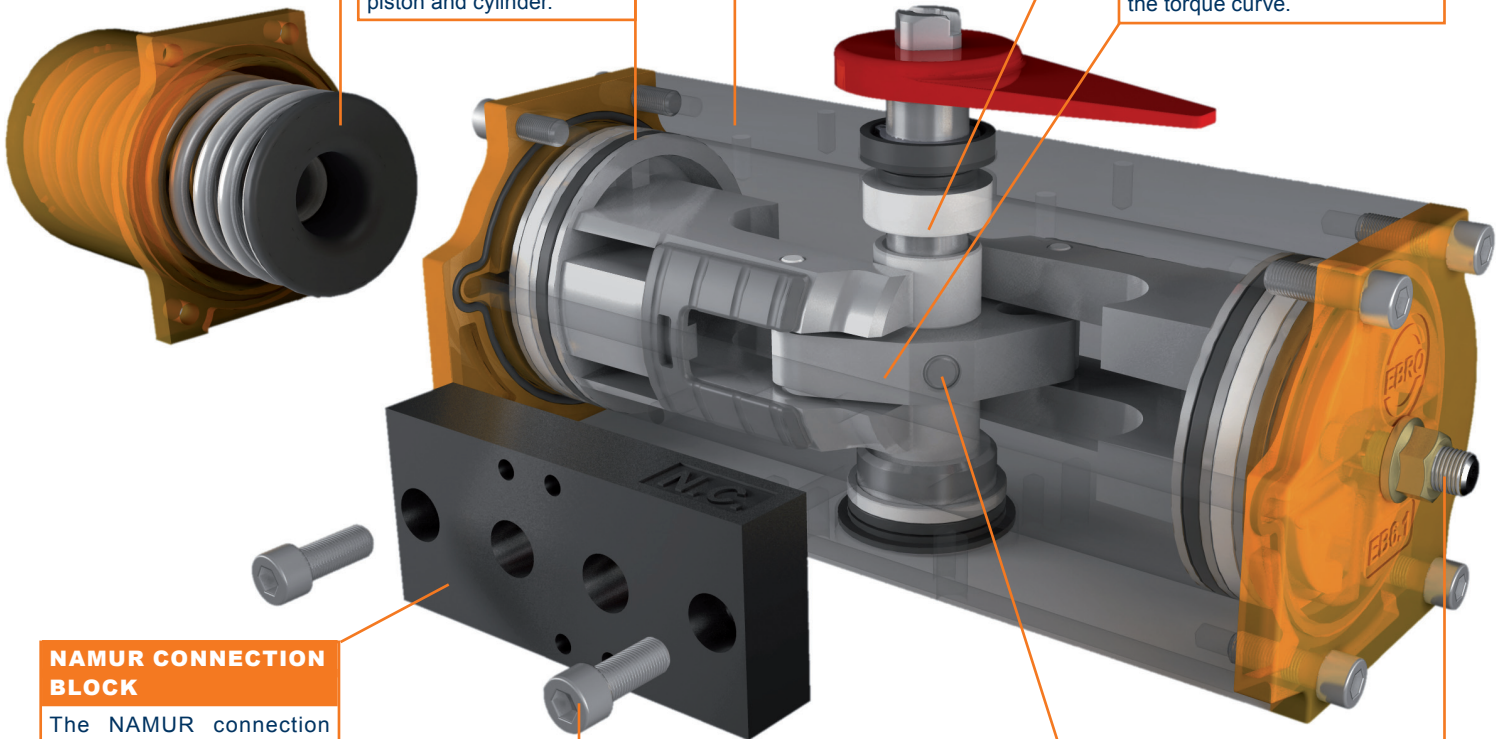

MADE BY



EBRO